

AMY QUEEN BED ASSEMBLY INSTRUCTIONS

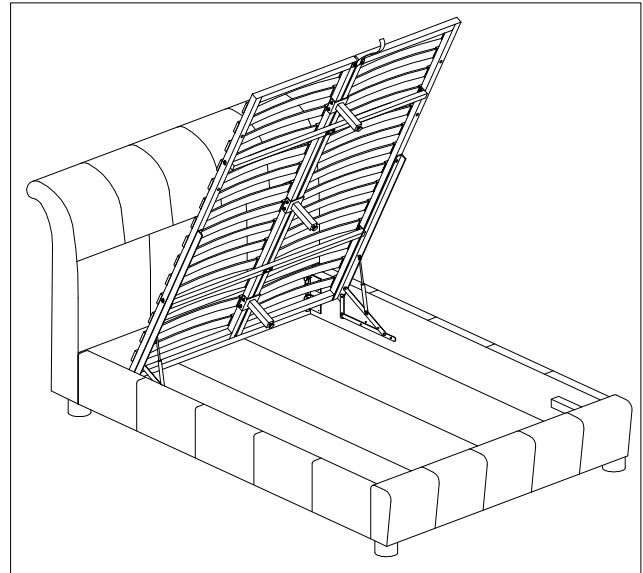
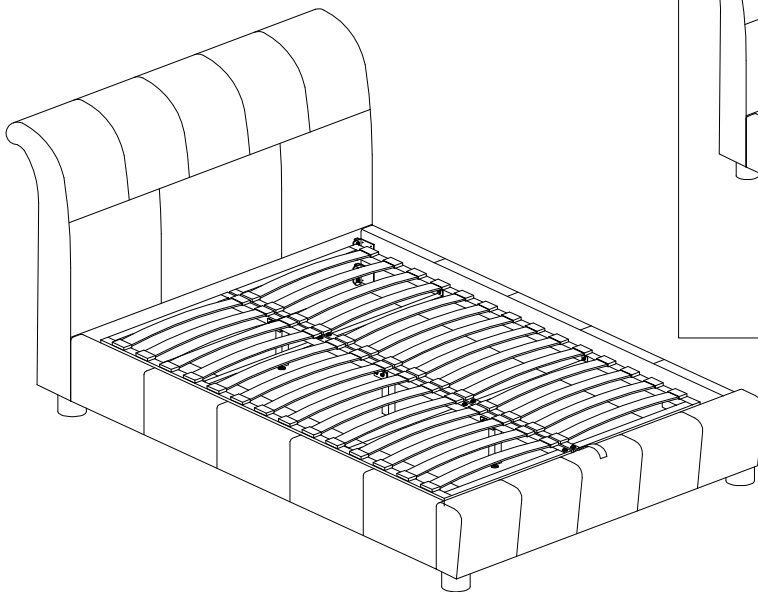

HELPFUL ADVICE PRIOR TO ASSEMBLING THE OTTOMAN BEDS

1. Owing to the size and the weight of the ottoman, we recommend that it is assembled on a flat surface in the room it is intended for and by two adults.
2. The product you have purchased will give you many years of service if you follow the guidelines for its safe assembly, periodic maintenance and cleaning. Special attention should be paid to moving parts such as hydraulic cylinders, which may need cleaning with a paper towel or similar material from time to time.
3. Please do not use any tools other than those provided or recommended in the assembly instructions. Use of a power tool will invalidate any claim and could make the product unsafe.
4. Please do not discard any packaging until you have checked that you have all the parts and fixings. Discard any excess fixings and keep all fittings out of reach of children.
5. The lift up action may be a little stiff at first but will ease after usage.
6. Assemble all parts loosely until advised to tighten. Depending on usage, it may be necessary to tighten the fixing from time to time.
7. Once the bed is fully assembled and before lowering the metal frame (with mattress in position), please ensure that the side rails and metal frame are correctly aligned and DO NOT touch, as leather may be damaged.

WARNING

1. PLEASE ENSURE CHILDREN DO NOT PLAY IN THE STORAGE AREA OR TRY TO LIFT UP THE METAL FRAME.
2. ONCE ASSEMBLED, PUT MATTRESS ON FRAME BEFORE PUSHING IT DOWN AND ONLY LIFT UP OR PUSH DOWN THE METAL FRAME WITH MATTRESS ON TOP.
3. PLEASE DO NOT STAND ON THE STORAGE BASE BOARDS AT ANY TIME.

PART LIST

(1) Headboard x 1 set

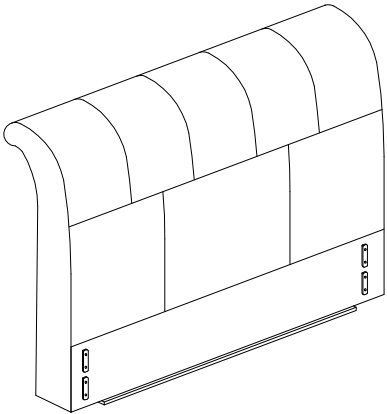

(2) Footboard x 1 set

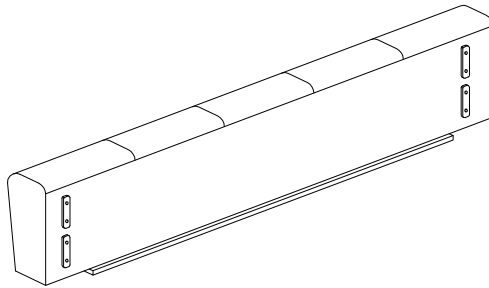

(3) Side rail x 2 pcs

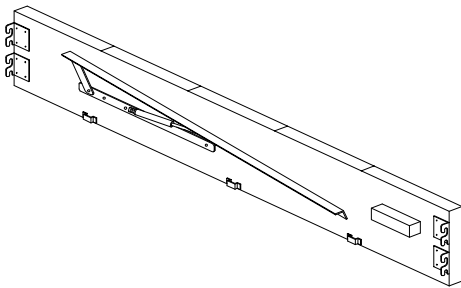

(4) Metal frame x 1 set

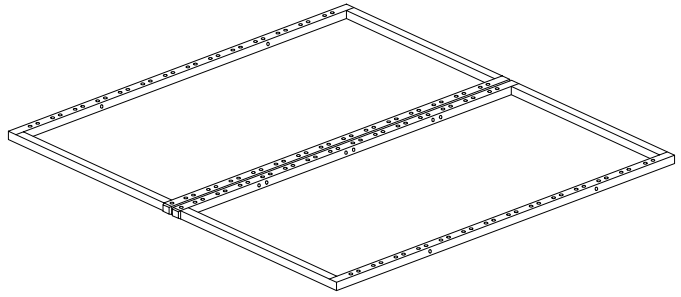

(5) Wooden horizontal support x 3 pcs

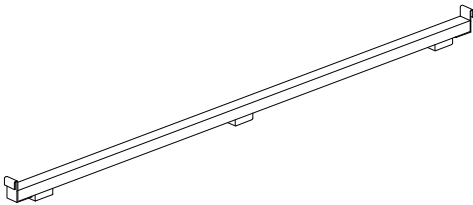

(6) Metal horizontal support x 2 pcs

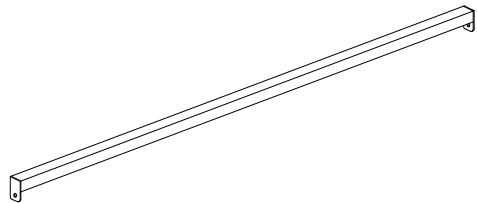

(7) Board x 3 pcs

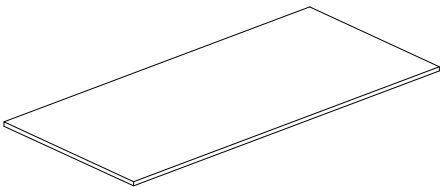

(8) Metal support leg x 3 pcs

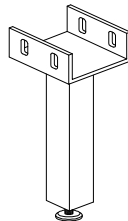

(9) Bent slat x 28 pcs

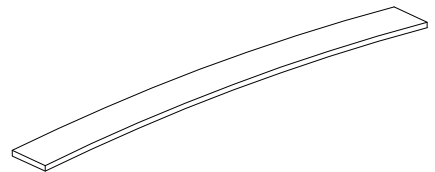

(10) Feet x 4 pcs

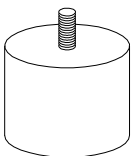

(11) Plastic cap x 56 pcs

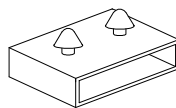

(12) Handle x 1 pc



HARDRAWE LIST

Bed Fittings

(A) Gold Bolt M8 x 18mm x 16 pcs

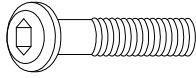

(B) Allen key M5 x 1 pc



(C) Stopper x 3 pcs

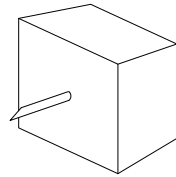

HARDRAWE LIST

Metal Frame Fittings

(D) Black Bolt M6 x 25mm x 12 pcs

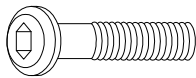

(E) Black Bolt M6 x 50mm x 12 pcs

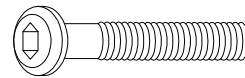

(F) Black Bolt M6 x 70mm x 4 pcs

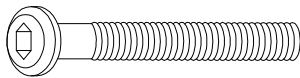

(G) Flat washer x 38 pcs

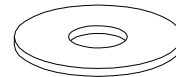

(H) Spring washer x 22 pcs

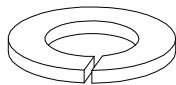

(I) Slange nut x 12 pcs

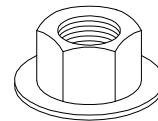

(J) Rounded nut x 6 pcs

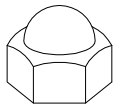

(K) Bracket x 3 pcs

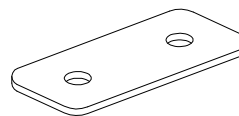

(L) Allen key M4 ball shape x 1 pc



(M) Spanner x 1 pc

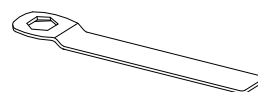

STEP 1 - ATTACHING FEET AND FIXINGS TO HEADBOARD AND FOOTBOARD

HEADBOARD

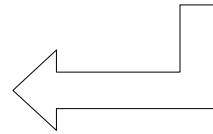
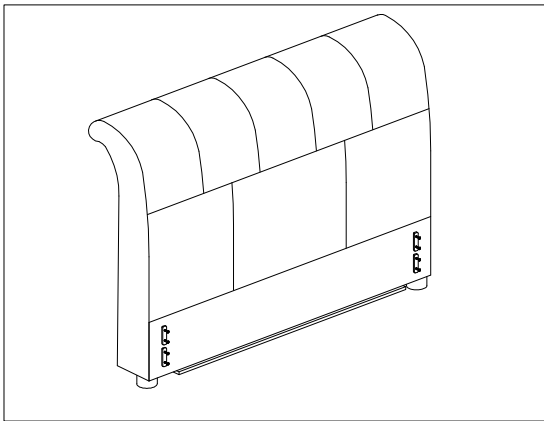
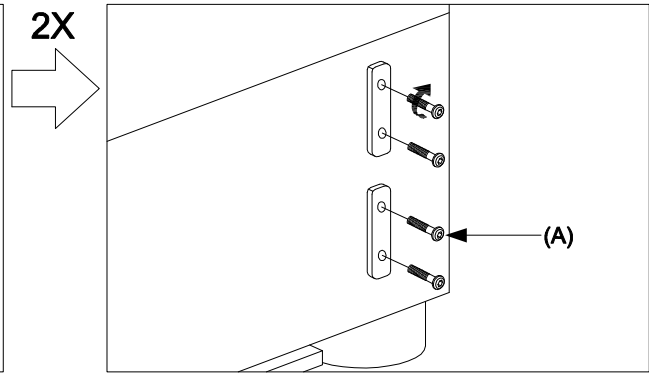
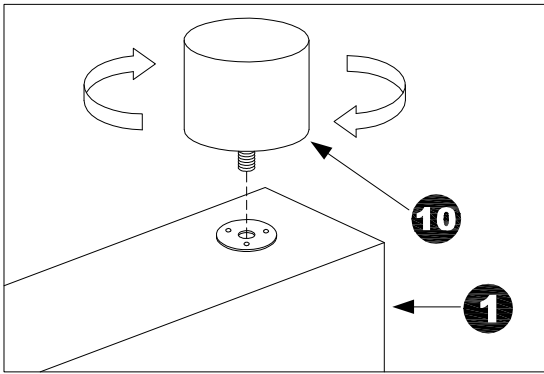

REMARK : DO NOT FULLY TIGHTEN ALL THE GOLD BOLTS M8 X18MM (A).

FOOTBOARD

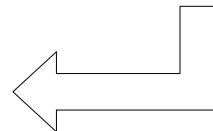
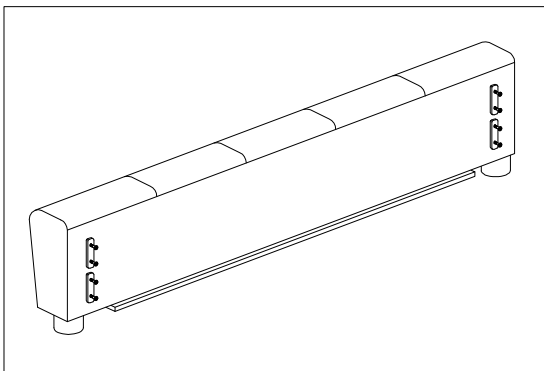
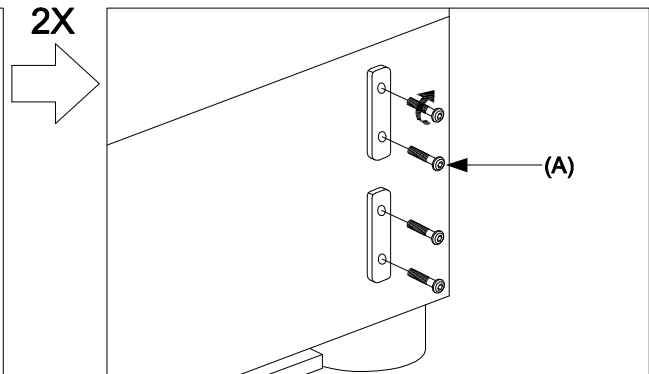
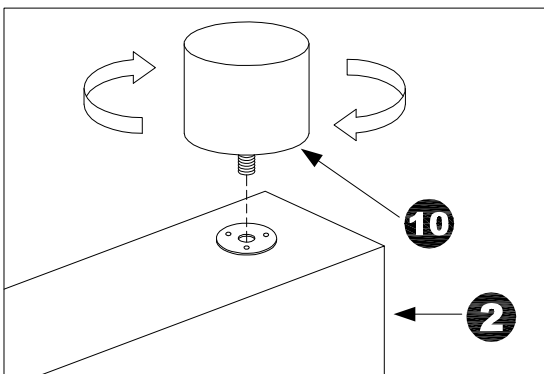

REMARK : DO NOT FULLY TIGHTEN ALL THE GOLD BOLTS M8 X18MM (A).

STEP 2 - FIXING SIDE RAILS TO HEADBOARD AND FOOTBOARD.

ALIGN AND HOOK THE SIDE RAIL BRACKET ONTO THE SCREWS IN THE METAL PLATE ON THE HEADBOARD. DO LIKE WISE WITH FOOTBOARD. REPEAT PROCESS WITH THE OPPOSITE SIDE RAIL. ENSURING FOUR CORNERS ARE AT 90°. DO NOT FULLY TIGHTEN ALL THE BOLTS.

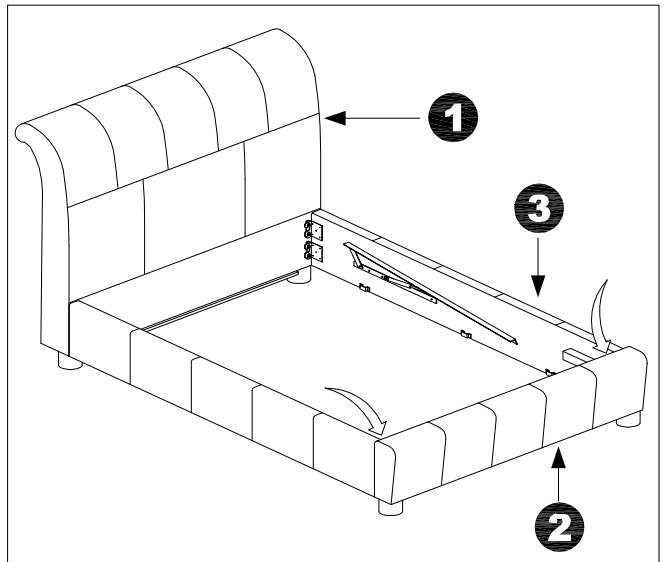
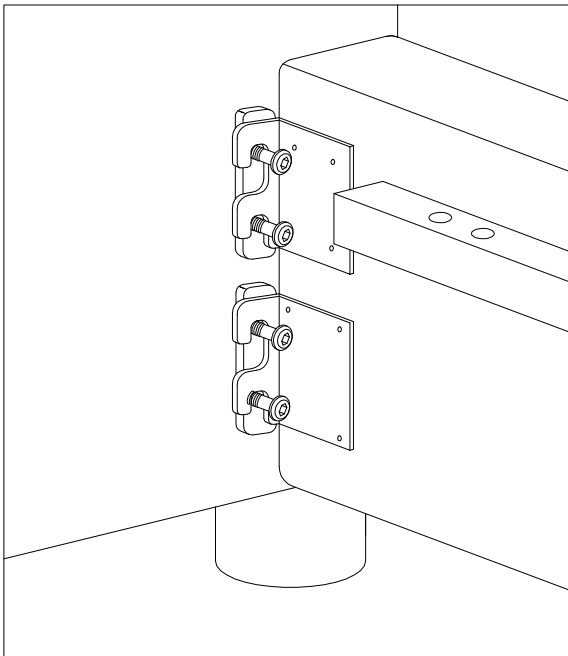
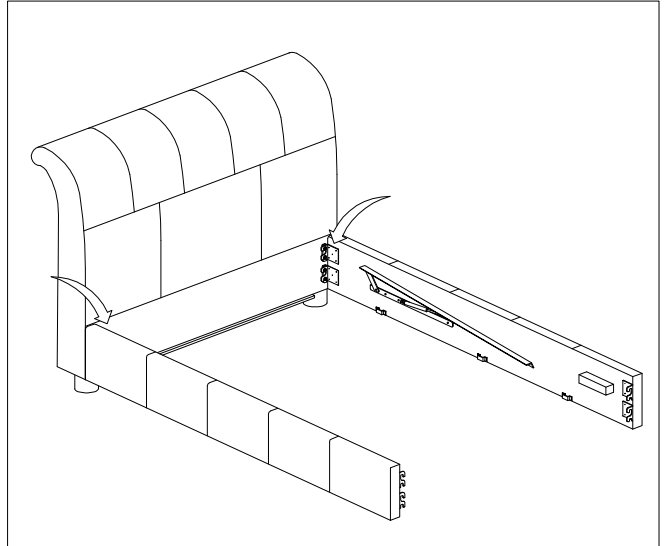
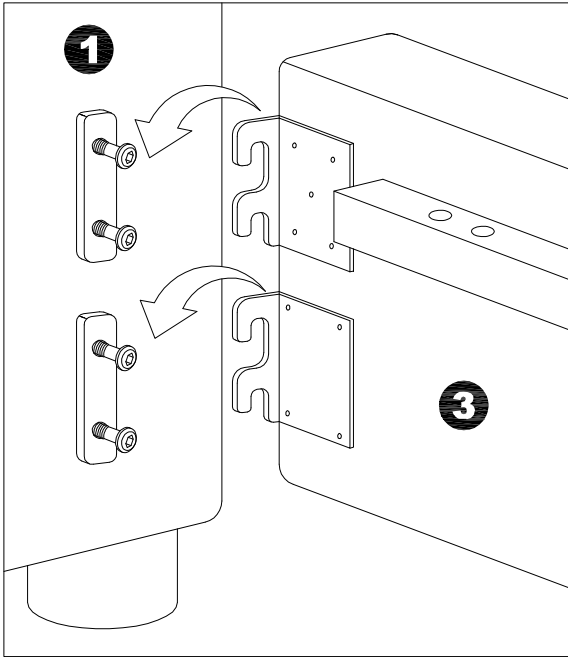

STEP 3 - ATTACHING WOODEN HORIZONTAL SUPPORTS TO MAIN FRAME

SLOT THE WOODEN HORIZONTAL SUPPORT L-BRACKET DOWNWARDS INTO THE BRACKET ON THE BOTH SIDE RAILS.

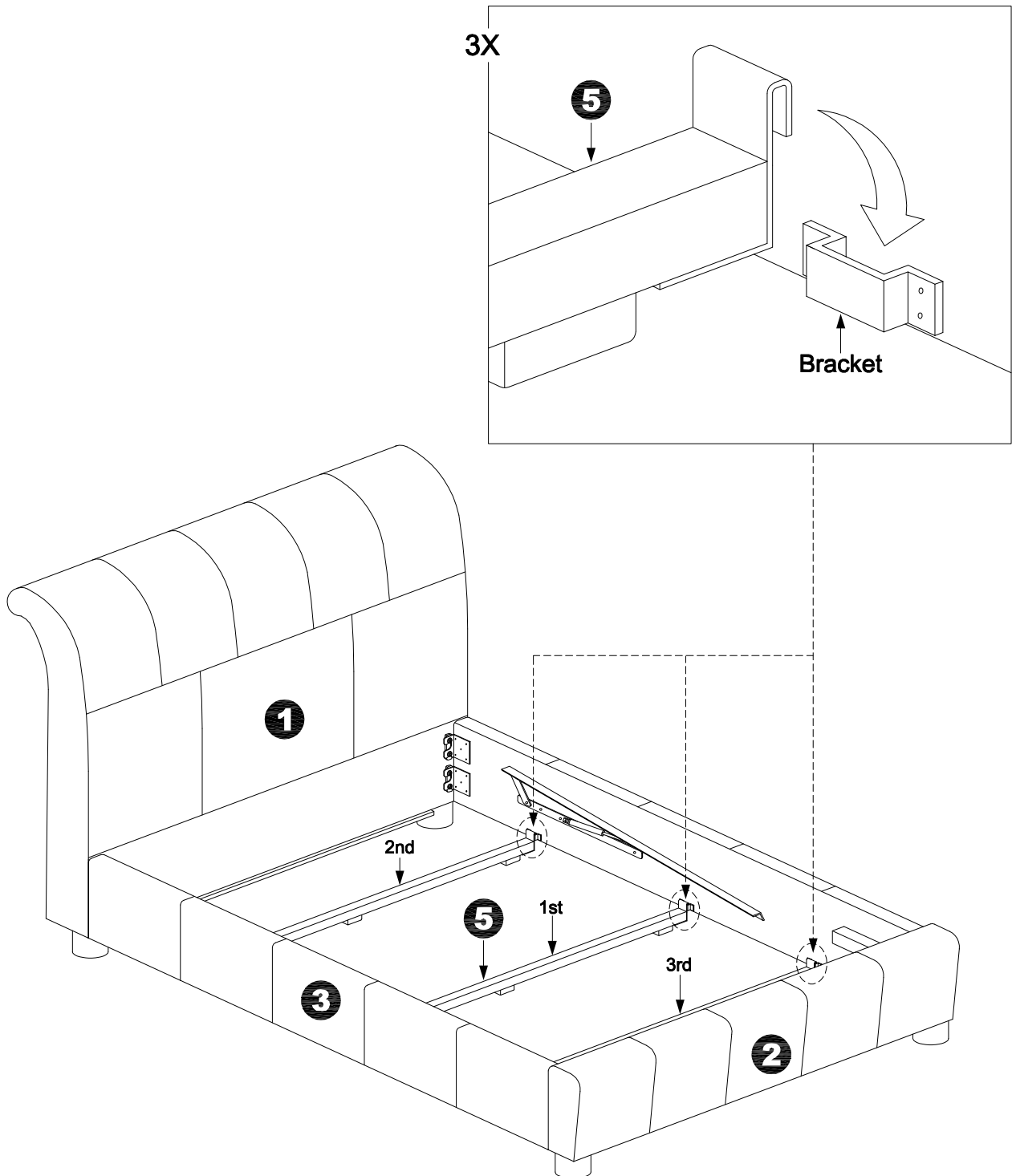

REMARK : BE CAREFUL, DO NOT CATCH THE LEATHER OR FABRIC AND WOVEN HORIZONTAL SUPPORTS ONTO BOTH SIDES OF THE SIDE RAIL.

STEP 4 - PLACING STORAGE BASE BOARDS IN OTTOMAN.

4.1

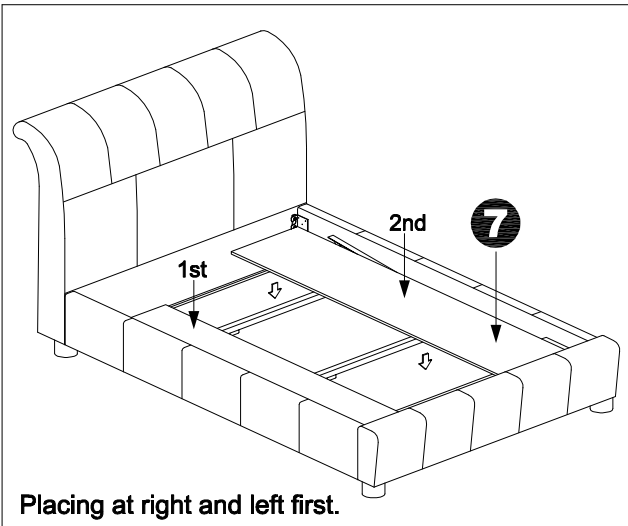

4.2

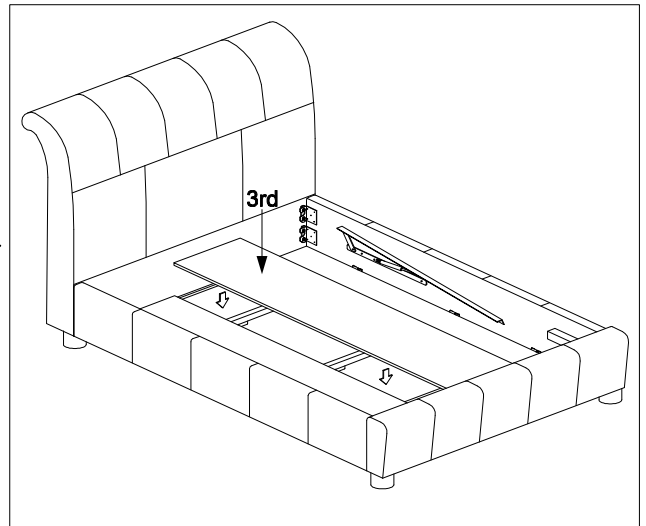

4.3 : HAMMER 3 OF THE PLASTIC STOPPERS (C) INTO FOOTBOARD AS SHOWN (OPTIONAL)

4.4 : FULLY TIGHTEN ALL THE JCBC M8 X 18MM (A) IN THE INSIDE FOUR CORNERS OF THE BED BY USING ALLEN KEY M5 (B).

4.3

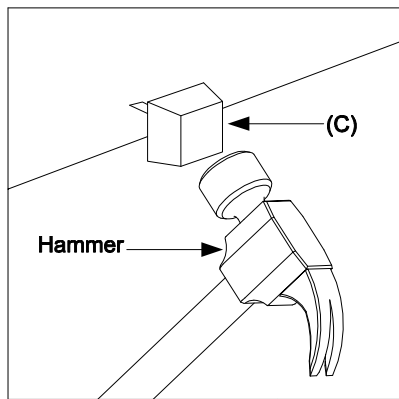

4.4

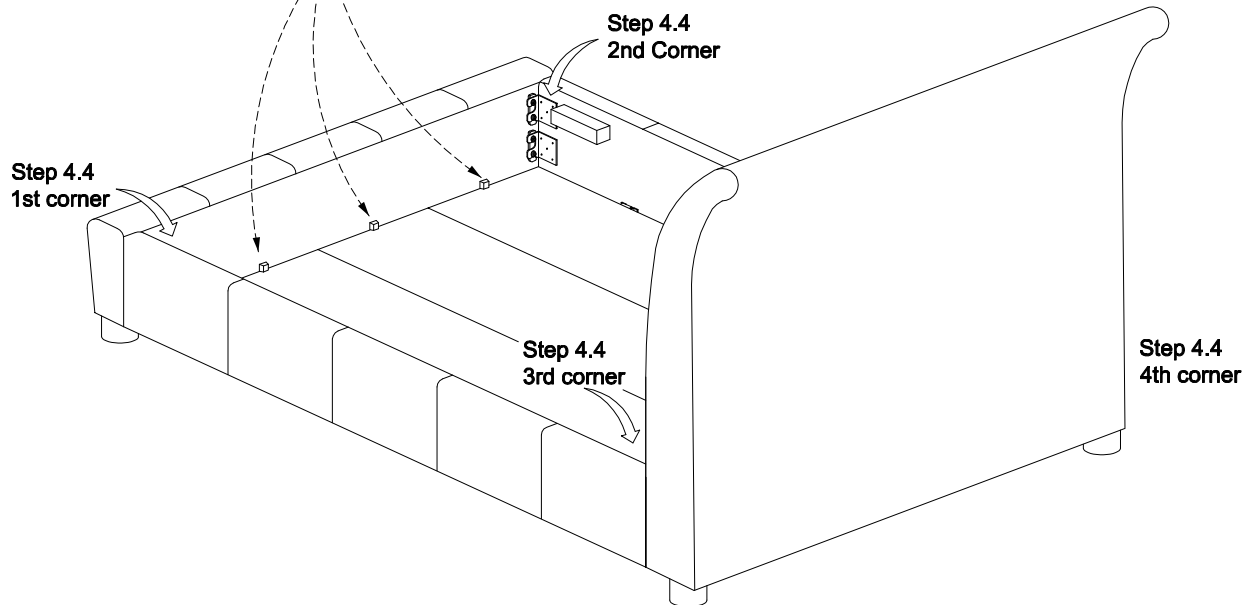
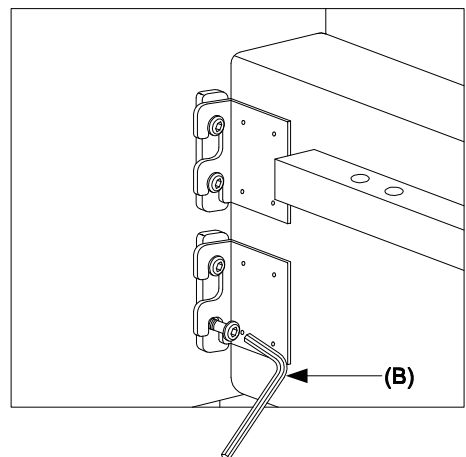

STEP 5 - FIXING LIFT UP MECHANISM ON SIDE RAILS.

LOOSEN NUT AS SHOWN (5.1), LIFT UP FRAME AND LOCATE END OF CYLINDER. ATTACH AS SHOWN (5.2) AND TIGHTEN THE NUT BY USING A SPANNER. REPEAT FOR BOTH SIDES.

5.1

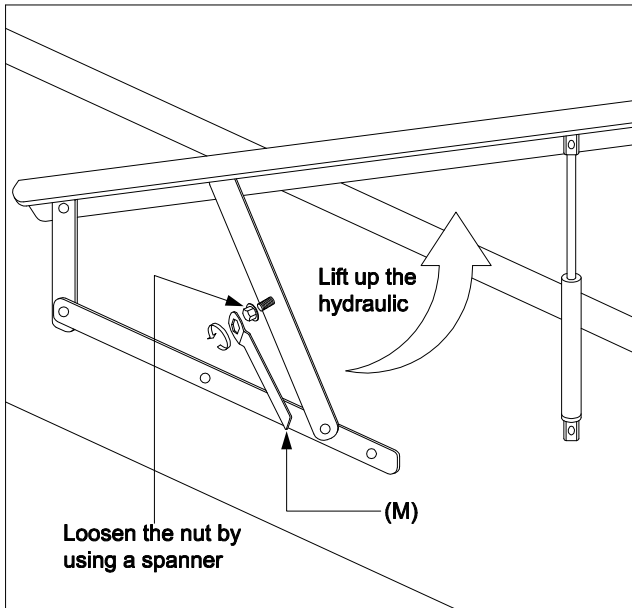

5.2

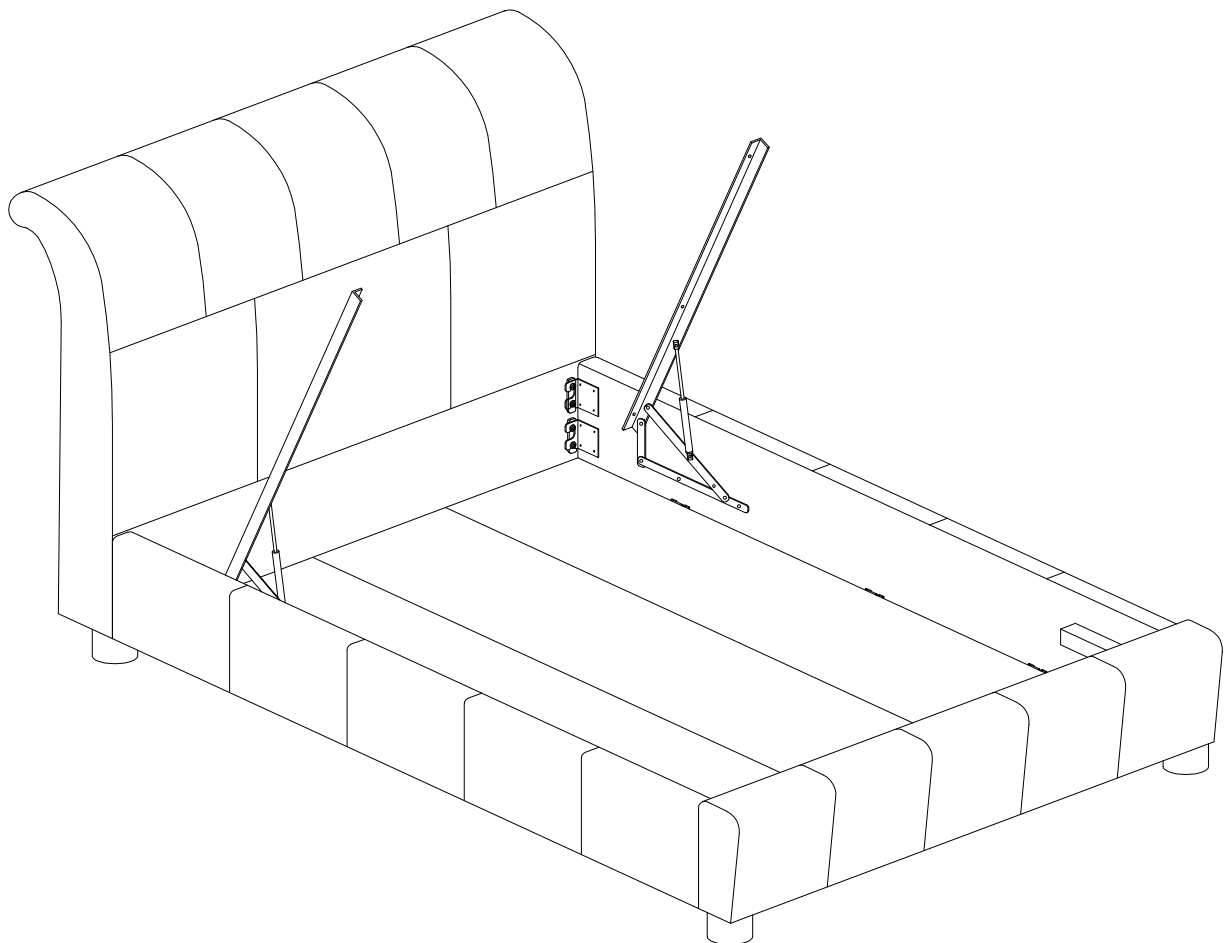
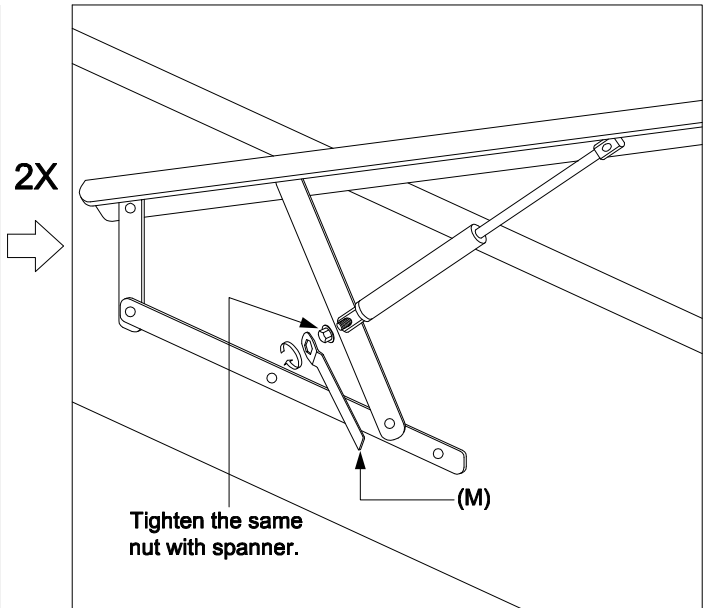

REMARK : LEAVE LIFT UP MECHANISM IN UPWARD POSITION.

STEP 6 - ASSEMBLING METAL FRAME

OPEN METAL FRAME WITH BUTTERFLY HINGES ON TOP. (DURING ASSEMBLY)
 BUTTERFLY HINGES FACE DOWNWARDS ON ASSEMBLED BED.

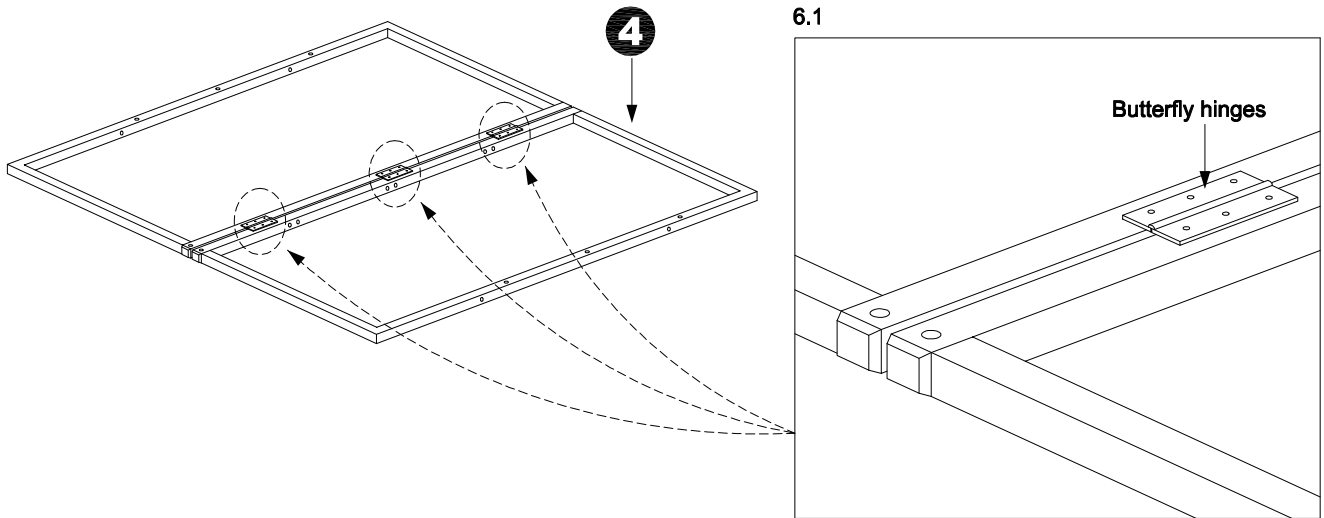

STEP 7 - ATTACH CENTRE HORIZONTAL SUPPORT.

7.1 (outside)

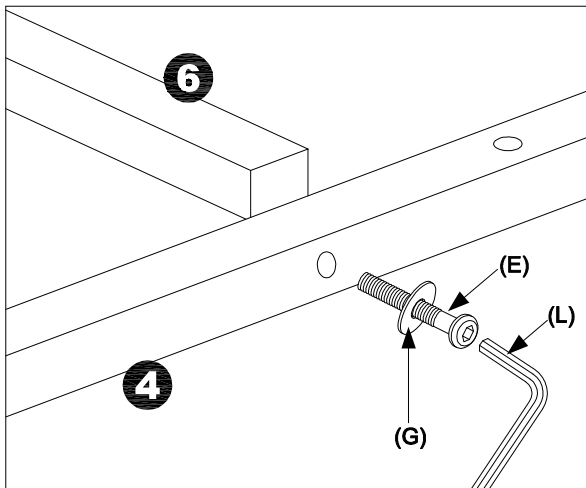

SCREW IN THE BLACK BOLT M6 X 50MM (E) AND FLAT WASHER (G) FROM OUT SIDE, AS SHOWN.

7.2 (inside)

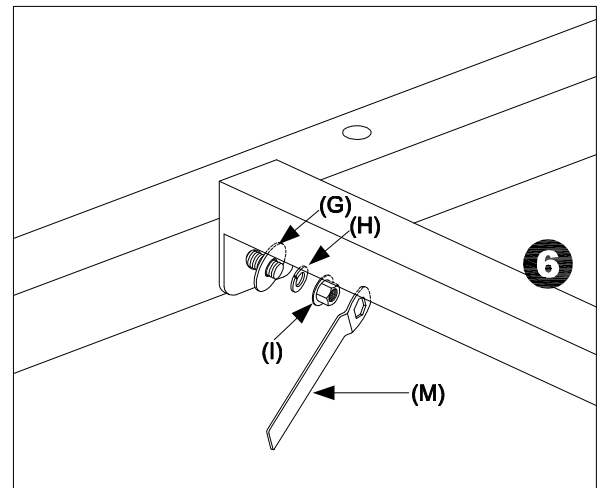

ATTACH FLAT WASHER (G), SPRING WASHER (H) AND SLANGE NUT (I) TO BOLT ON INSIDE.

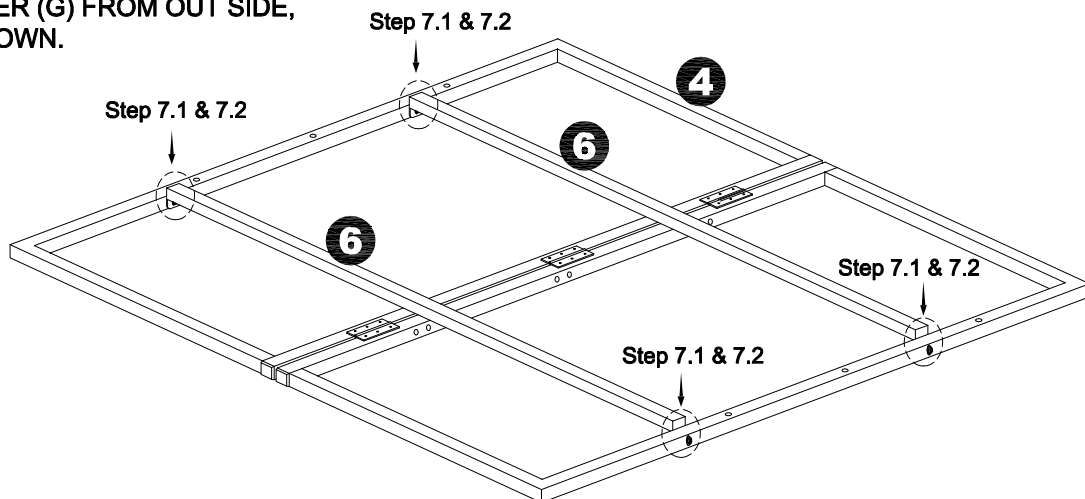

7.3 (TOP POSITION)

SCREW THE BRACKET (K) INTO THE CENTRE OF METAL HORIZONTAL SUPPORT AT THE METAL FRAME, AS SHOWN. INSERT JCBC M6 X 70MM (F) AND FLAT WASHER (G) INTO THE TOP POSITION.

7.3 (Top position)

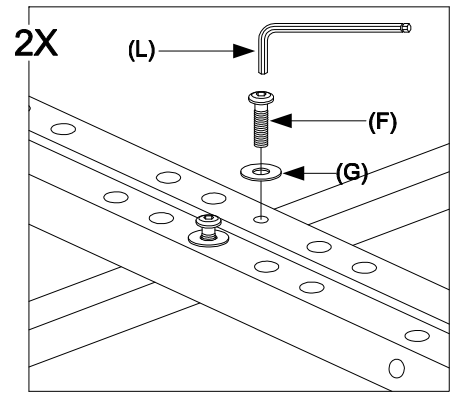

7.4 (TOP POSITION) - ASSEMBLE THE HANDLE

INSERT JCBC M6 X 50MM (E) AND FLAT WASHER (G) INTO THE SCREW HOLE AT THE FRONT OF METAL FRAME.

7.4 (Top position)

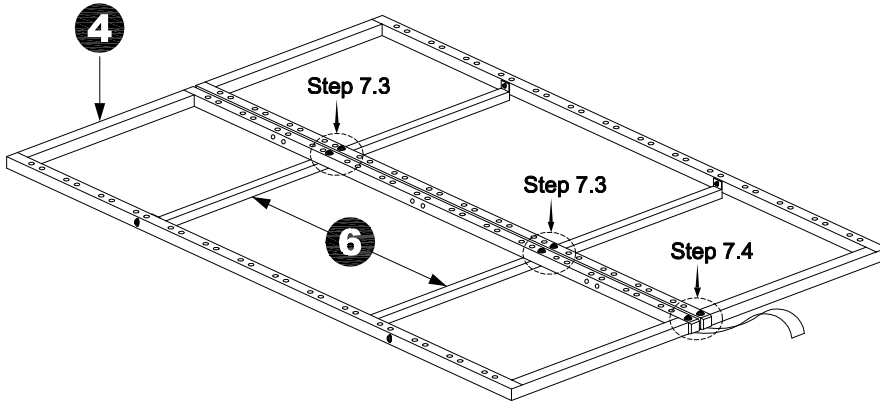
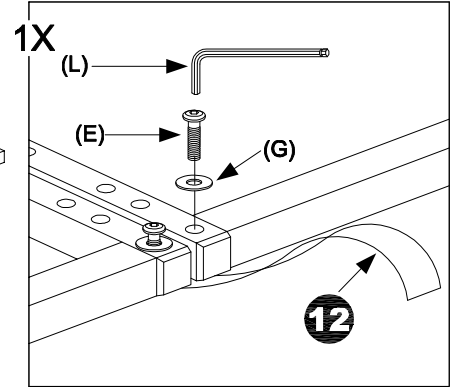

7.5 (BASE POSITION)

INSERT ROUNDED NUT (J) AT THE BOLT BASE AND TIGHTEN WITH SPANNER (M).

7.5 (Base position)

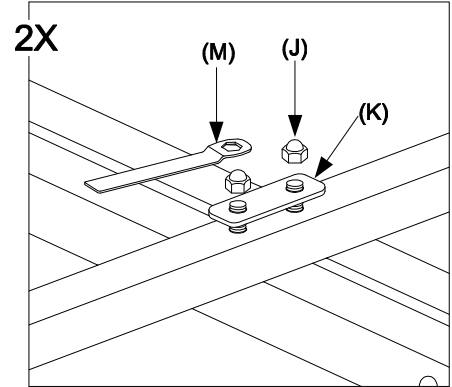

7.6 (BASE POSITION) - ASSEMBLE THE HANDLE

INSERT SLANGE NUT (I) AND ROUNDED NUT (J) AT THE BASE OF BOLT AND TIGHTEN WITH SPANNER (M).

7.6 (Base position)

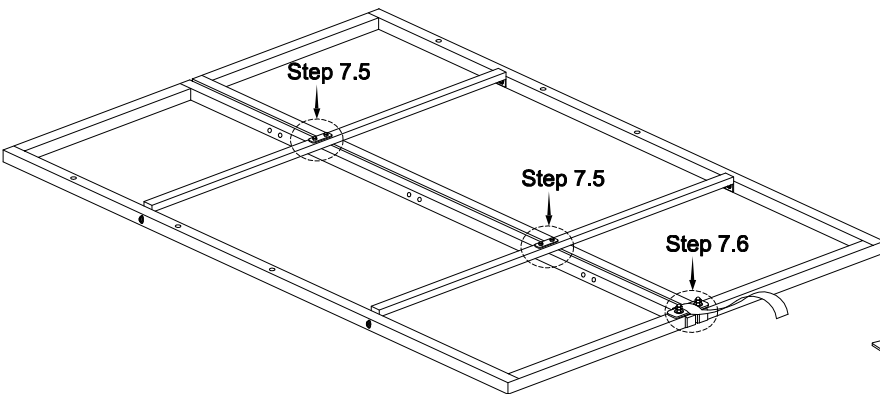
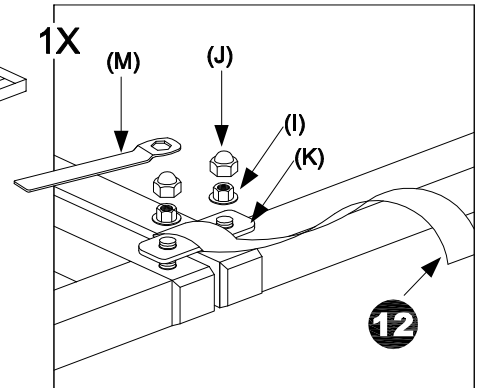

NOTE : FULLY TIGHTEN THE BLACK BOLT WITH ALLEN KEY M4 AND THE ROUNDED NUT WITH SPANNER TOGETHER.

7.7 - ASSEMBLE THE METAL SUPPORT LEGS

PLACE THE METAL SUPPORT LEG INTO THE METAL FRAME BY FOLLOW THE SCREW HOLES. INSERT JCBC M6 X 25MM (D), FLAT WASHER (G) AND SPRING WASHER (H) INTO THE SCREW HOLES AT THE METAL SUPPORT LEG. DO THE SAME STEP FOR ANOTHER SIDE AT THE SAME METAL SUPPORT LEG AND FULLY TIGHTEN WITH ALLEN KEY M4 (L).

REMARK :
TIGHTEN SCREWS EACH TIME.
NO NUT NEEDED FOR STEP 7.7.

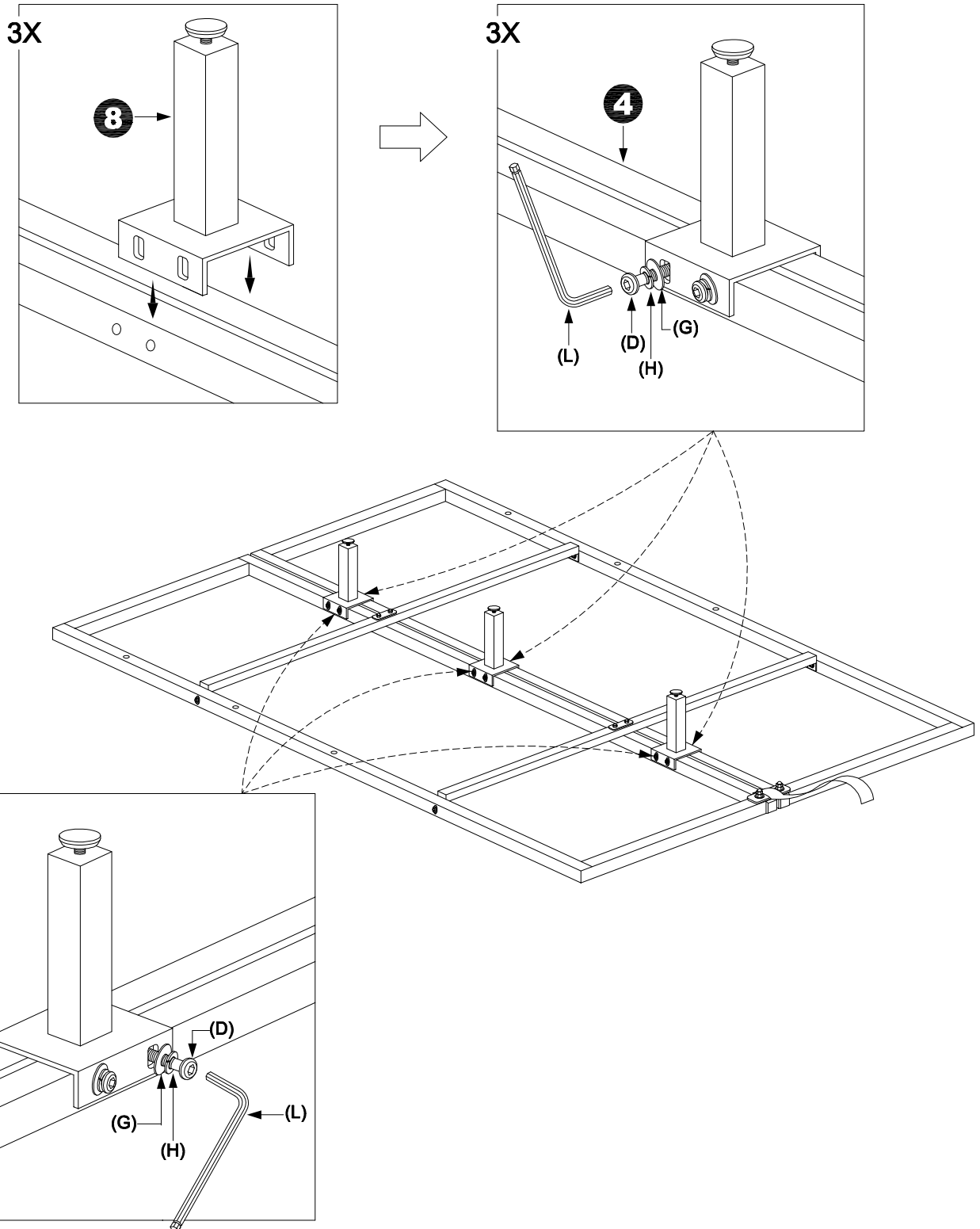

STEP 8 - ATTACHING BED SLATS TO METAL FRAME.

8.1

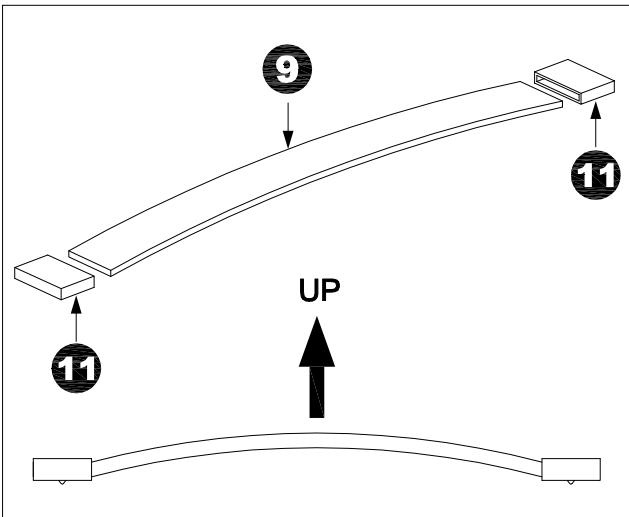

8.2

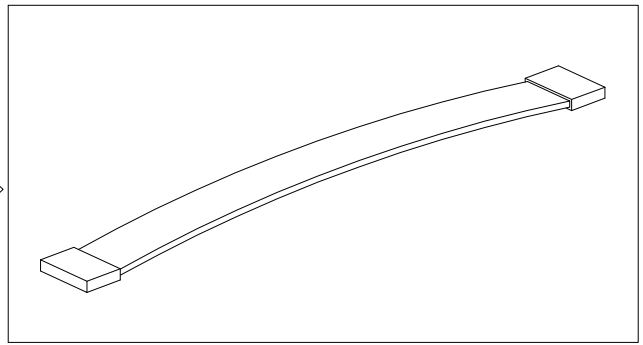

ATTACH PLASTIC CAP ON BOTH SIDE OF SLAT.

8.3

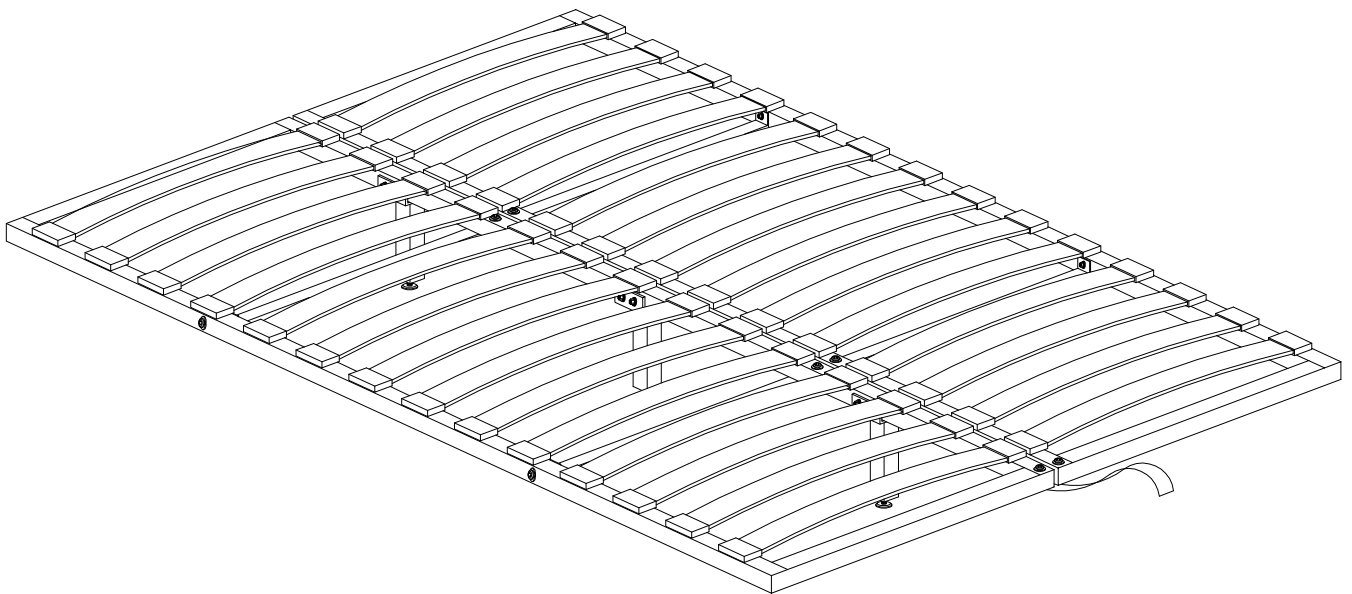
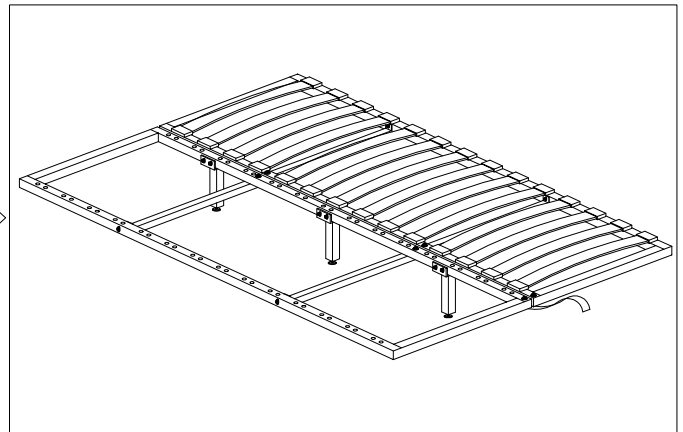
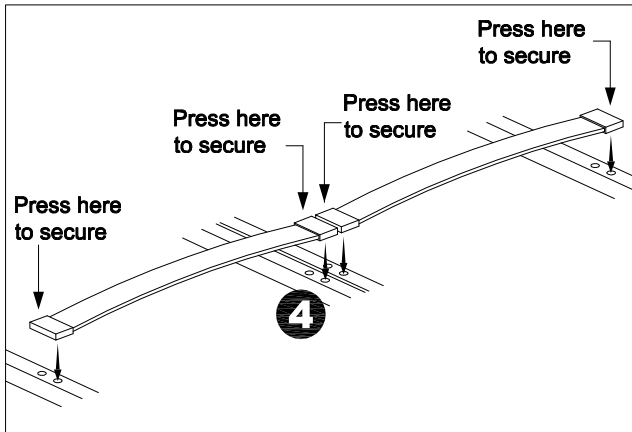

REMARK : ONCE BED IS ASSEMBLED, DO NOT SIT, STAND OR APPLY WEIGHT DIRECTLY TO SLATS UNLESS MATTRESS IS IN PLACE.

STEP 9 (i) - ATTACHING METAL FRAME TO OTTOMAN.

CONNECT THE METAL FRAME BASE TO THE METAL SIDE SUPPORT WITH THE BENT SALTS FACING UPWARDS.

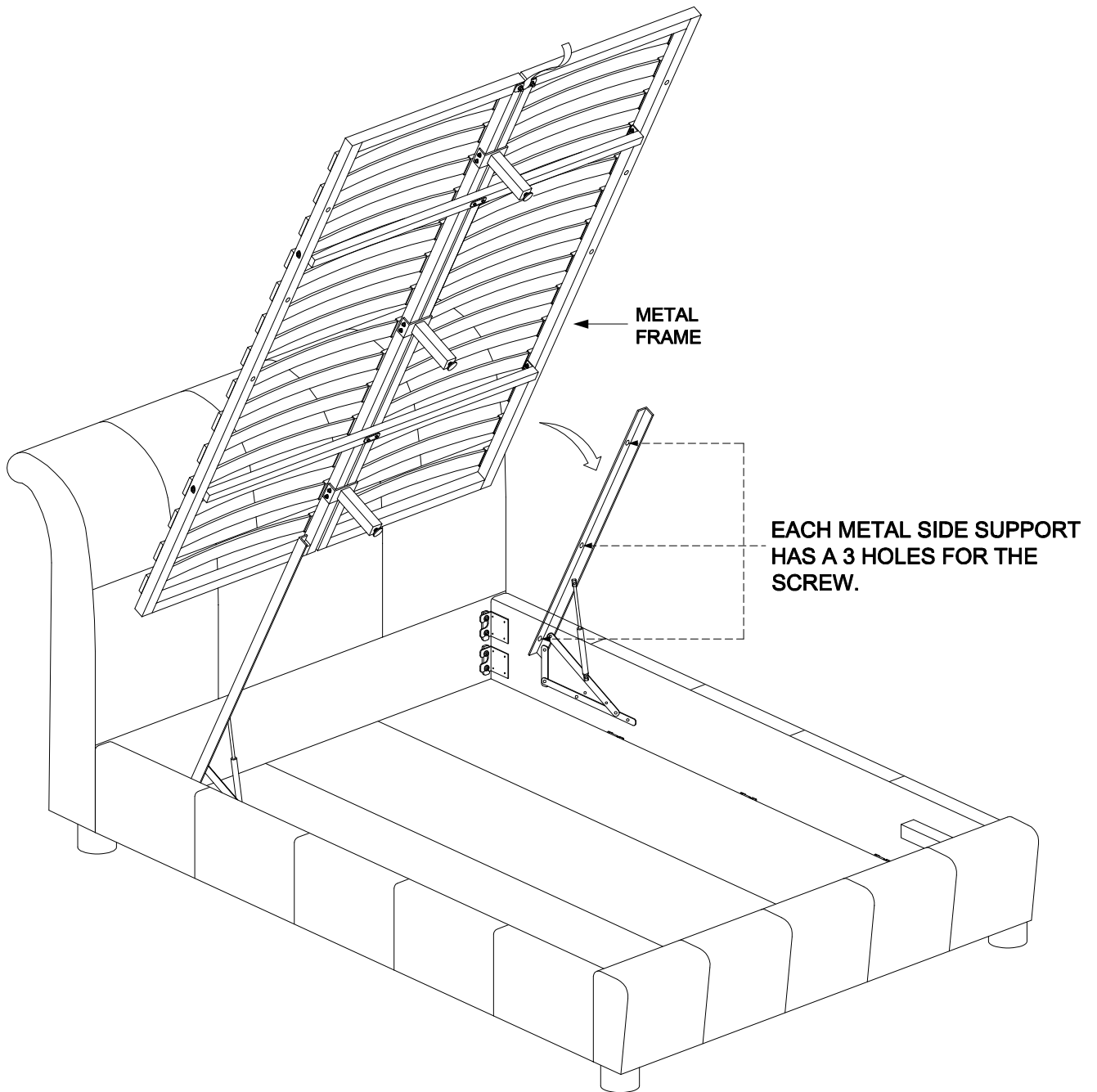

STEP 9 (ii)

INSERT BLACK BOLT M6 X 50MM (E) AND FLAT WASHER (G) INTO THE SCREW HOLE AT THE METAL FRAME AND METAL SIDE SUPPORT. THEN, INSERT FLAT WASHER (G), SPRING WASHER (H) AND SLANGE NUT (I) AT THE BASE OF SAME BOLT.

NOTE :

FULLY TIGHTEN THE BLACK BOLT WITH ALLEN KEY M4 AND SLANGE NUT WITH SPANNER TOGETHER.

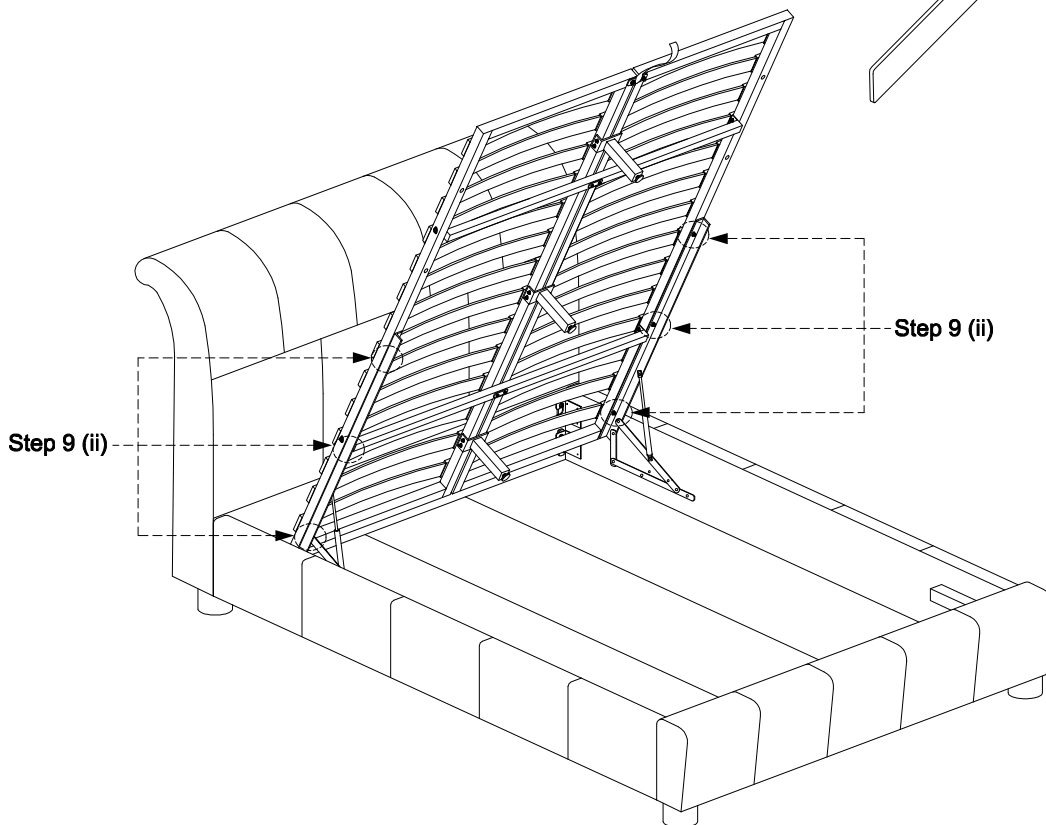
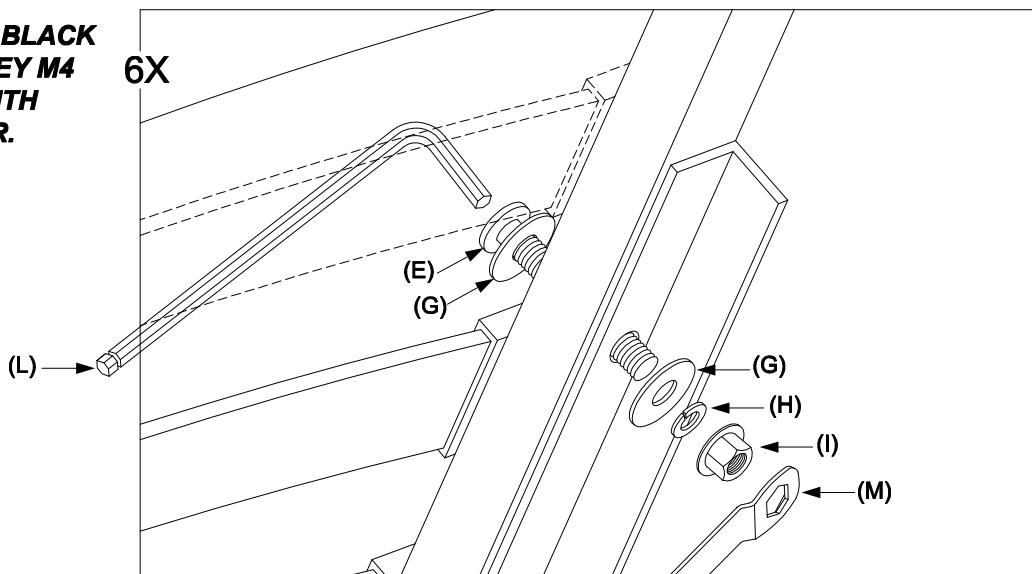

REMARK :

FINALLY, PLACE MATTRESS ON FRAME THEN SLOWLY PUSH DOWN METAL FRAME ENSURING THE FRAME IS FULLY ALIGNED WITH THE SIDE RAIL.

STEP 10

BEFORE USING BED. (AFTER FULL ASSEMBLY OF THE BED AND ONCE A MATTRESS IS IN PLACE.)

BEFORE USING THE BED, PLEASE OPERATE THE LIFT ACTION SEVERAL TIMES TO ENSURE SMOOTH OPERATION. THE HYDRAULIC CYLINDER MAY HAVE SMALL OIL RESIDUES OF THEM, THIS IS NORMAL AND CAN BE EASILY REMOVED WITH PAPER TOWEL OR SIMILAR MATERIALS.

ATTENTION

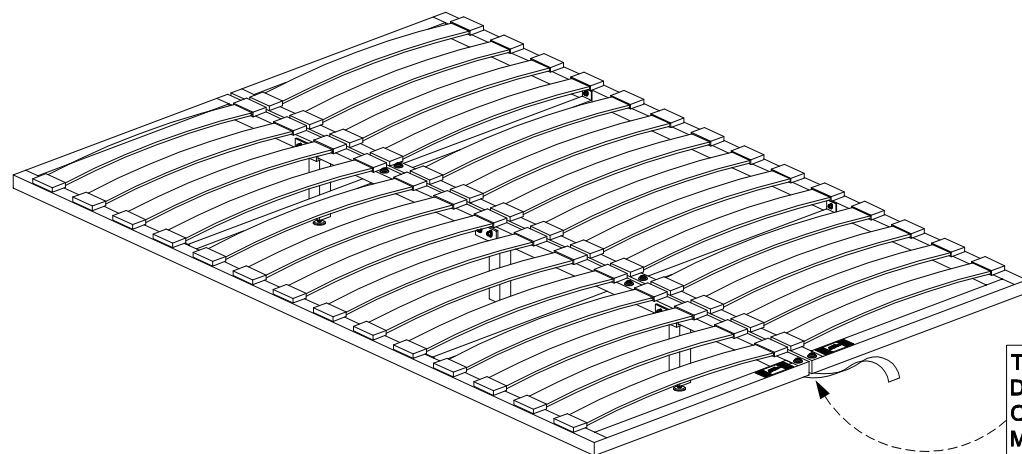
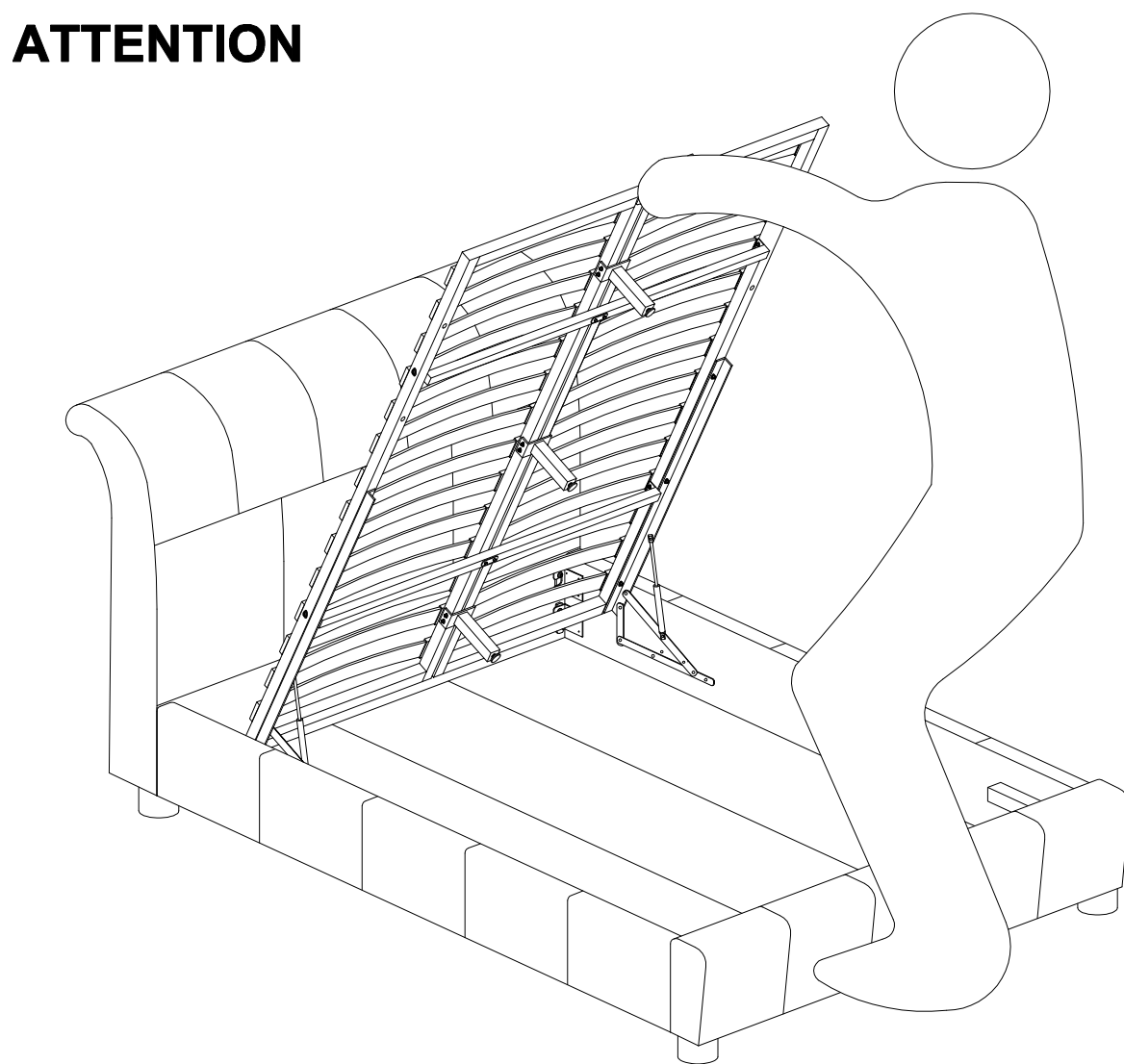

TO AVOID MISALIGNMENT AND DAMAGING THE BED BASE PLEASE OPEN AND CLOSE FROM THE MIDDLE OF THE END BASE AS SHOWN IN THE INSTRUCTIONS.