

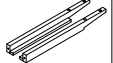

ASSEMBLY INSTRUCTIONS

MODEL: B6582-Q-HB / B6582-K-HB

Thank you for purchasing this quality product. Be sure to check all packing material carefully for small parts which may have come loose inside the carton during shipment. Identify and count all parts and compare with hardware list as below:

STEP 1

(BOX 1) BOX OF HEADBOARD			
ITEM	DRAWING	DESCRIPTION	QTY
A		HEAD BOARD	1
B		HB LEG POST (L/R)	2

(BOX 1) BOX OF HEADBOARD (HARDWARE LIST)				
ITEM	DRAWING	DESCRIPTION	DIMENSION	QTY
C		JCBC (M8) WITH WASHER	8 x P1.25 x 50MM	4
D		ALLEN KEY M5	5 x 120MM	1

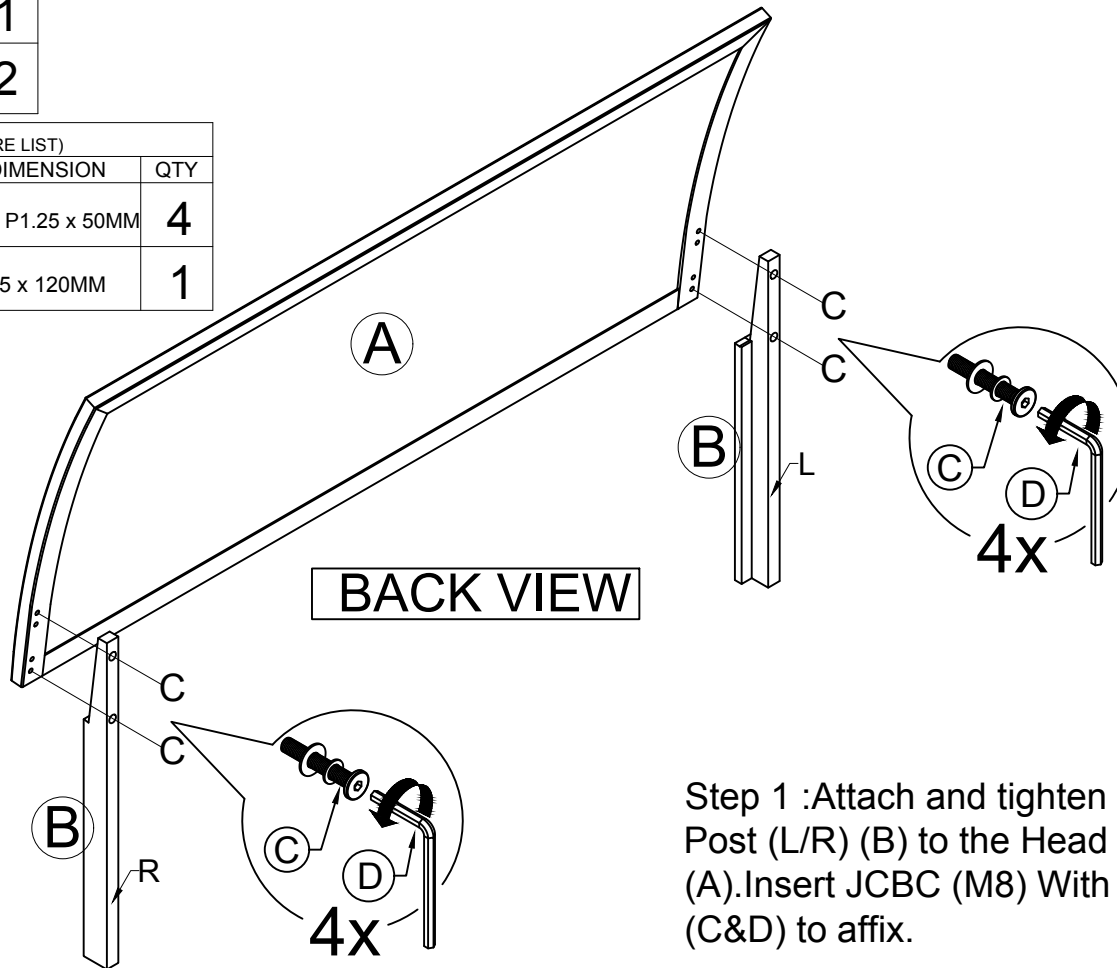

BACK VIEW

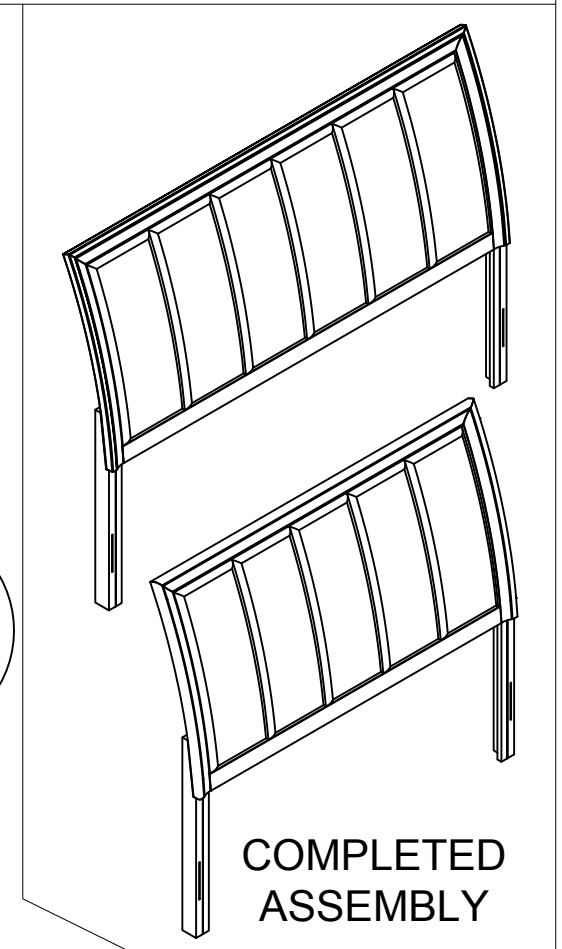

COMPLETED ASSEMBLY

Step 1 : Attach and tighten the Leg Post (L/R) (B) to the Head Board (A). Insert JCBC (M8) With Washer (C&D) to affix.

NOTE: MUST TIGHTEN SCREW PERIODICALLY. WITH USE SCREWS WILL BECOME LOOSE CHECK TIGHT OF ALL SREWS EVERY 6-8 WEEKS.

CLEANING INSTRUCTION

After assembled, clean & polish the complete parts if necessary with soft cloth and industrial recognized furniture polish.

MADE IN MALAYSIA