

# ASSEMBLY INSTRUCTION

# HN-2018-190 MINI SLEEPER (CHEST)

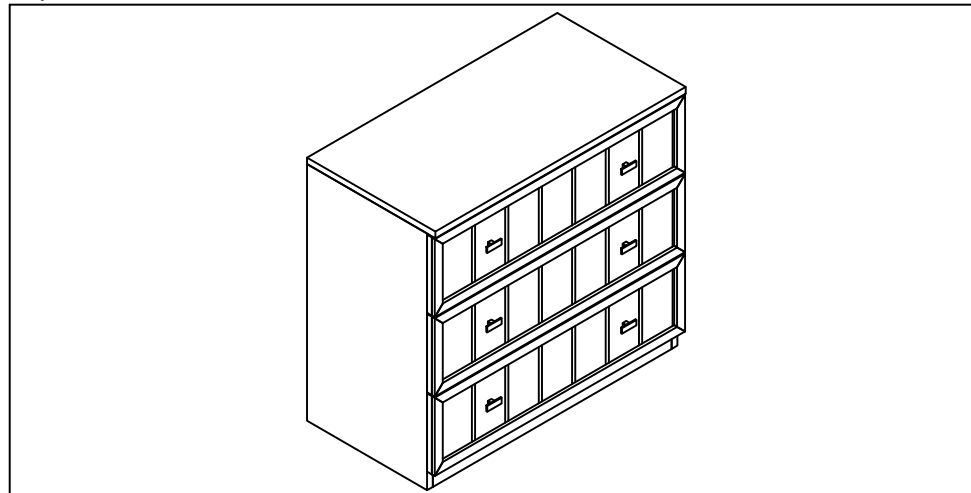

Thank you for purchasing this quality product. Be sure to check all packing material carefully for small parts that may have come loose inside the carton during shipment.

### COMPONENT LISTS



### HARDWARE LISTS

NO	DESCRIPTION	QTY
A	 Dowel Ø8 X 30mm	8
B	 Minifix 24mm	24
C	 Minifix 34mm	8
D	 CSK Screw Ø3.5 x 16mm	18

NO	DESCRIPTION	QTY
E	 Dowel Ø6 X 30mm	12
F	 Handle Screw 4 X 30mm	6
G	 Handle	6

\*Screw driver is not provided.

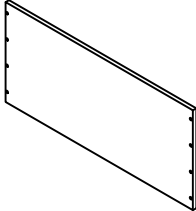
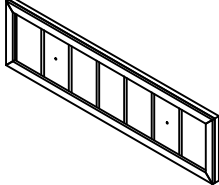
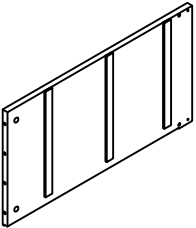
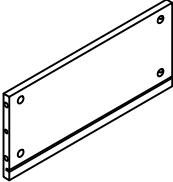
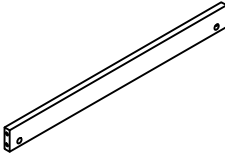
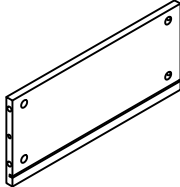
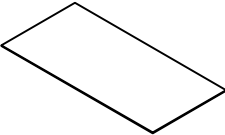
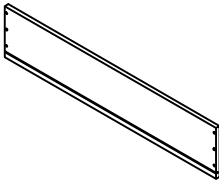
NO	DESCRIPTION	QTY	NO	DESCRIPTION	QTY
1	 Top Panel	1	5	 Drawer Front	3
2	 Side Panel	2	6	 Drawer Side (Left)	3
3	 Strips	1	7	 Drawer Side (Right)	3
4	 Drawer Bottom	3	8	 Drawer Back	3

EXAMPLE FOR SKETCH ONLY

MADE IN MALAYSIA

## STEP 1

Slot in the Drawer Bottom to Drawer Side Left and Right. Use Dowels and Minifix (24mm) to connect drawer's parts. Further tighten the Minifix by using screw driver. Complete the step for other Drawers.

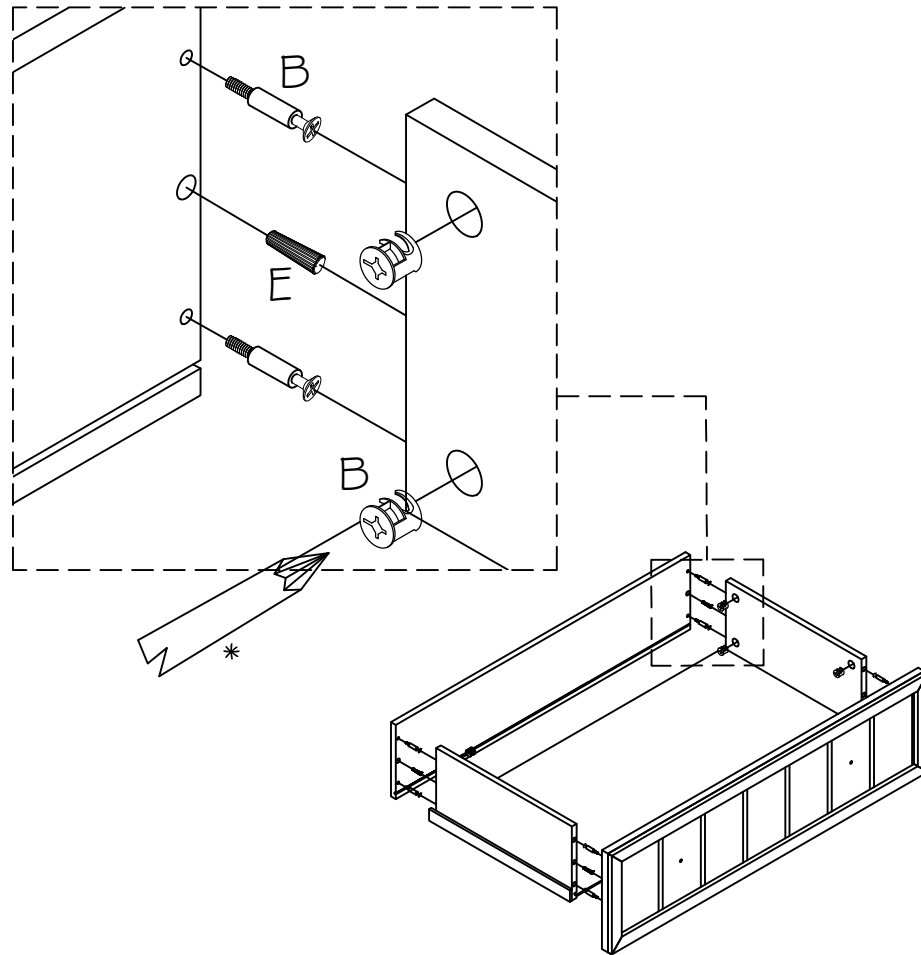

## STEP 2

Attach Handles to Drawer Front with Handle Screw by using screw driver.

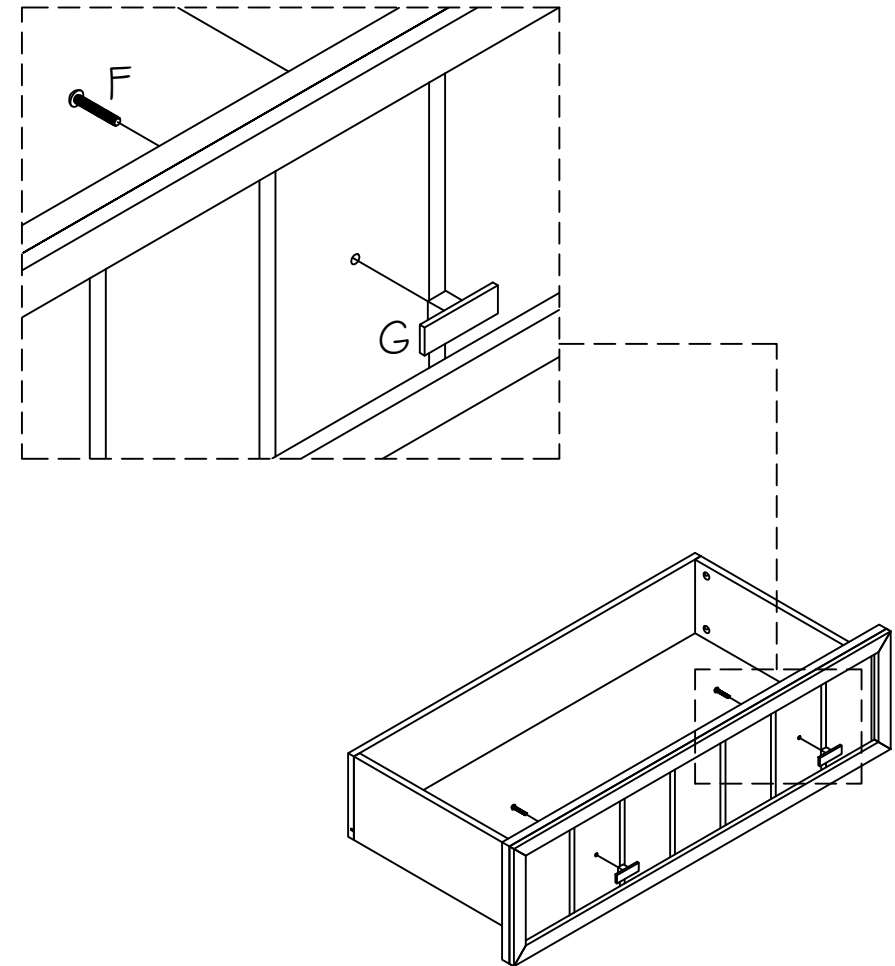

## STEP 3

Use Dowel and Minifix (34mm) to Connect Side Panel and Strips. Further tighten the Minifix by using Screw Driver.

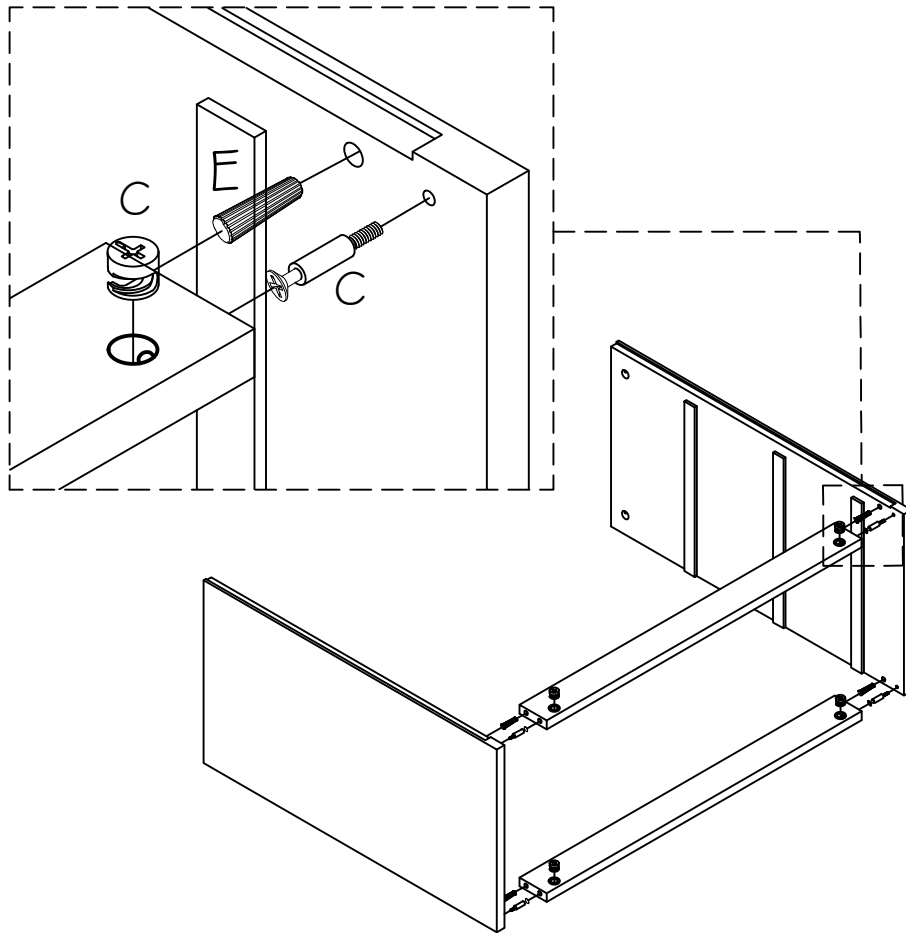

## STEP 4

Use Dowel and Minifix (34mm) to fix Top Panel to Side Panel. Further tighten the Minifix by using Screw Driver.

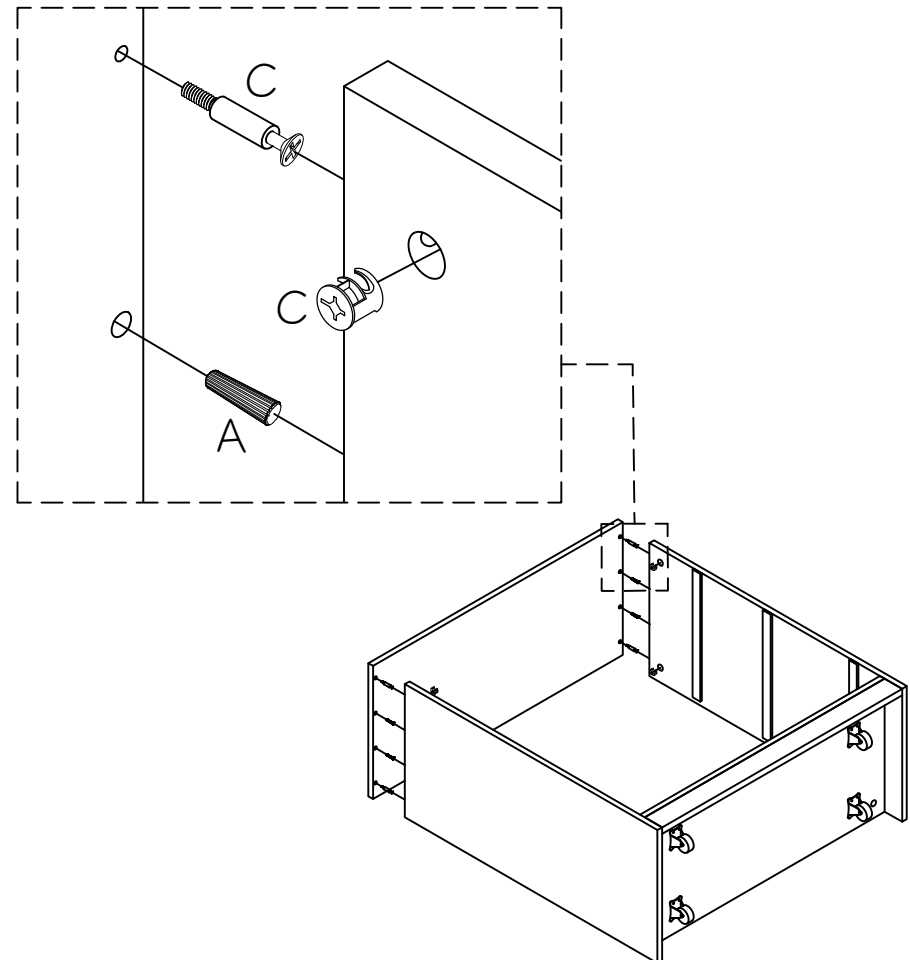

## STEP 5

Use Back Panel to cover the back part of the Cupboard by using CSK Screw.

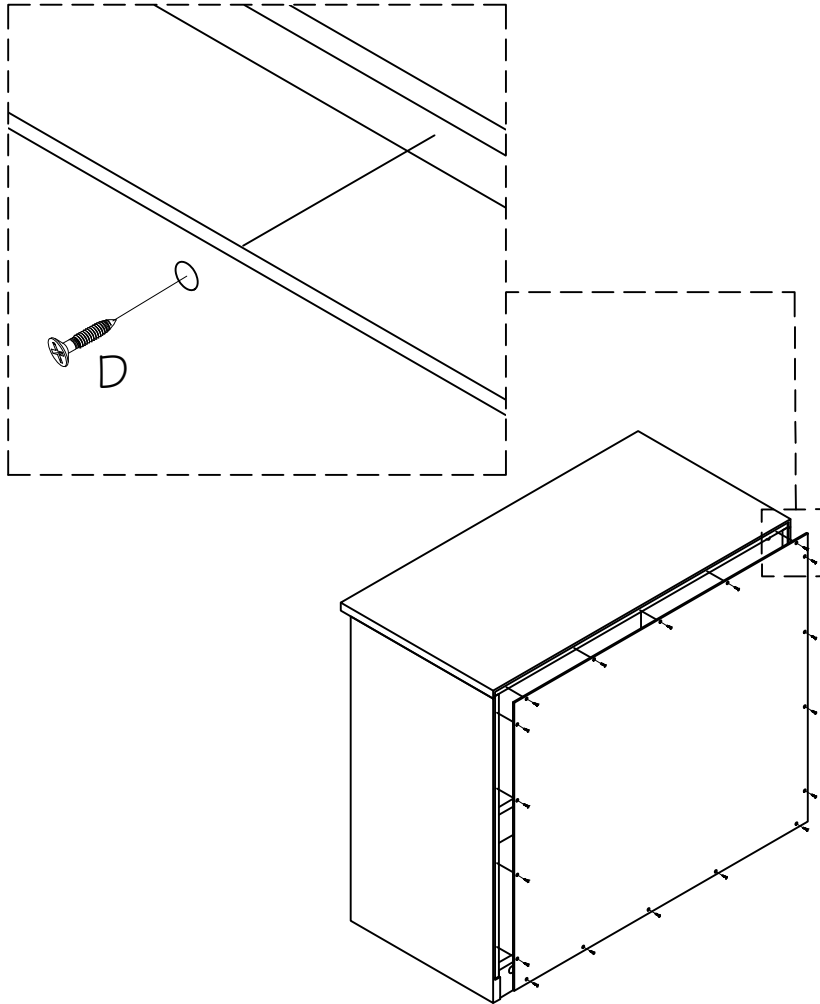

## STEP 6

Insert the drawers to the Cupboard accordingly.

