

ASSEMBLY INSTRUCTION

HN-2018-190 MINI SLEEPER

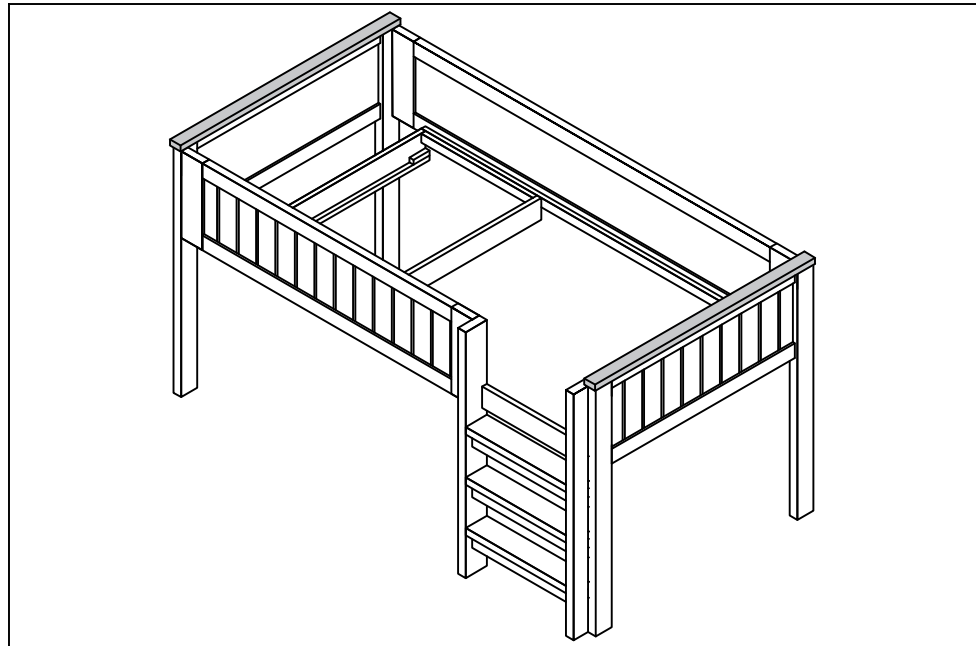



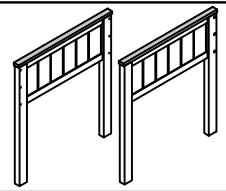
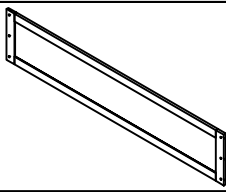
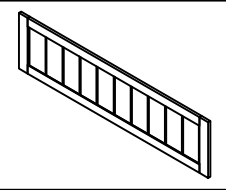
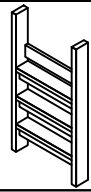
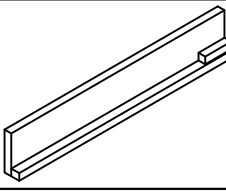
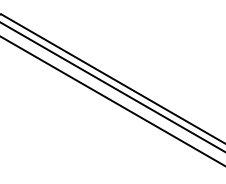

Thank you for purchasing this quality product. Be sure to check all packing material carefully for small parts that may have come loose inside the carton during shipment.



COMPONENT LISTS

NO	DESCRIPTION	QTY
1	 HEADBOARD & FOOTBOARD	2
2	 SIDE RAIL (LEFT)	1
3	 SIDE RAIL (RIGHT)	1
4	 LADDER	1
5	 SIDE PANEL TRACK	1
6	 STRIP	1

HARDWARE LISTS

NO	DESCRIPTION	QTY	NO	DESCRIPTION	QTY
A	 CSK Screw Ø4 x 30mm	4	E	 Allen Key M4	1
B	 JCBC Ø6 x 30mm	7	F	 Barrel Nut	12
C	 JCBC Ø6 x 50mm	3	G	 Plastic Cap	9
D	 JCBC Ø6 x 80mm	9			

STEP 1

Set up the Side Rail (Left) to the Headboard and Footboard with JCBC screw (80mm) and Barrel nut by using allen key. Cover the hole with plastic cap provided.

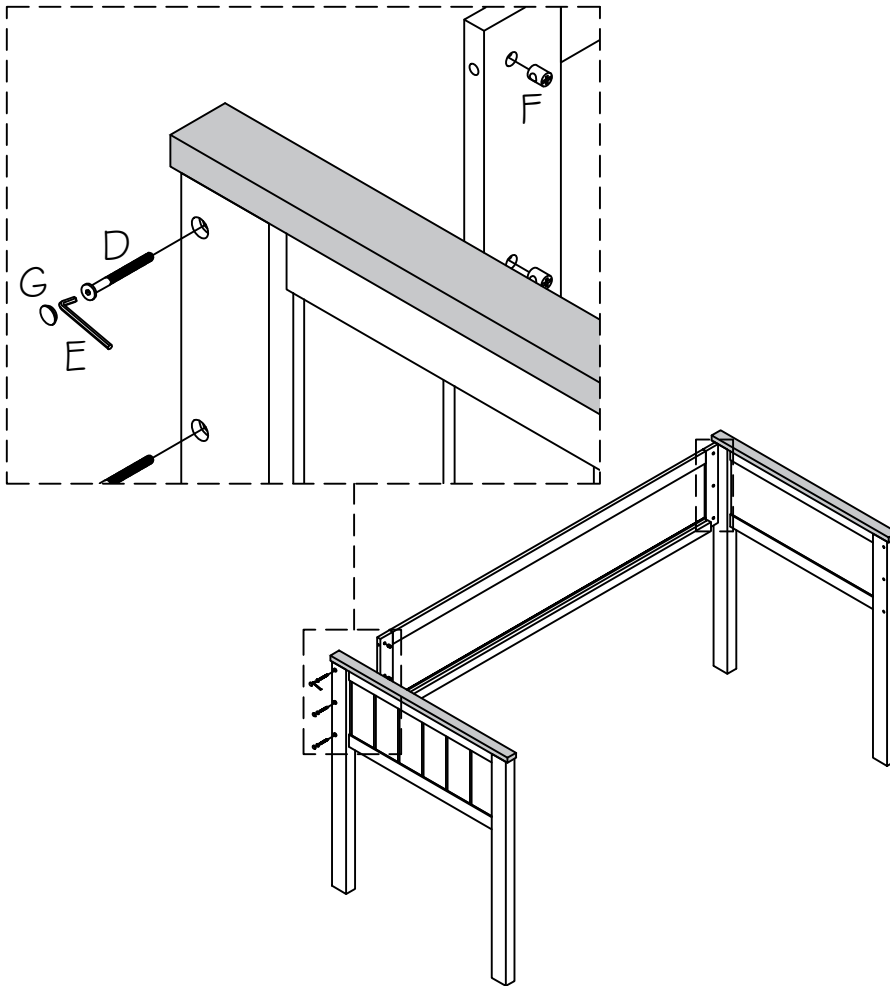

EXAMPLE FOR SKETCH ONLY

STEP 2

Attach Ladder to the Footboard with JCBC (50mm) by using allen key.

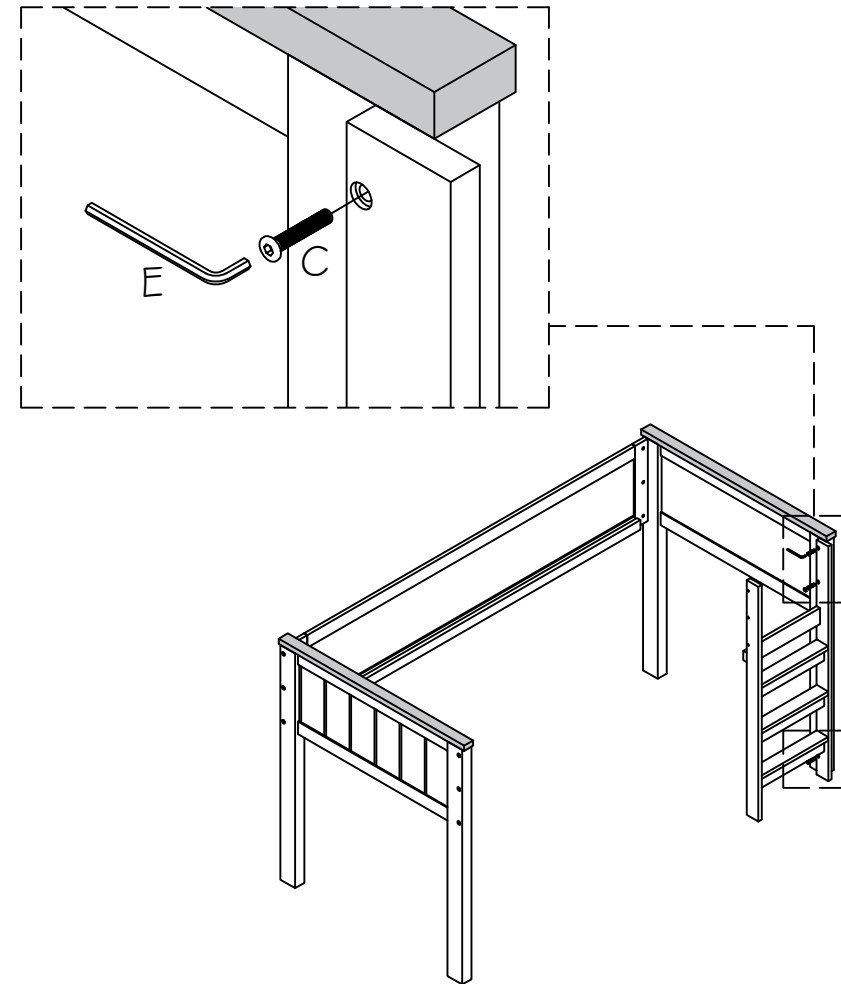

MADE IN MALAYSIA

STEP 3

Set up the Side Rail (Right) to the Headboard with JCBC screw (80mm) and Barrel nut by using allen key. Cover the hole with plastic cap provided.

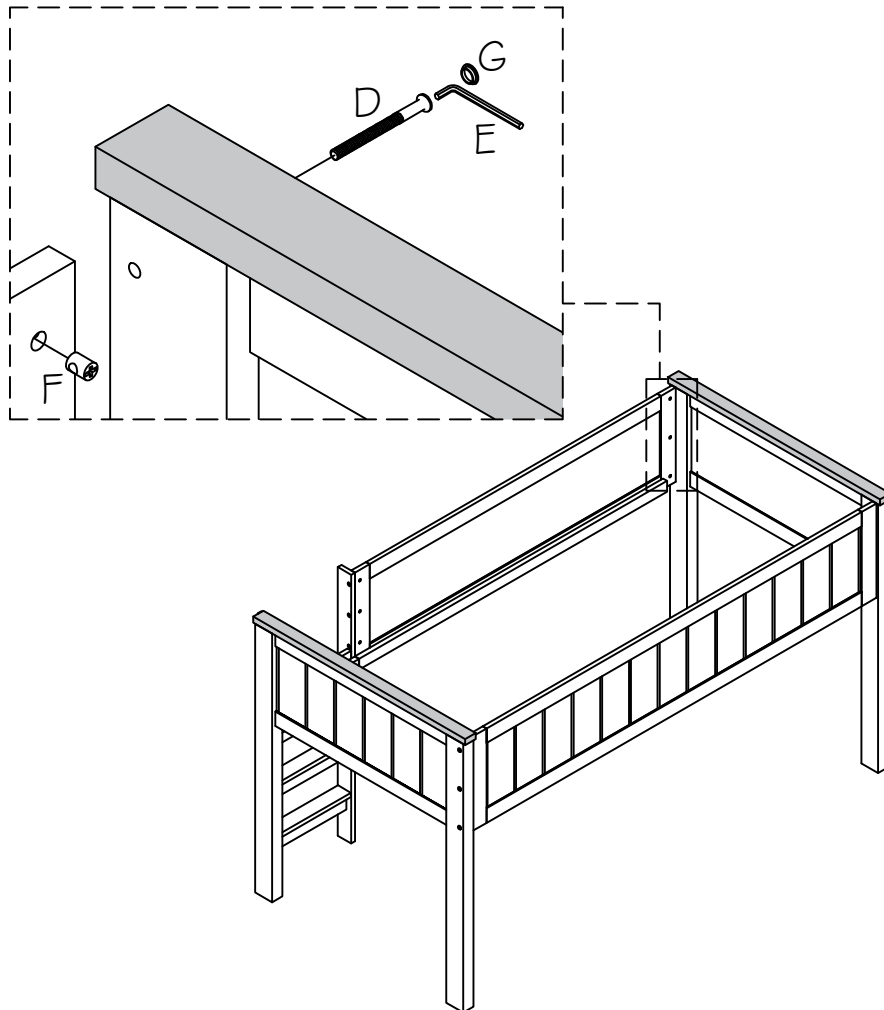

STEP 4

Attach Side Rail (Right) to the Ladder with JCBC screw (30mm) and Barrel nut by using allen key.

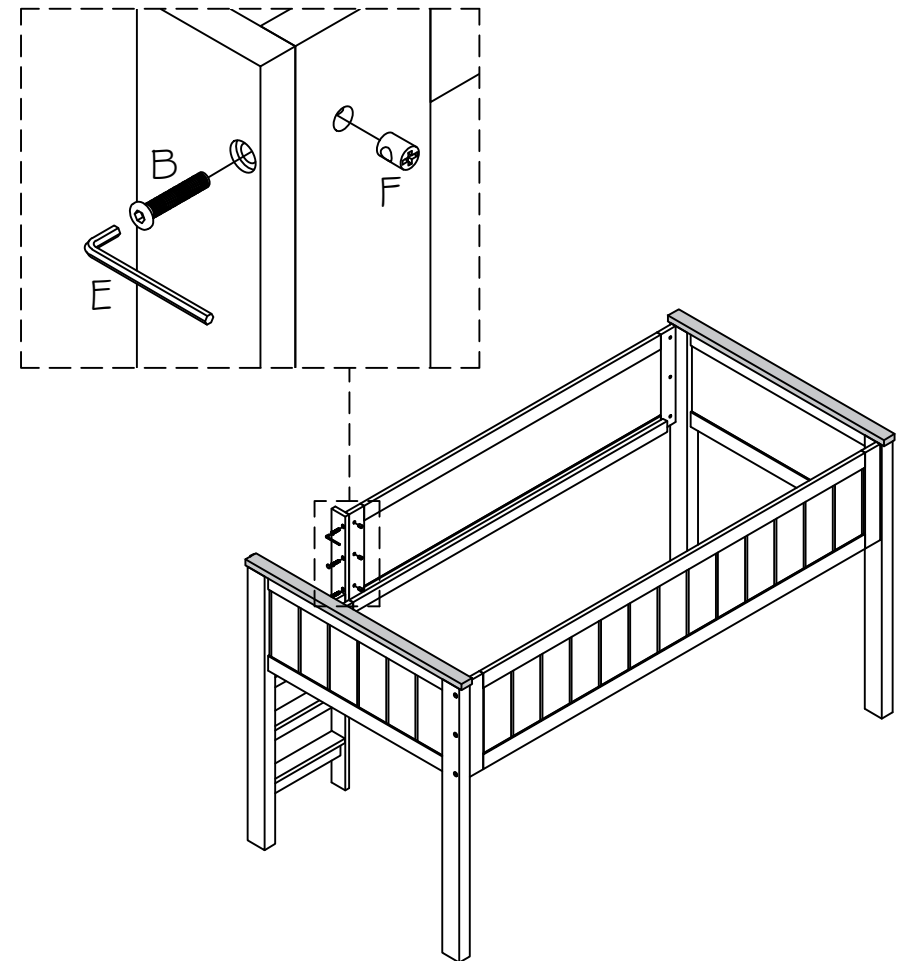

STEP 5

Attach the Side Panel Track to the Strip with JCBC screw (30mm).

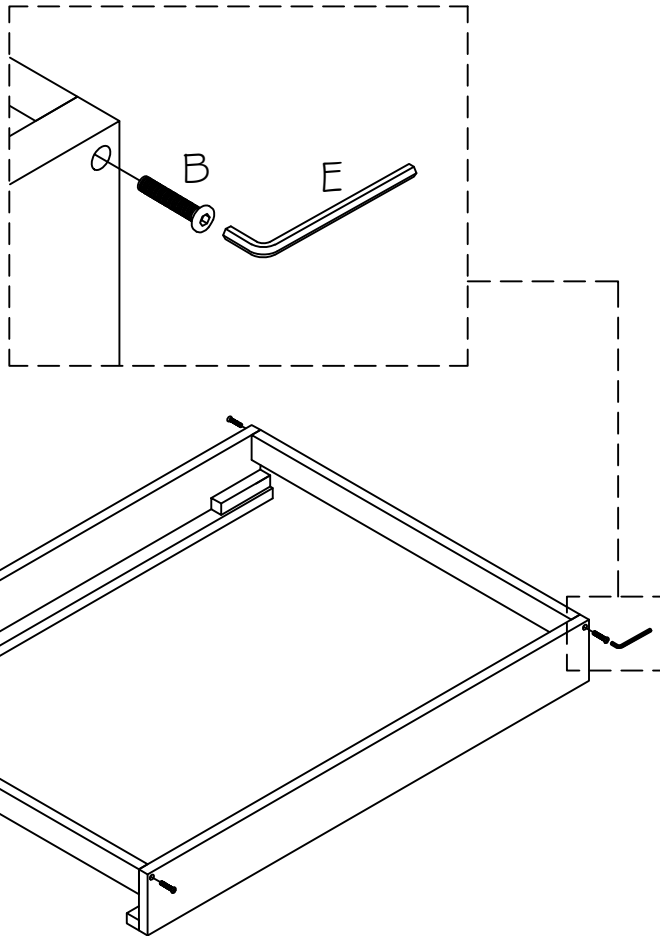

STEP 6

Attach the Roller Track to side rail support with CSK screw.

