

ASSEMBLY INSTRUCTION

HN-2018-OCC-056-END TABLE

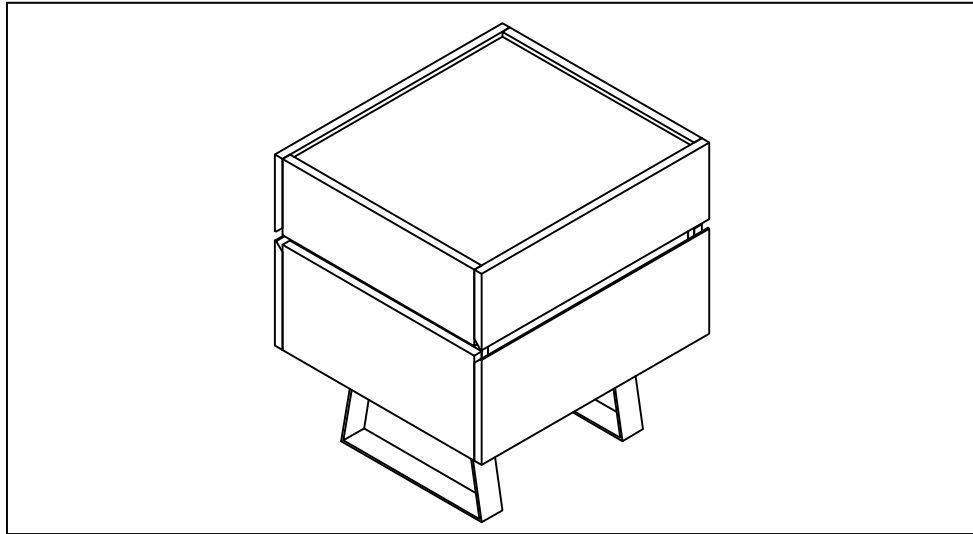

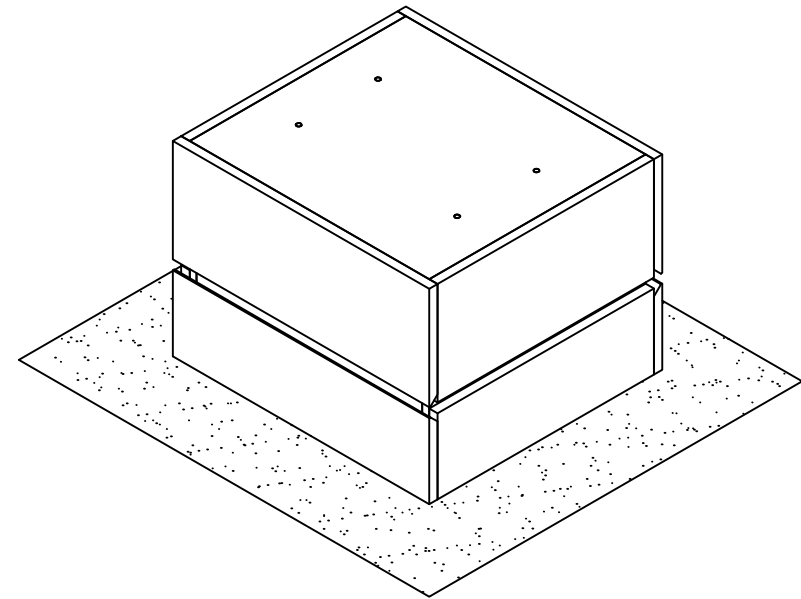

IMPORTANT !

Place the body of the end table upside down on smooth surface (For eg. Cloth, Carpet, Rug etc.) prior start of assembly.



HARDWARE LISTS

NO	DESCRIPTION	QTY
A	 JCBC Ø6 X 16mm	4
B	 Allen Key M4	1

COMPONENT LISTS

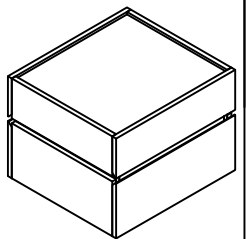
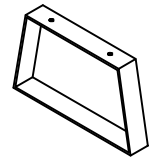
NO	DESCRIPTION	QTY	NO	DESCRIPTION	QTY
1	 Body	1	2	 Metal Legs	2

EXAMPLE FOR SKETCH ONLY

MADE IN MALAYSIA

STEP 1

Use allen key to tighten the JCBC Screw into metal legs until the JCBC Screw are totally in.

