

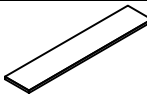

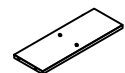







ASSEMBLY INSTRUCTION

LV-2016-186 DESK&HUTCH

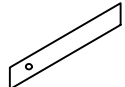

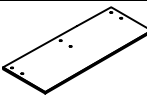

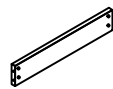



Thank you for purchasing this quality product. Be sure to check all packing material carefully for small parts that may have come loose inside the carton during shipment.

COMPONENT LISTS

NO	DESCRIPTION	QTY
1	 Hutch Top	1
2	 Hutch Shelf	1
3	 Hutch Divider	1
4	 Hutch Right Panel	1
5	 Hutch Left Panel	1
6	 Hutch Center Panel	1
7	 Hutch Short Strip	1
8	 Hutch Long Strip	1
9	 Hutch Back Panel	1

NO	DESCRIPTION	QTY
10	 Desk Top	1
11	 Desk Side Panel	1
12	 Desk Strip	2
13	 Desk Panel Support	1
14	 Desk Drawer	1

HARDWARE LISTS

NO	DESCRIPTION	QTY
A	 Minifix	10
B	 Dowel Ø8x30mm	8
C	 Dowel Ø6x30mm	8
D	 Csk screw 3.5x16mm	24
E	 JCBC M6 X45mm	8
F	 JCBC M6 X30mm	6
G	 JCBC M6 X40mm	4
H	 M4	1

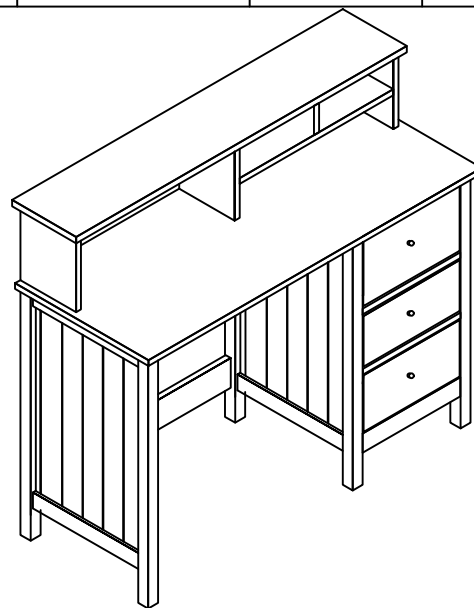

EXAMPLE FOR SKETCH ONLY

MADE IN MALAYSIA

ASSEMBLY INSTRUCTION

LV-2016-186 DESK&HUTCH

Thank you for purchasing this quality product. Be sure to check all packing material carefully for small parts that may have come loose inside the carton during shipment.

STEP 1

JOIN ALL THE HUTCH SHELF, PANEL AND DIVIDER BY USING DOWELS.

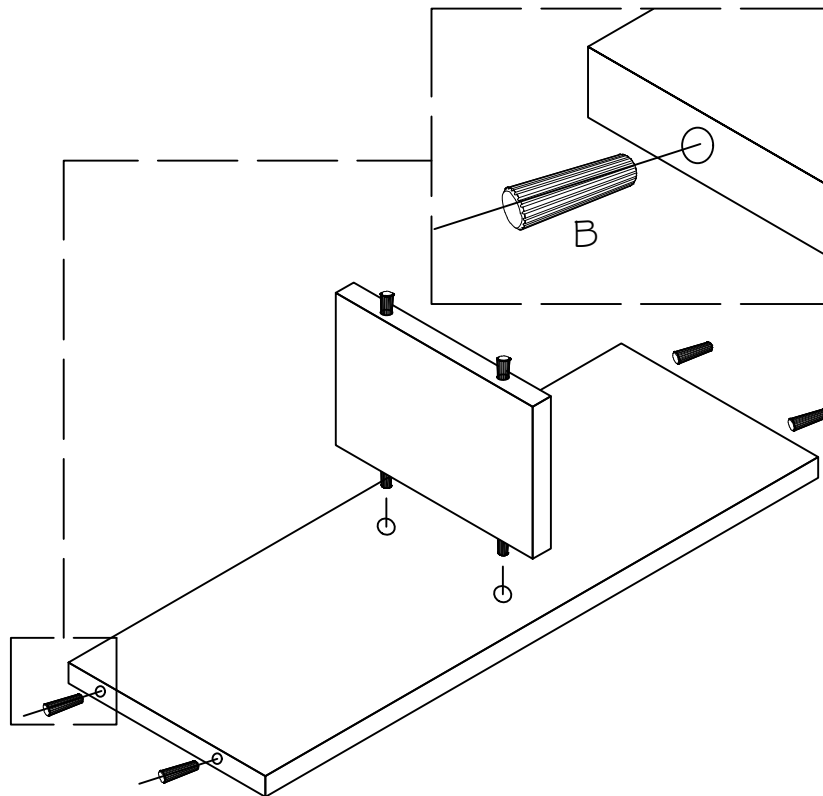

STEP 2

JOIN THE SHORT STRIP AND LONG STRIP AT THE BACK OF THE HUTCH BY USING DOWELS.

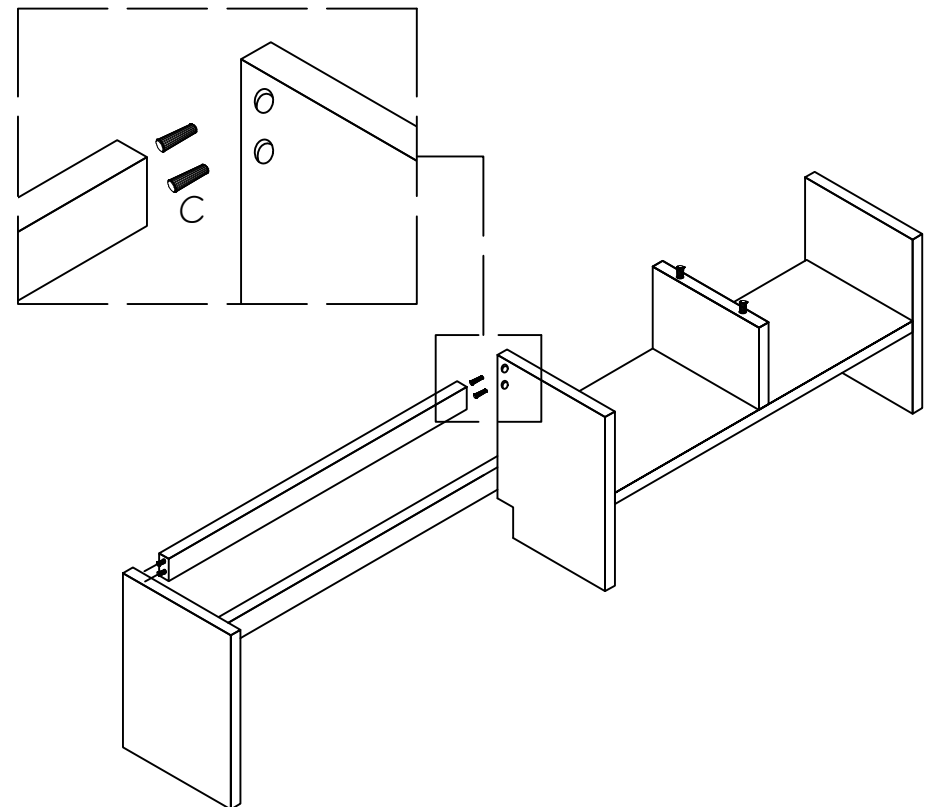

EXAMPLE FOR SKETCH ONLY

MADE IN MALAYSIA

ASSEMBLY INSTRUCTION

LV-2016-186 DESK&HUTCH

Thank you for purchasing this quality product. Be sure to check all packing material carefully for small parts that may have come loose inside the carton during shipment.

STEP 3

PUT IN THE MINIFIX SCREW INTO THE TOP OF THE HUTCH.

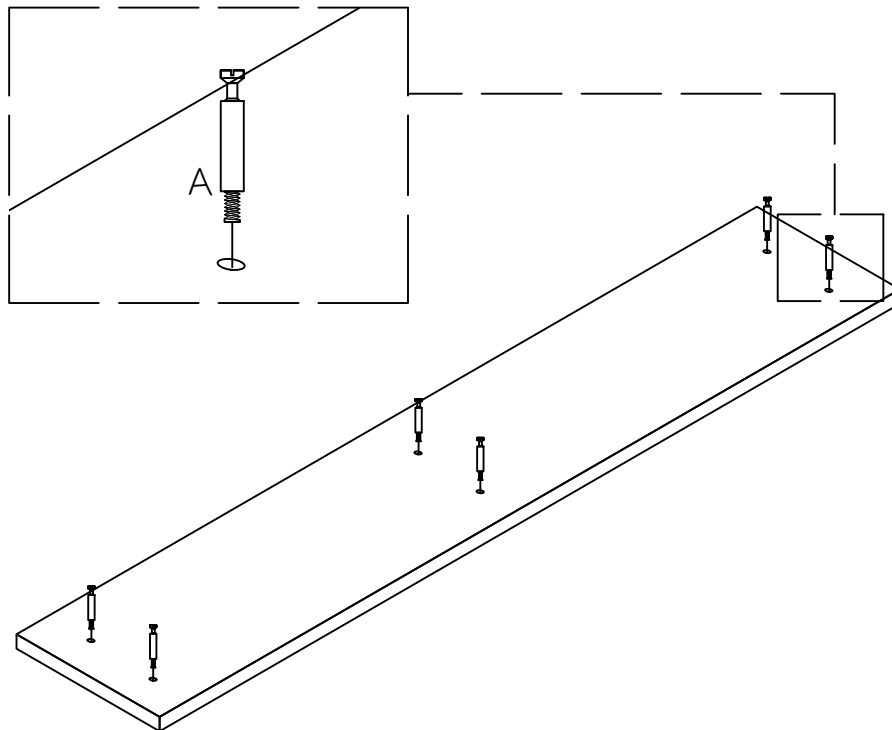

STEP 4

TIGHTEN THE MINIFIX SCREW ON THE SIDE OF PANEL TO ASSEMBLE THE TOP.

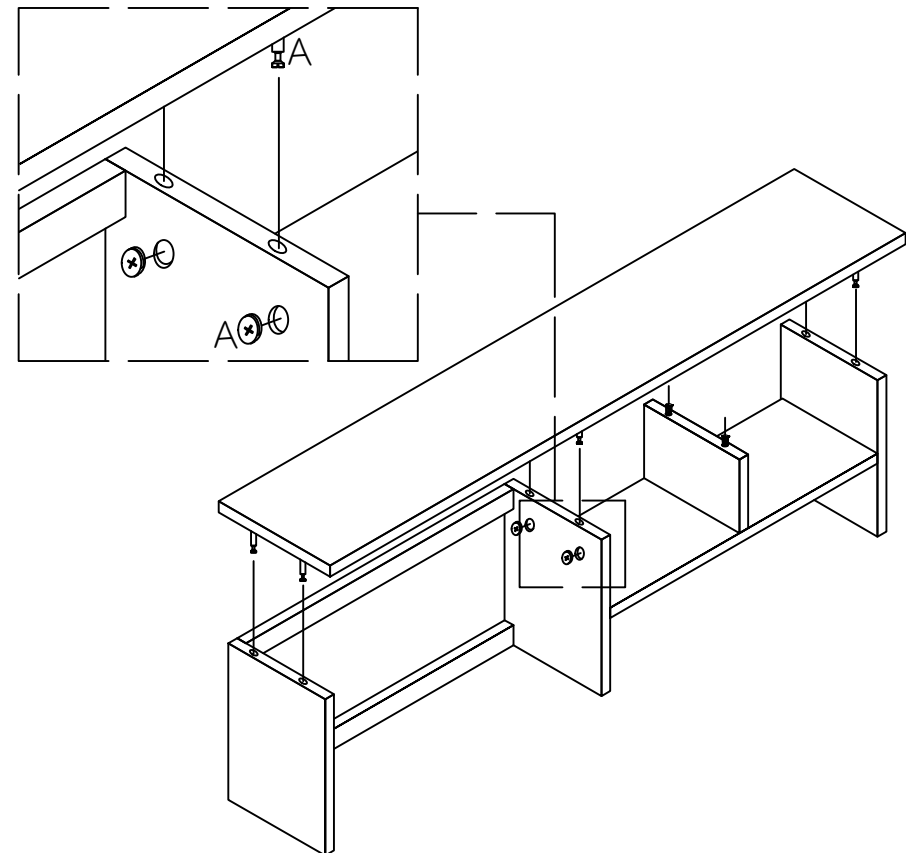

EXAMPLE FOR SKETCH ONLY

MADE IN MALAYSIA

ASSEMBLY INSTRUCTION

LV-2016-186 DESK&HUTCH

Thank you for purchasing this quality product. Be sure to check all packing material carefully for small parts that may have come loose inside the carton during shipment.

STEP 5

COVER THE BACK OF HUTCH WITH BACK PANEL BY USING CSK SCREW.

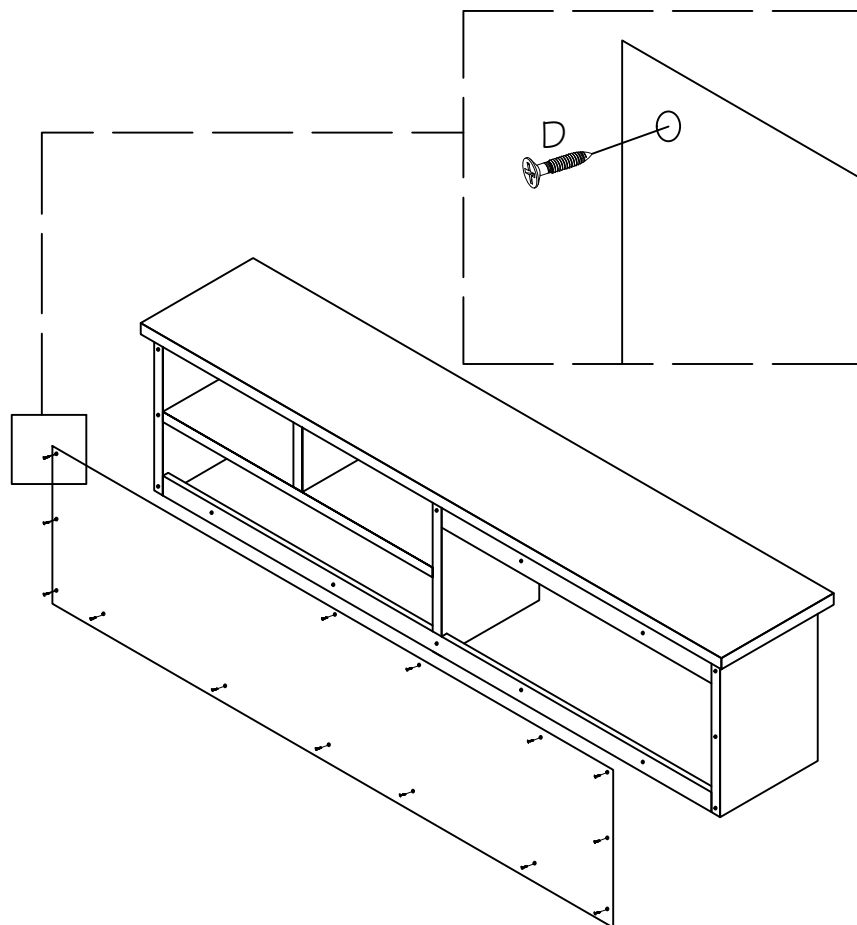

STEP 6

USE ALLEN KEY TO TIGHTEN THE JCBC SCREW FROM TOP OF DESK TO BOTTOM OF HUTCH PANEL.

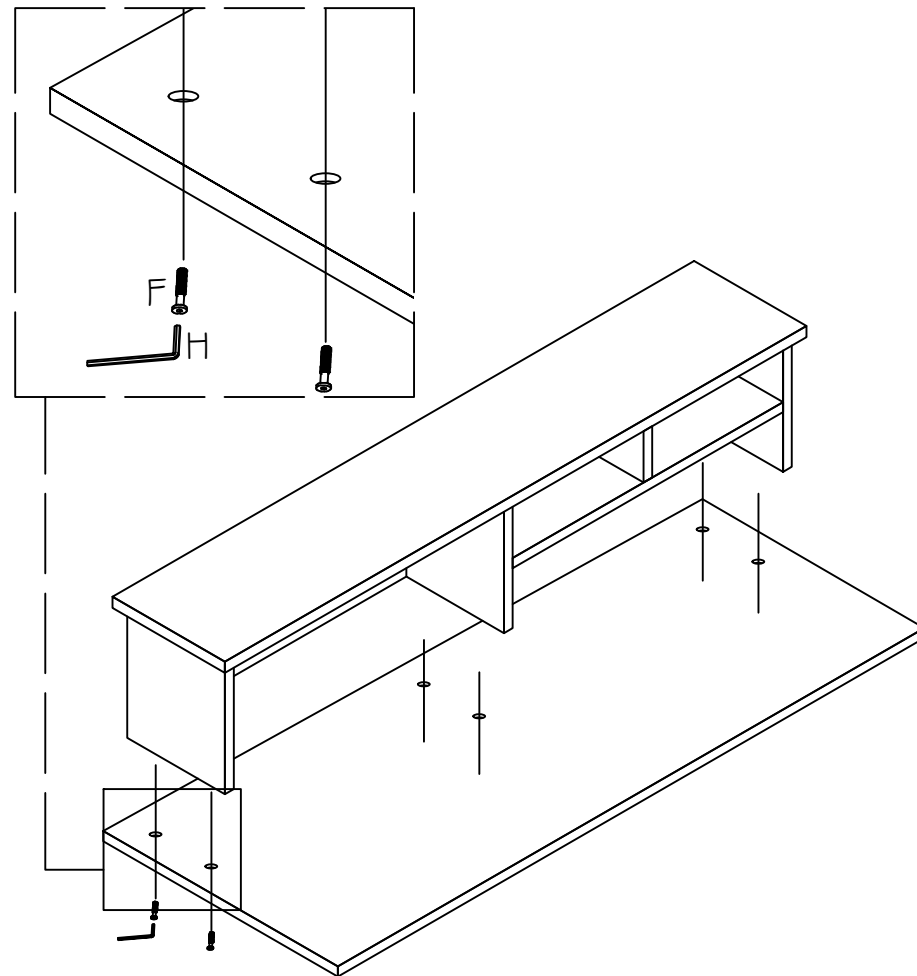

EXAMPLE FOR SKETCH ONLY

MADE IN MALAYSIA

ASSEMBLY INSTRUCTION

LV-2016-186 DESK&HUTCH

Thank you for purchasing this quality product. Be sure to check all packing material carefully for small parts that may have come loose inside the carton during shipment.

STEP 7

USE ALLEN KEY TO TIGHTEN THE JCBC SCREW FROM STRIP TO THE LEG OF DESK.

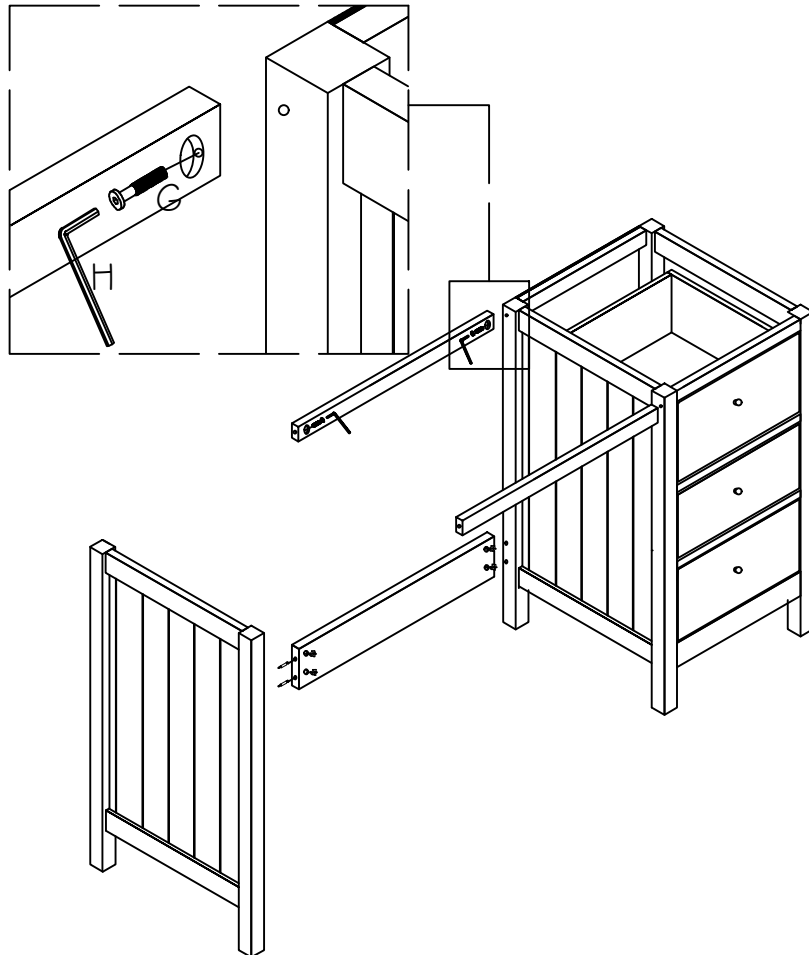

STEP 8

TIGHTEN THE MINIFIX SCREW ON THE DESK PANEL SUPPORT TO THE SIDE PANEL.

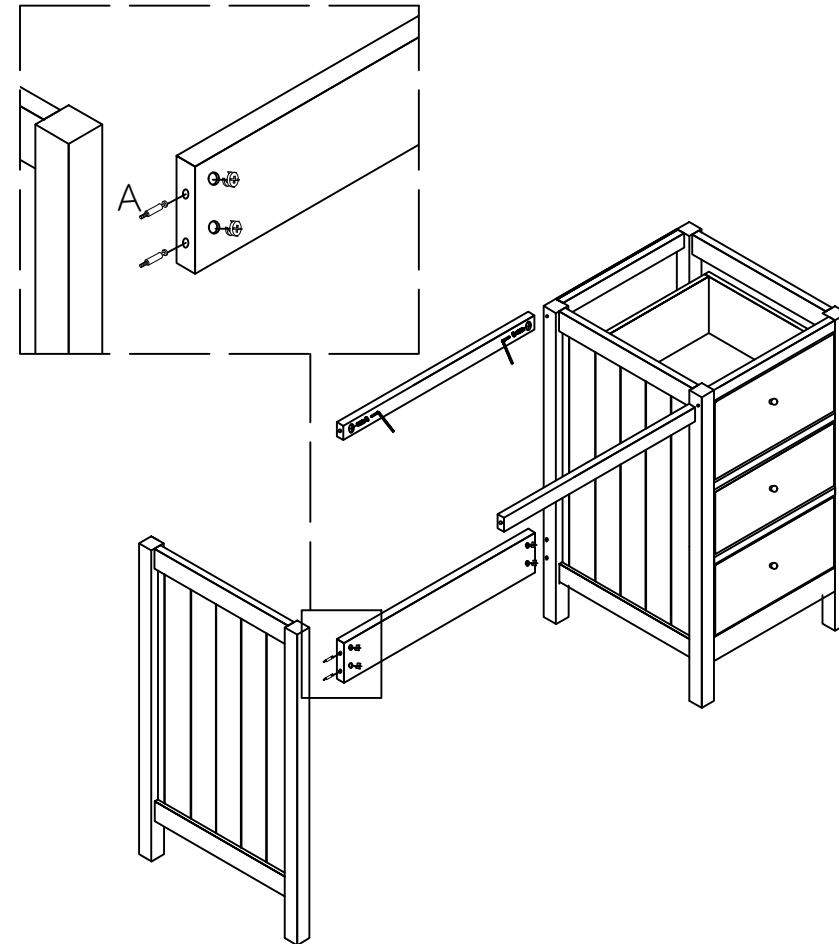

EXAMPLE FOR SKETCH ONLY

MADE IN MALAYSIA

ASSEMBLY INSTRUCTION

LV-2016-186 DESK&HUTCH

Thank you for purchasing this quality product. Be sure to check all packing material carefully for small parts that may have come loose inside the carton during shipment.

STEP 9

USE ALLEN KEY TO TIGHTEN THE JCBC SCREW FROM INTERNAL STRIPS TO TOP PANEL OF THE DESK.

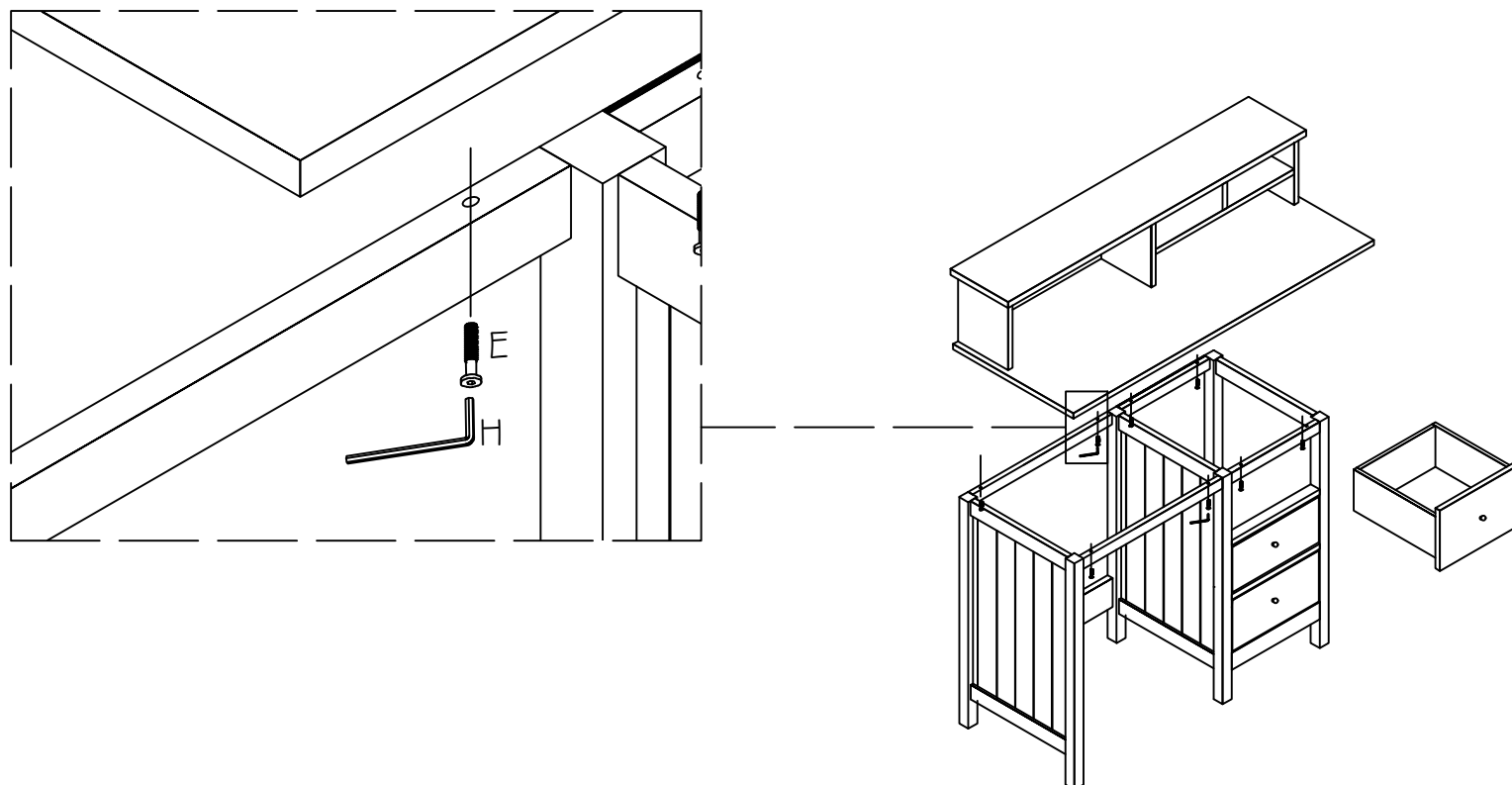

EXAMPLE FOR SKETCH ONLY

MADE IN MALAYSIA

ASSEMBLY INSTRUCTION

LV-2016-186 DESK&HUTCH

Thank you for purchasing this quality product. Be sure to check all packing material carefully for small parts that may have come loose inside the carton during shipment.

STEP 10

COVER THE BACK OF DRAWER WITH BACK PANEL BY USING CSK SCREW.

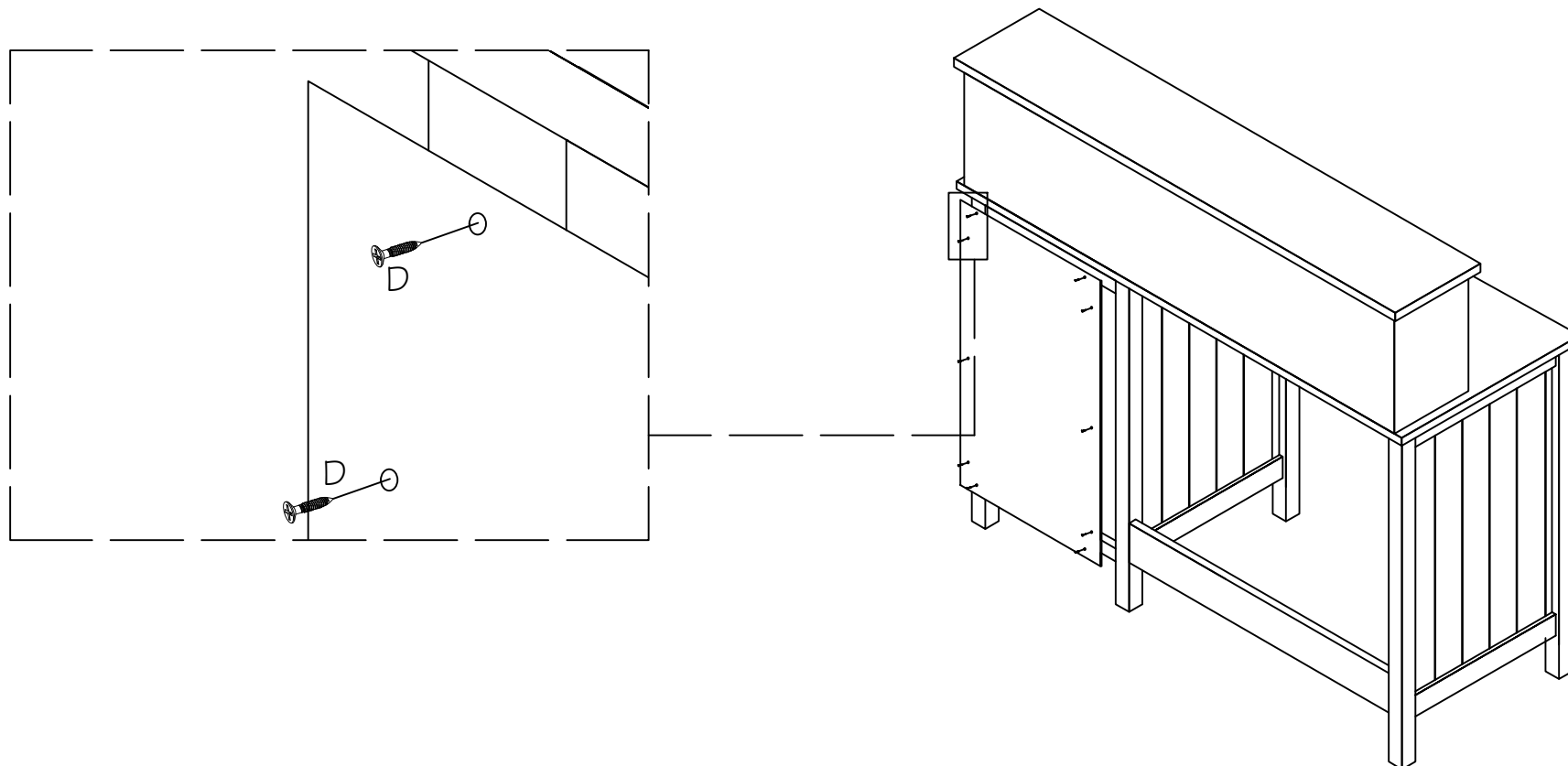

EXAMPLE FOR SKETCH ONLY

MADE IN MALAYSIA