

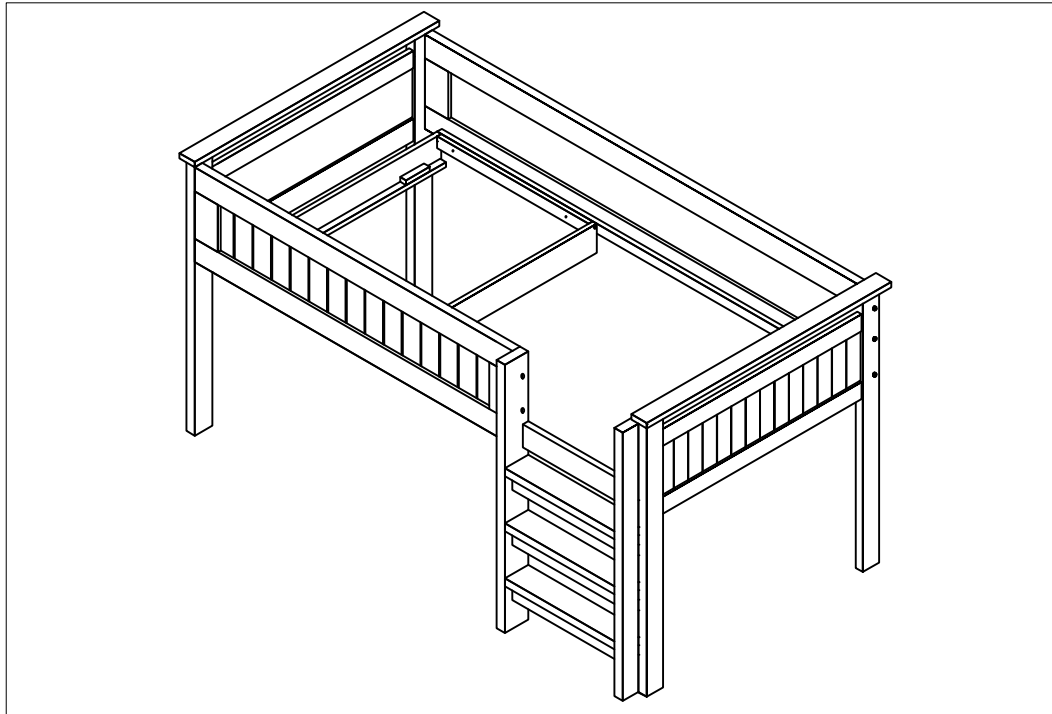





ASSEMBLY INSTRUCTION



LV-2016-186 MINI SLEEPER

Thank you for purchasing this quality product. Be sure to check all packing material carefully for small parts that may have come loose inside the carton during shipment.



HARDWARE LISTS

NO	DESCRIPTION	QTY
A	 Csk screw 4x30mm	4
B	 JCBC M6 X50mm	9
C	 JCBC M6 X30mm	7
D	 M4	1
E	 PLASTIC CAP	15

NO	DESCRIPTION	QTY
F	 BARREL NUT M6	12
G	 JCBC M6 X40mm	3

COMPONENT LISTS

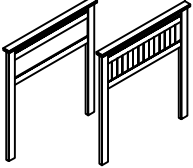
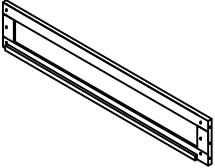
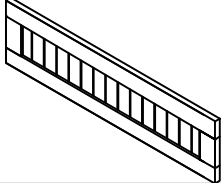
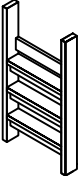
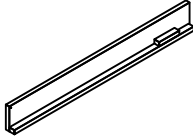
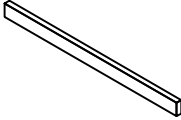
NO	DESCRIPTION	QTY
1	 HEADBOARD & FOOTBOARD	2
2	 SIDE RAIL (LEFT)	1
3	 SIDE RAIL (RIGHT)	1
4	 LADDER	1
5	 SIDE PANEL TRACK	2
6	 STRIP	2

EXAMPLE FOR SKETCH ONLY

MADE IN MALAYSIA

ASSEMBLY INSTRUCTION

LV-2016-186 MINI SLEEPER

Thank you for purchasing this quality product. Be sure to check all packing material carefully for small parts that may have come loose inside the carton during shipment.

STEP 1

SET UP THE SIDE RAIL (LEFT) TO THE HEADBOARD AND FOOTBOARD WITH JCBC SCREW AND BARREL NUT BY USING ALLEN KEY. COVER THE HOLE WITH PLASTIC CAP PROVIDED.

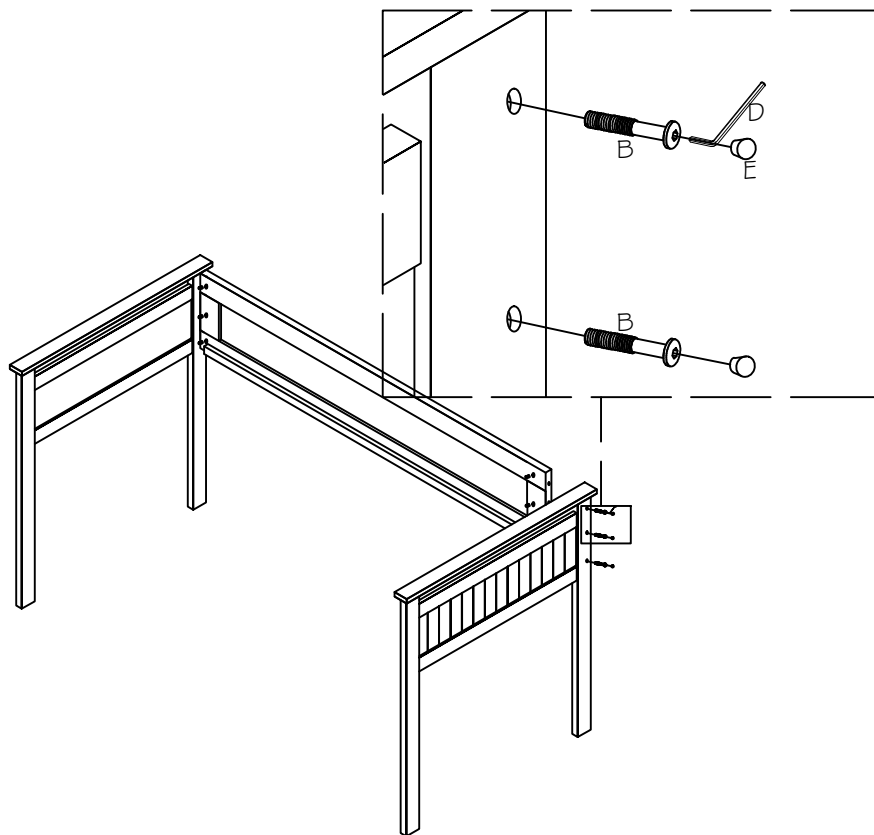

STEP 2

ATTACH LADDER TO THE FOOTBOARD WITH JCBC SCREW BY USING ALLEN KEY. COVER THE HOLE WITH PLASTIC CAP PROVIDED.

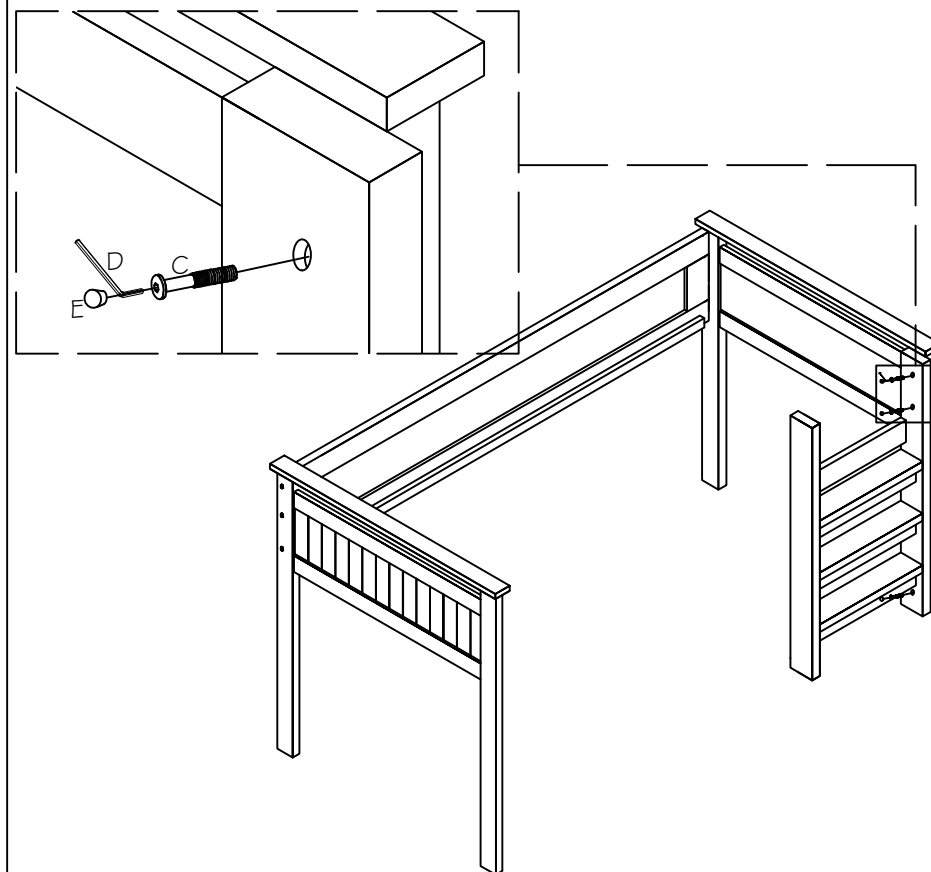

EXAMPLE FOR SKETCH ONLY

MADE IN MALAYSIA

ASSEMBLY INSTRUCTION

LV-2016-186 MINI SLEEPER

Thank you for purchasing this quality product. Be sure to check all packing material carefully for small parts that may have come loose inside the carton during shipment.

STEP 3

SET UP THE SIDE RAIL(RIGHT) TO THE HEADBOARD AND LADDER WITH JCBC SCREW AND BARREL NUT BY USING ALLEN KEY. COVER THE HOLE WITH PLASTIC CAP PROVIDED.

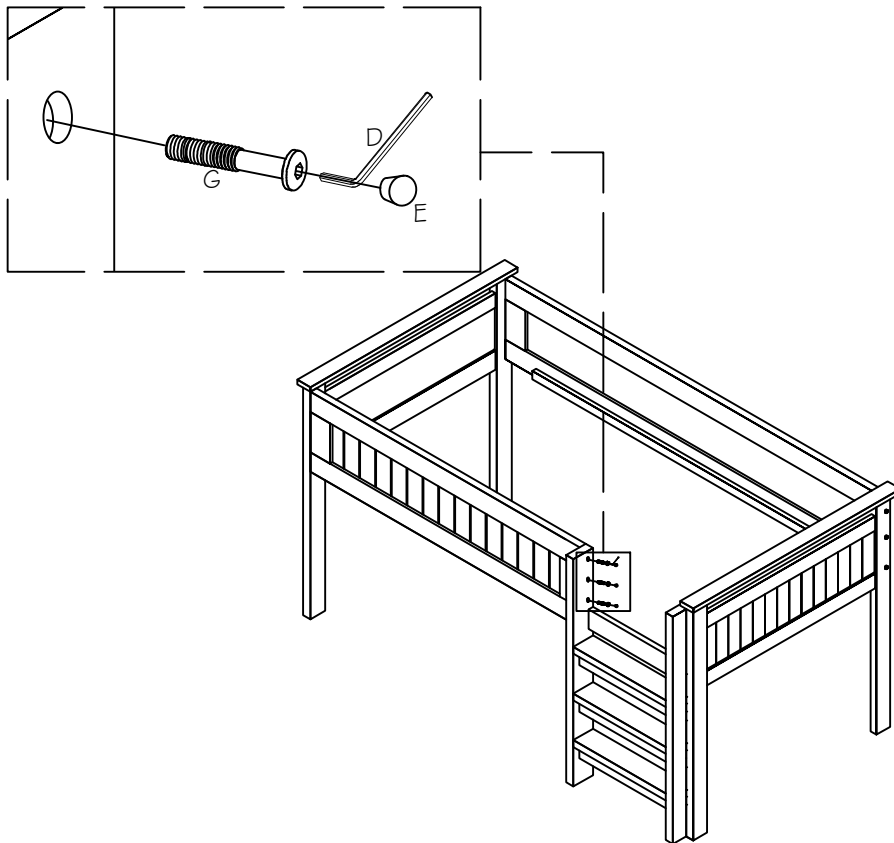

STEP 4

ATTACH THE SIDE PANEL TRACK TO THE STRIP WITH JCBC SCREW.

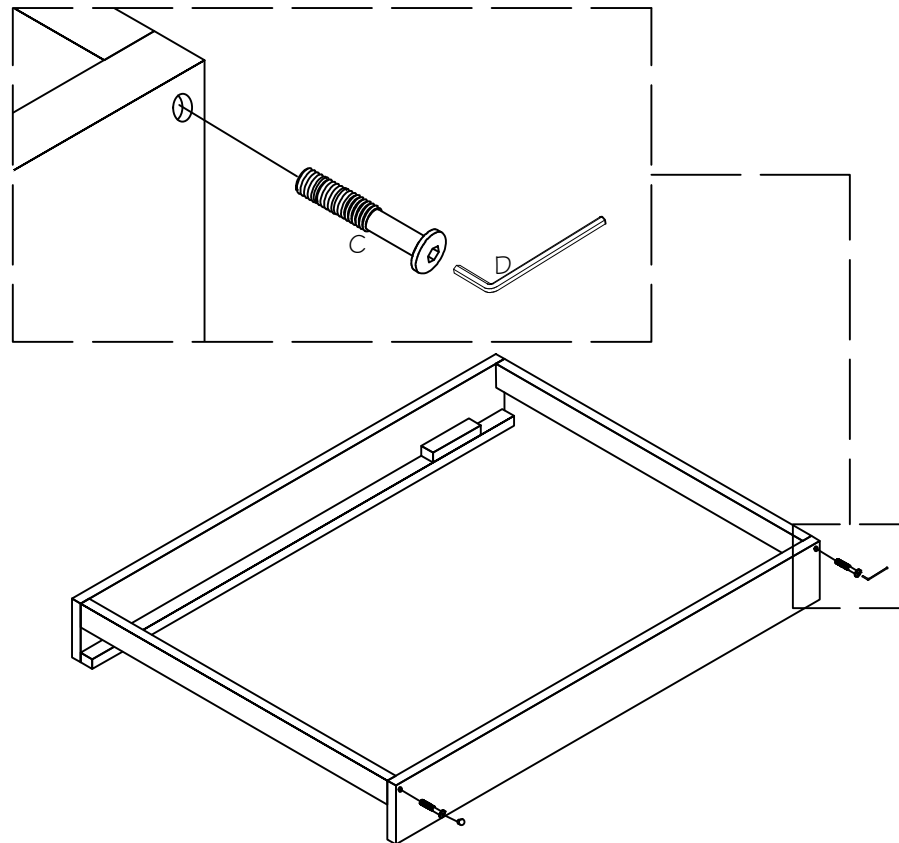

EXAMPLE FOR SKETCH ONLY

MADE IN MALAYSIA

ASSEMBLY INSTRUCTION

LV-2016-186 MINI SLEEPER

Thank you for purchasing this quality product. Be sure to check all packing material carefully for small parts that may have come loose inside the carton during shipment.

STEP 5

ATTACH THE ROLLER TRACK TO SIDE RAIL SUPPORT WITH CSK SCREW.

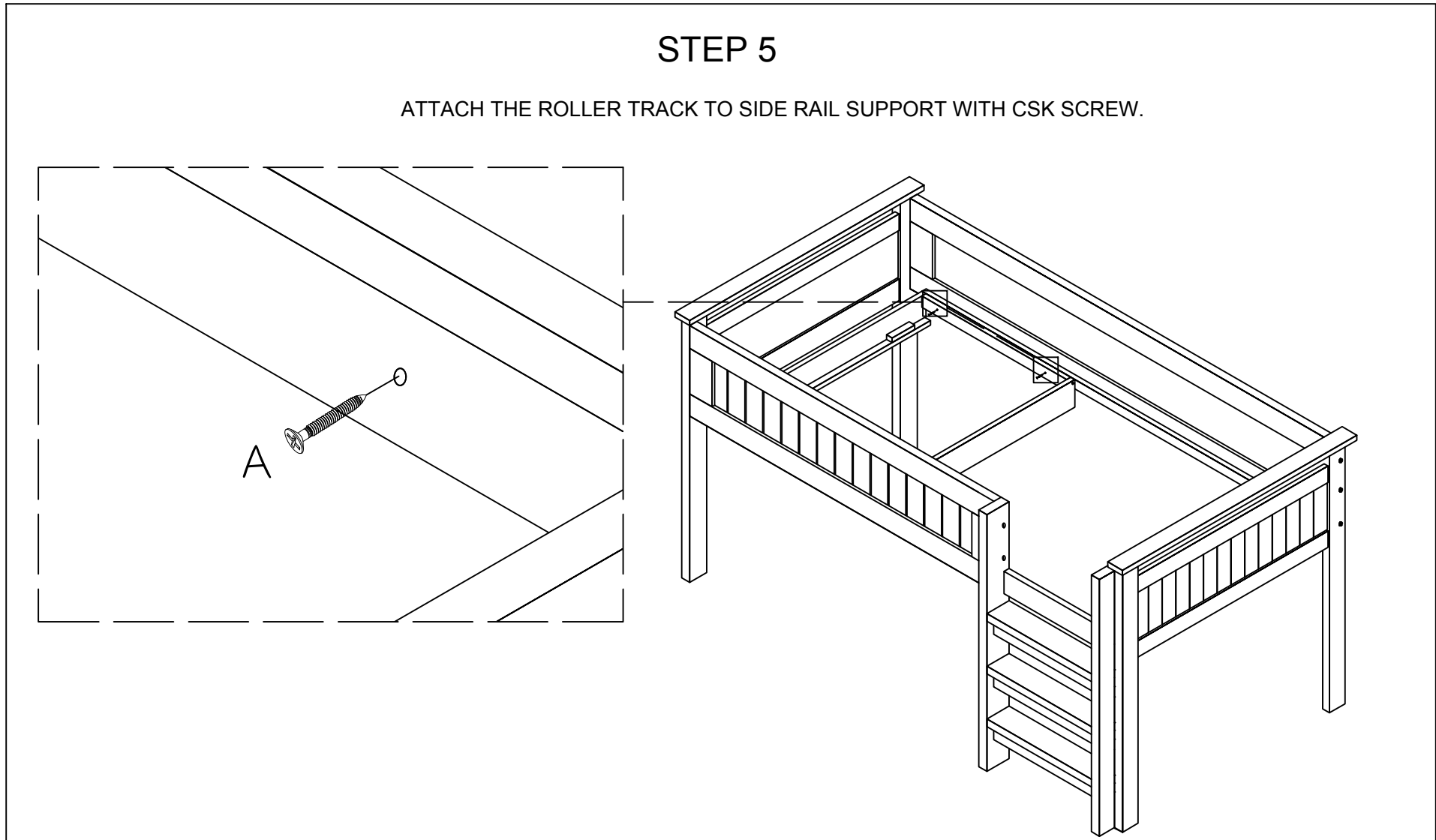

EXAMPLE FOR SKETCH ONLY

MADE IN MALAYSIA