

ASSEMBLY INSTRUCTION

LV-2016-186-TRUNDLE BED

Thank you for purchasing this quality product. Be sure to check all packing material carefully for small parts that may have come loose inside the carton during shipment.

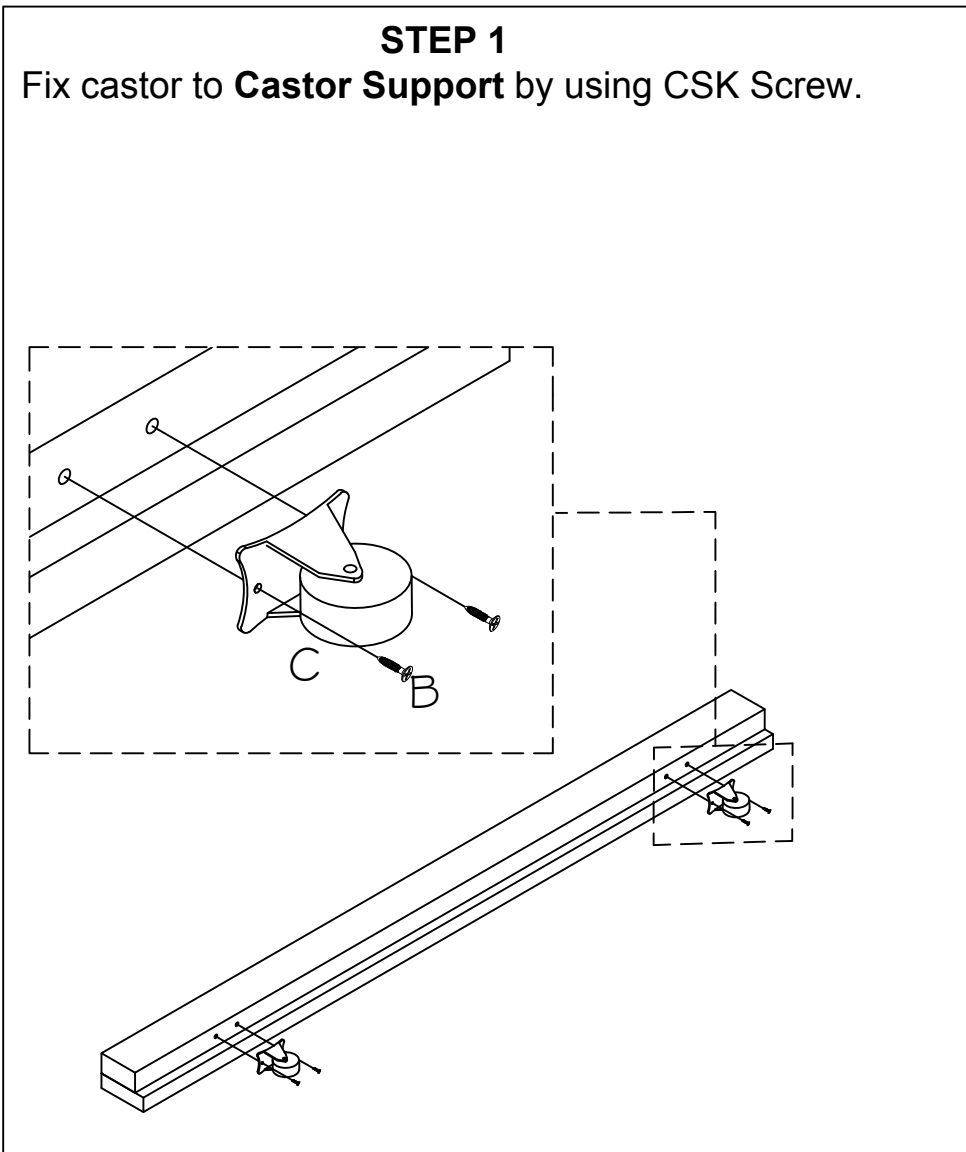
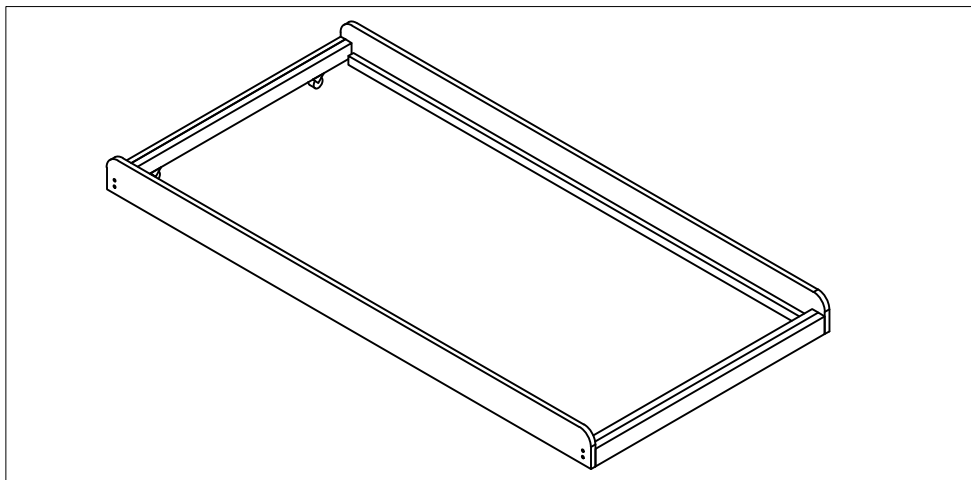

HARDWARE LISTS

NO	DESCRIPTION	QTY	NO	DESCRIPTION	QTY
A	JCBC Ø6 x 35mm	8	D	Allen Key M4	1
B	CSK Screw Ø3.5 x 16mm	8	E	Plastic Cap	8
C	Castor	4	F	DOWEL Ø8X30MM	8

COMPONENT LISTS

NO	DESCRIPTION	QTY	NO	DESCRIPTION	QTY
1	Side Rail	2	2	Castor Support	2

EXAMPLE FOR SKETCH ONLY

MADE IN MALAYSIA

STEP 2

Fix up the given dowel and use allen key to tighten JCBC screws from **Side Rail** to **Castor Support** until the JCBC screws are totally in.

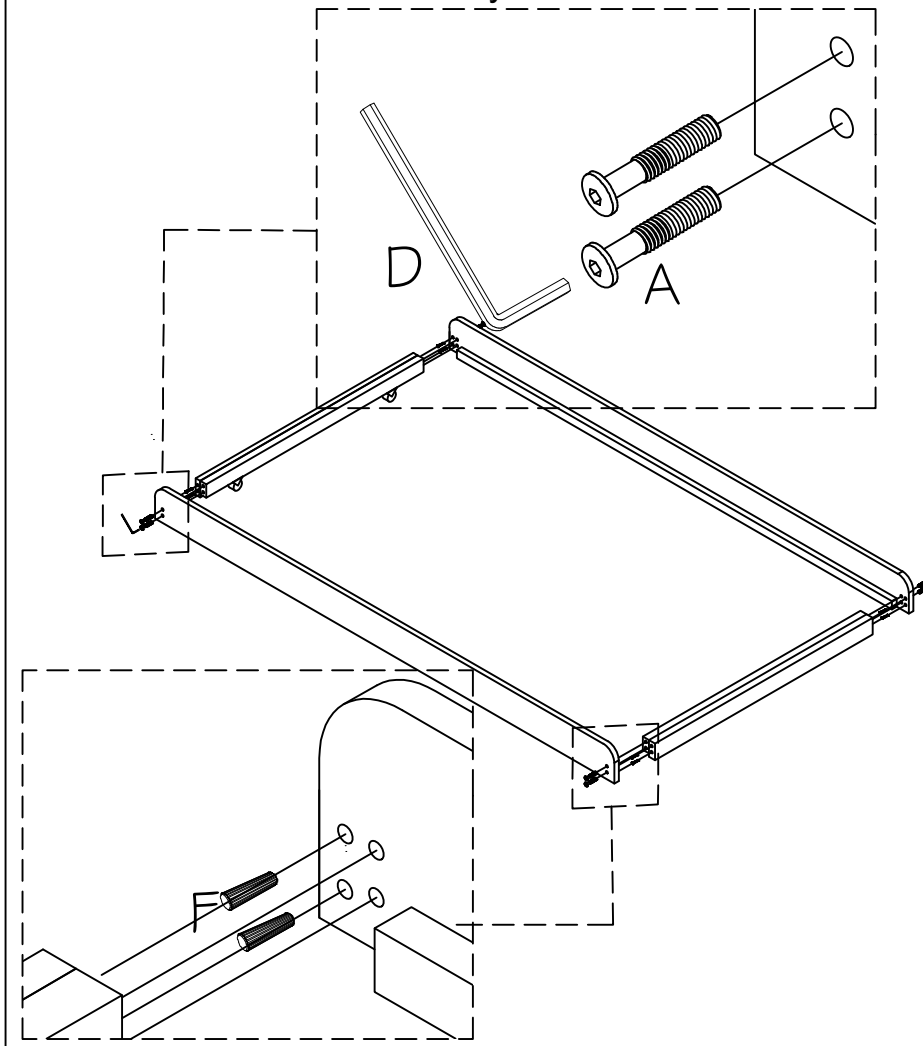

STEP 3

Cover JCBC holes by using plastic cap.

