

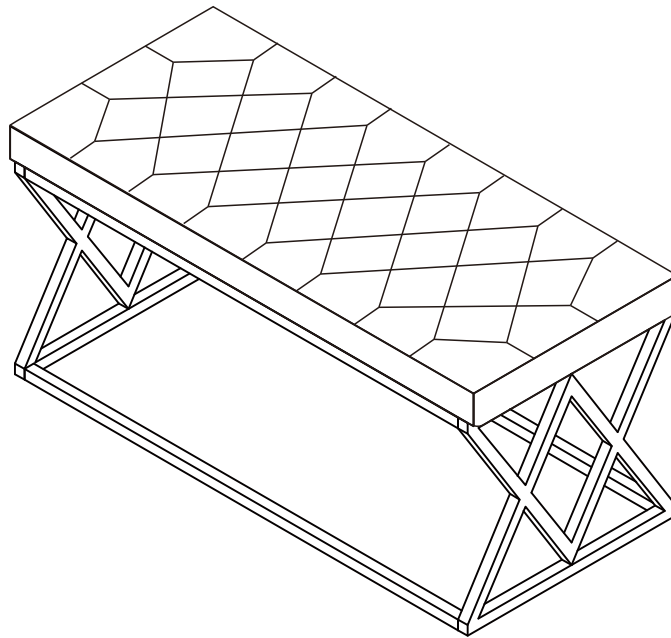

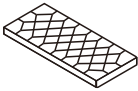

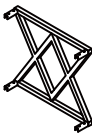

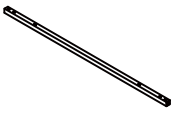

ANNABEL BENCH ASSEMBLY INSTRUCTIONS

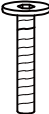

<p>a</p>  <p>1 x Seat</p>	<p>b</p>  <p>2 x Legs</p>	<p>c</p>  <p>2 x Link Tube</p>	<p>d</p>  <p>2 x Link Tube</p>	<p>e</p>  <p>16 x Screw M6X10MM</p>
<p>f</p>  <p>1 x Tool</p>	<p>g</p>  <p>4 x Screw M6X35MM</p>	<p>h</p>  <p>4 x Steel Pad Ring</p>		

STOP!

Before you start...

1



Read Instructions carefully.

2

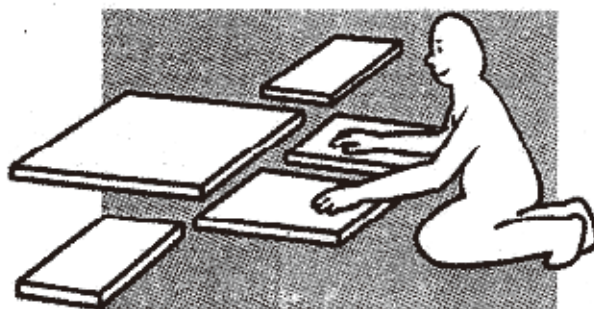

Lay out all of the components on a soft surface as if you were preparing to do a jigsaw puzzle.

3



Carefully identify each component, especially those that are similar. The most common mistake is getting things back to front.

4



Separate and identify each component from the hardware pack— and rest each one in its proper location before fastening.

5

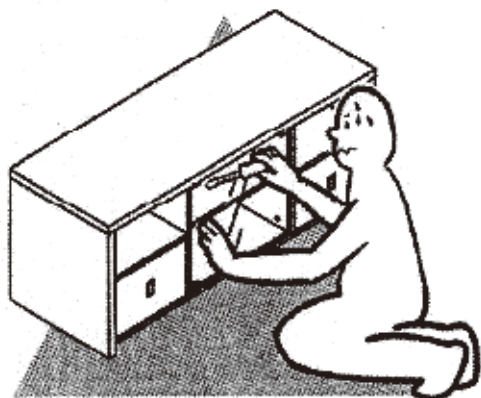

DO NOT Over-tighten screws

6



DO NOT set glue until you are certain that the parts belong together.

Step:1

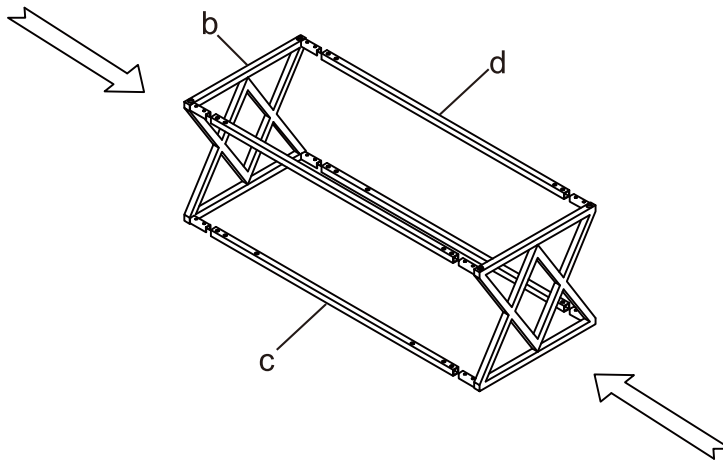
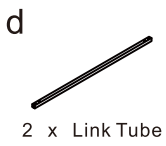
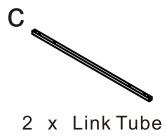
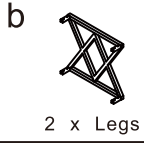

Step:2

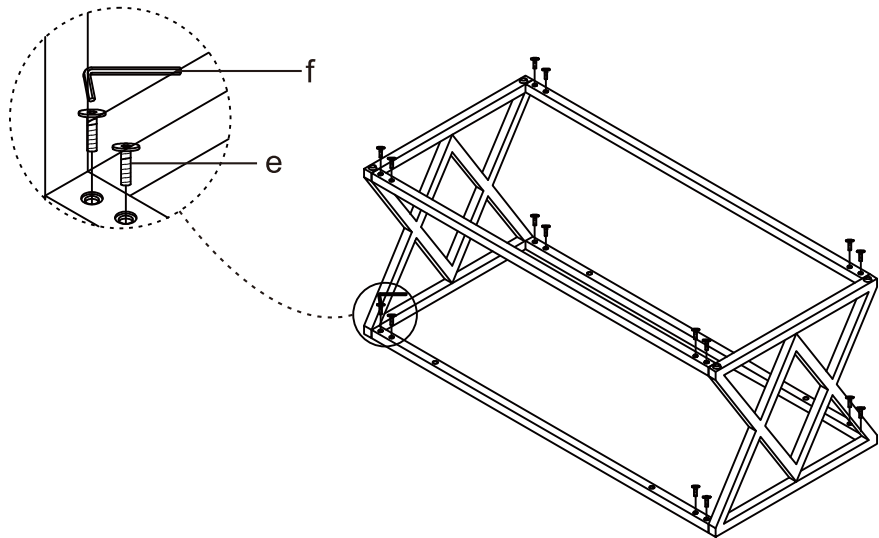
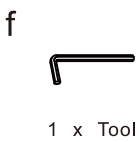
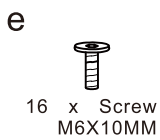

Step:3

