

ASSEMBLY INSTRUCTION

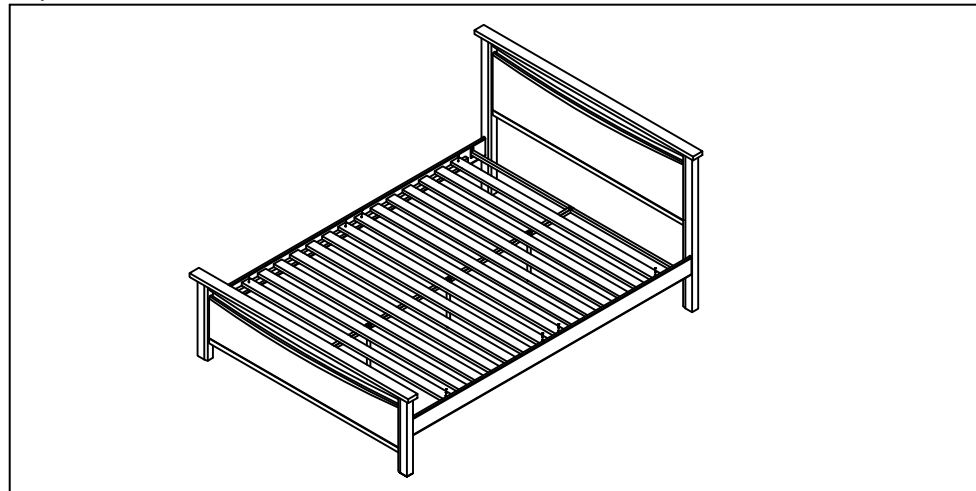



LV-2016-185 Double/Queen/King Bed



Thank you for purchasing this quality product. Be sure to check all packing material carefully for small parts that may have come loose inside the carton during shipment.

COMPONENT LISTS





HARDWARE LISTS

NO	DESCRIPTION	QTY
A	 JCBB Ø8 x 25mm	12
B	 JCBB Ø6 x 15mm	8
C	 JCBC Ø6 x 30mm	2
D	 JCBB** Ø8 x 40mm	3

NO	DESCRIPTION	QTY
E	 CSK Screw Ø4 x 38mm	16
F	 Allen Key M4	1
G	 Allen Key M5	1

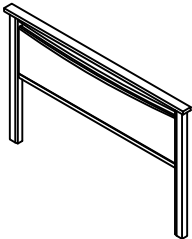
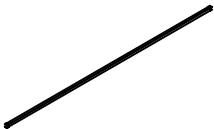
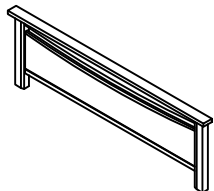
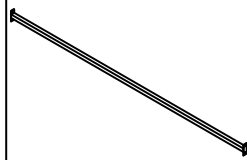
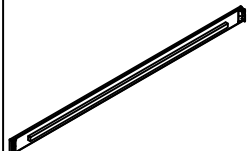
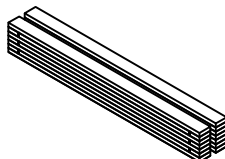
*JCBB assembled on third legs.

NO	DESCRIPTION	QTY	NO	DESCRIPTION	QTY
1	 Headboard	1	5	 Centre rail	1
2	 Footboard	1	6	 Cross bar	2
3	 Side rail	2	7	 Slat base	14
4	 Third leg	3			

EXAMPLE FOR SKETCH ONLY

MADE IN MALAYSIA

STEP 1

Pre-screw JCBB screw into position on Headboard and Footboard legs as shown. Hook the side rail to the JCBB screws and fix the centre JCBB screw as shown. Use allen key to tighten the JCBB screw until totally in.

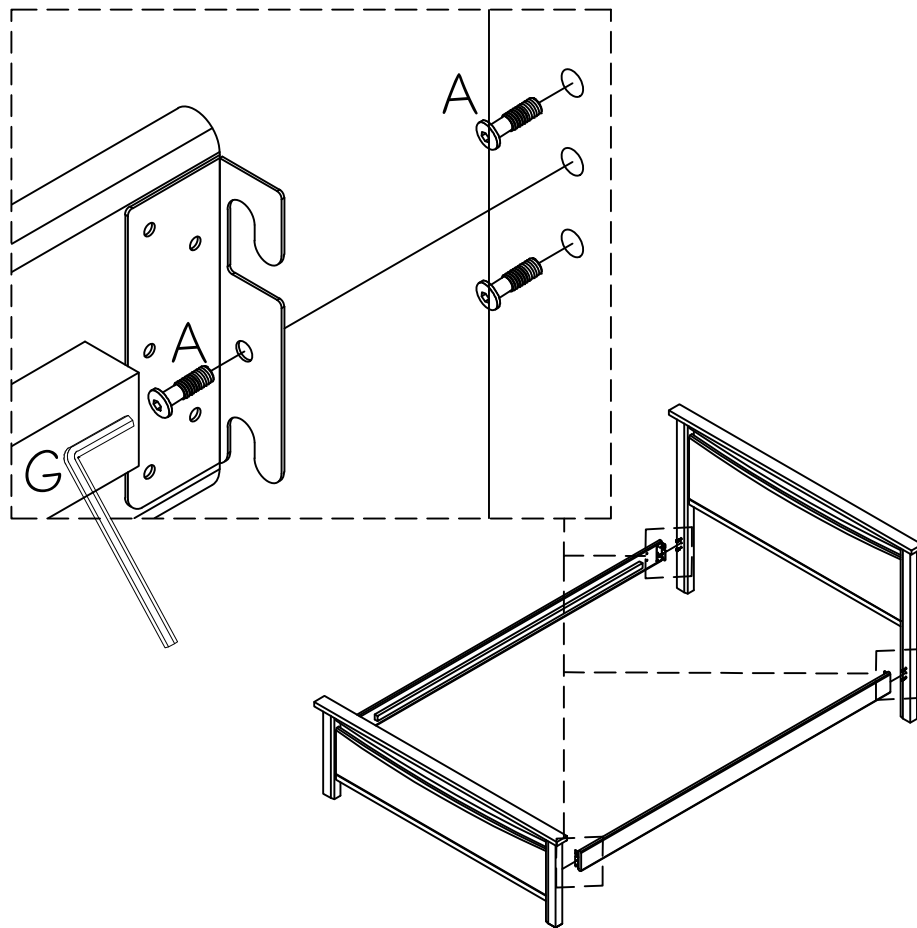

STEP 2

Place the cross bar at front and back in between the Side Rail as shown. Use allen key to tighten the JCBC screws from cross bar to Side Rail until the screws are totally in.

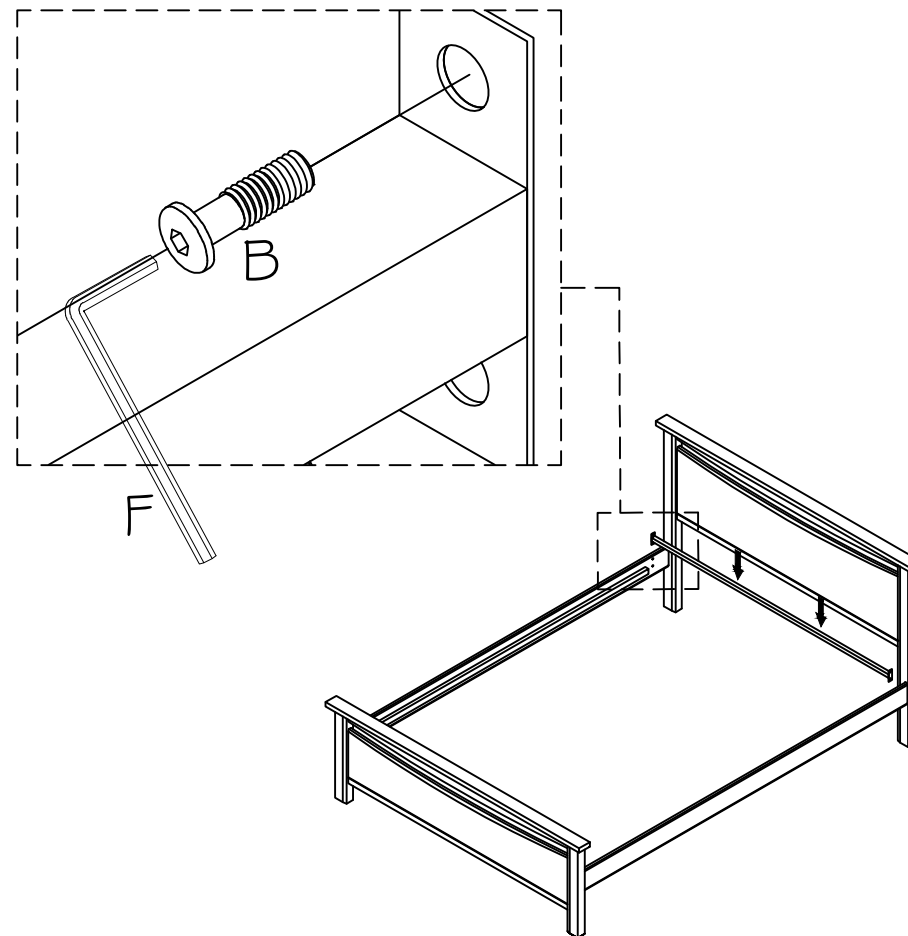

STEP 3

Place centre rail as shown. Use allen key to tighten the JCBC Screws from Centre Rail to Cross bar until the Screws are totally in.

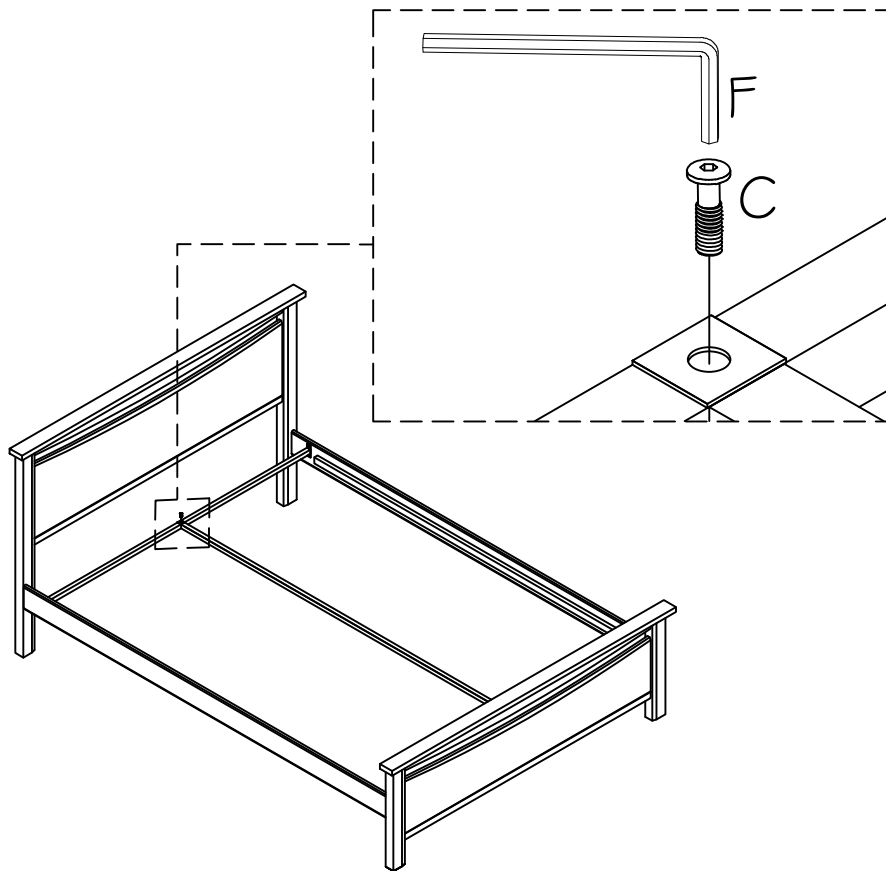

STEP 4

Detach the assembled caps and JCBB Screws from Third Leg. Fix the third leg as shown and use allen key to tighten the JCBB screws until they are totally in.

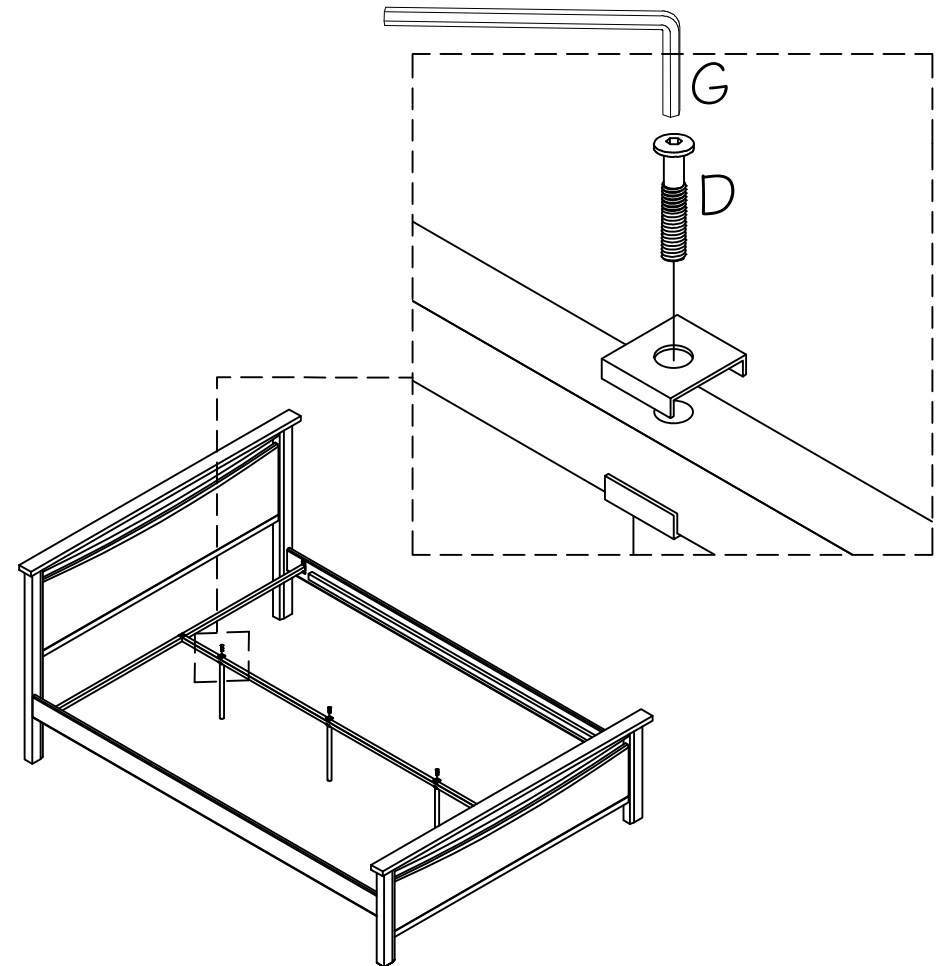

STEP 5

Place Slat Base on Side Rail Support and fix CSK Screws at the holes as shown.

