

ASSEMBLY INSTRUCTIONS

MODEL: B6077 ASTORIA CHEST

Thank you for purchasing this quality product. Be sure to check all packing material carefully for small parts which may have come loose inside the carton during shipment. Identify and count all parts and compare with hardware list as below:

STEP 1

(BOX 1) BOX OF CHEST		
ITEM	DRAWING	DESCRIPTION
A		CHEST
B		BOTTOM LEG (FRONT)
C		BOTTOM LEG (BACK)

(BOX 1) BOX OF CHEST (HARDWARE LIST)				
ITEM	DRAWING	DESCRIPTION	DIMENSION	QTY
D		JCBB (M8) WITH WASHER	8 x P1.0 x 35MM	4
E		WD (M10)	8 x 30MM	8
F		ALLEN KEY M5	5 x 35 x 55MM	1

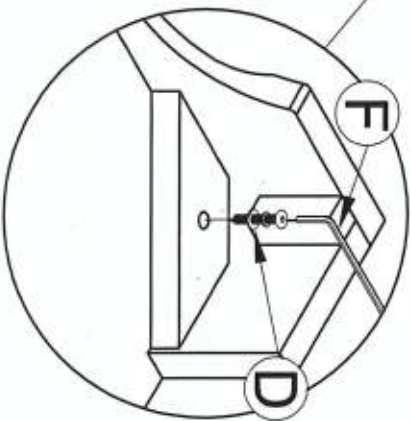
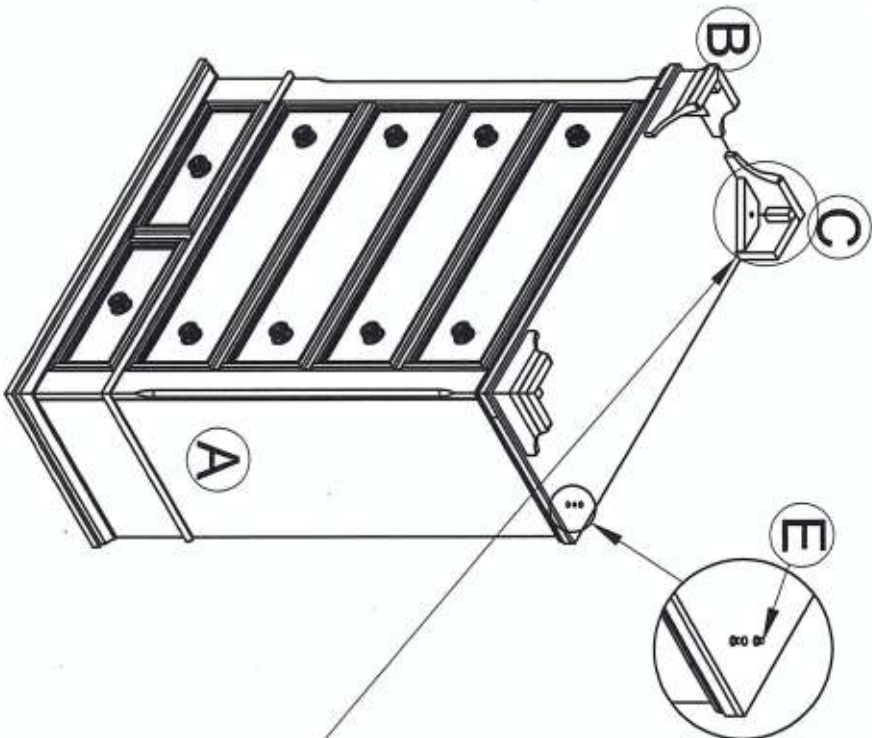

Step 1: Attach and tighten the CHEST bottom leg (B) & (C) to the bottom frame insert WD (E) and JCBB (D) With Washer as shown.

NOTE: MUST TIGHTEN SCREW PERIODICALLY WITH USE. SCREWS WILL BECOME LOOSE. CHECK TIGHT OF ALL SCREWS EVERY 6-8 WEEKS. CLEANING INSTRUCTION

After assembled, clean & polish the complete parts if necessary with soft cloth and household recognized furniture polish.

THE ANTI TIPPING HARDWARE IS LOCATED IN THE CHEST BACK

THE HARDWARE IS LOCATED IN THE PACKING ITEMS

MADE IN MALAYSIA