

ASSEMBLY INSTRUCTION

DESCRIPTION: Type 10 BABY BOOM

2.5 hrs

APPROXIMATE ASSEMBLY TIME
EXCLUDING GLUE SETTING TIME

2 PERSON ASSEMBLY



FLOOR AREA
2,5M X 2,5M

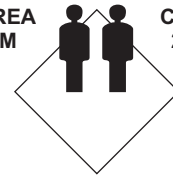

CEILING HEIGHT
2,0M

REQUIRED ASSEMBLY SPACE

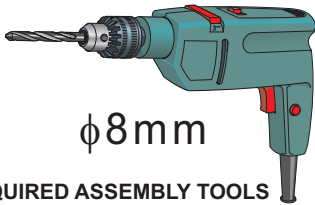

$\phi 8\text{mm}$

REQUIRED ASSEMBLY TOOLS

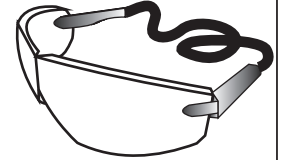
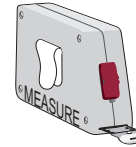
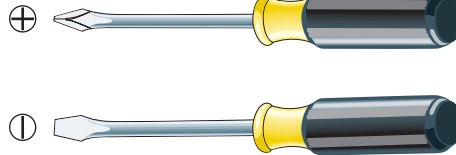

ASSEMBLED DIMENSIONS



PART LIST

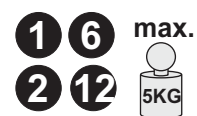
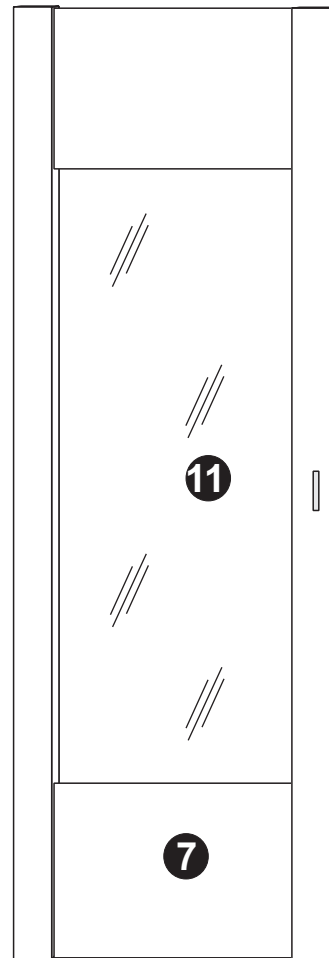
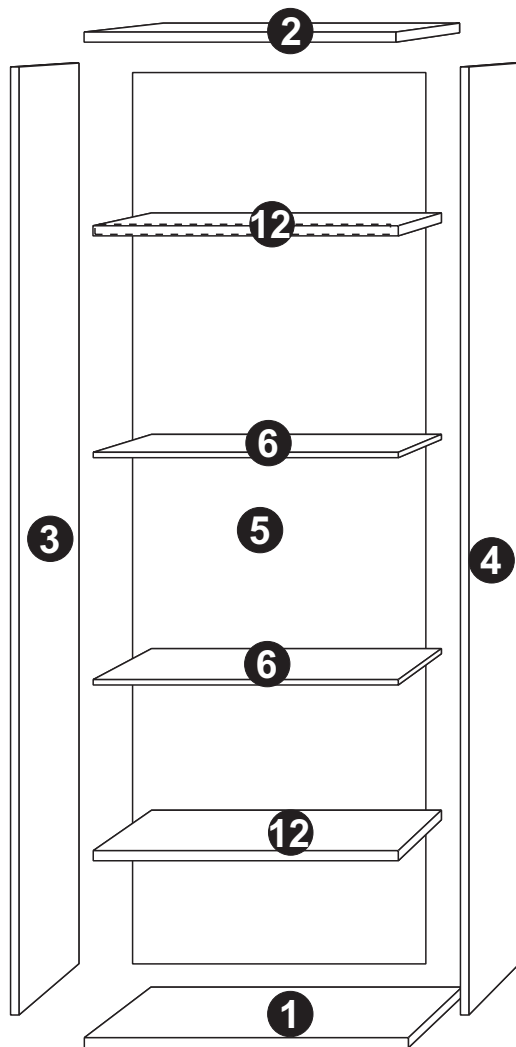





NO. PARTS LIST

QTY

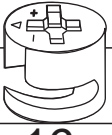
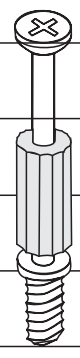

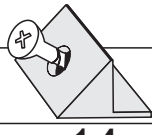
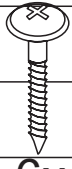
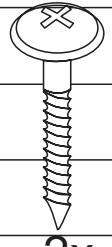
(1) BOTTOM PANEL	1
(2) TOP PANEL	1
(3) LEFT SIDE PANEL	1
(4) RIGHT SIDE PANEL	1
(5) BACK PANEL	1
(6) GLASS SHELF	2
(7) DOOR	1
(11) GLASS DOOR	1
(12) SHELF	2

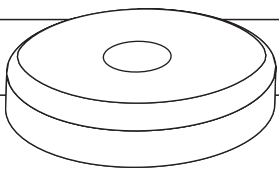
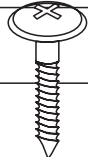
HARDWARE LIST

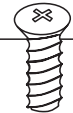
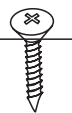
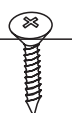
						
16x 15x12mm	16x	16x 8x28mm	18x	14x	6x 3x20mm	2x 4x30mm
A CAM LOCK	B CAM BOLT	C DOWEL	D CAM COVER	E SECURING BRACKET	F SCREW	F2 SCREW

					
4x	4x 4x22mm	2x	8x 6,3x13mm	8x 3,5x13mm	14x 3x16mm
G NYLON FOOT	G1 SCREW	H PEG	L1 GRUB SCREW	M. SCREW	N SCREW

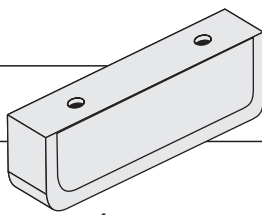
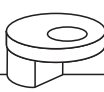
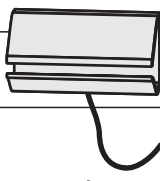

			
1x L-64	14x	1x	8x 5x16mm
O HANDLE	P. GRIP DOOR GLASS	R LED LIGHTS	Z1 SHELF GLASS SUPPORT

HARDWARE LIST

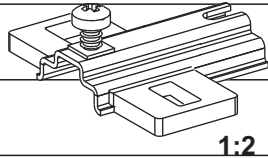

4x
H-2
V
HINGE PLATE

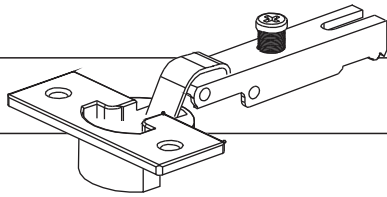

1:2
4x
kr0
W1
HINGE

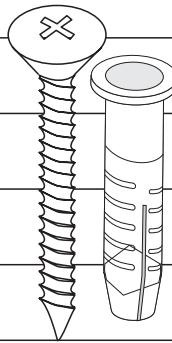

1x
4x35mm
R
PLASTIC
DOWEL

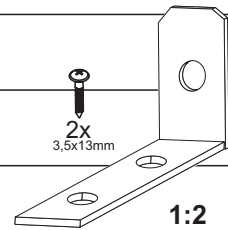

2x
3,5x13mm
1:2
1x
T
ANGLE



Top Tips before you start!

1. Please check that all parts are present before you start the assembly of your furniture, as once assembled, the furniture is exempt from our home approval policy.
2. For ease and speed of assembly, we recommend that before you commence each step of the assembly, that you identify all the parts required for that step.
3. For larger items, please ensure that you have sufficient space and people (as indicated on page 1) to assemble your product safely.
4. We recommend that, where possible, all items are assembled near to the area in which they will be placed in use, to avoid moving the product unnecessarily once assembled.
5. For the protection of your furniture, particularly items of high gloss finish, we recommend that the product is placed on a protected surface during assembly to prevent any damage.
6. During assembly please take care not to over-tighten any fittings, as this may damage the product .

Care and Maintenance of your Furniture

Please periodically check all fittings and re-tighten as necessary.

Please do not sit or stand on this item.

Never allow any kind of liquid to remain on your furniture. Absorption can cause wood to warp or finishes to de-laminate.

Please do not drag and pull your furniture.

SPECIAL TIPS FOR FITTING CAM-LOCKS AND CAM-PILLARS

CAM-LOCK

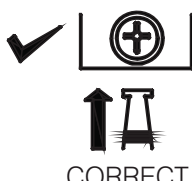
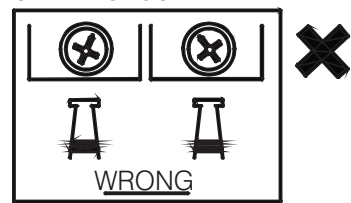

WHEN FITTING CAMS
ENSURE STARTING POSITION IS CORRECT
BEFORE YOU INSERT CONNECTING CAM-PILLAR
TURN CLOCKWISE UNTILE SECURE

Align with long point of cross

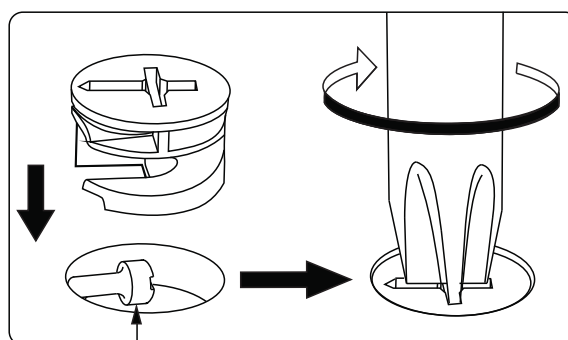

Pillar head needs to be in centre

CAM-PILLAR

Tighten until shoulder is flush with panel. Do not overtighten or undertighten (see example below)

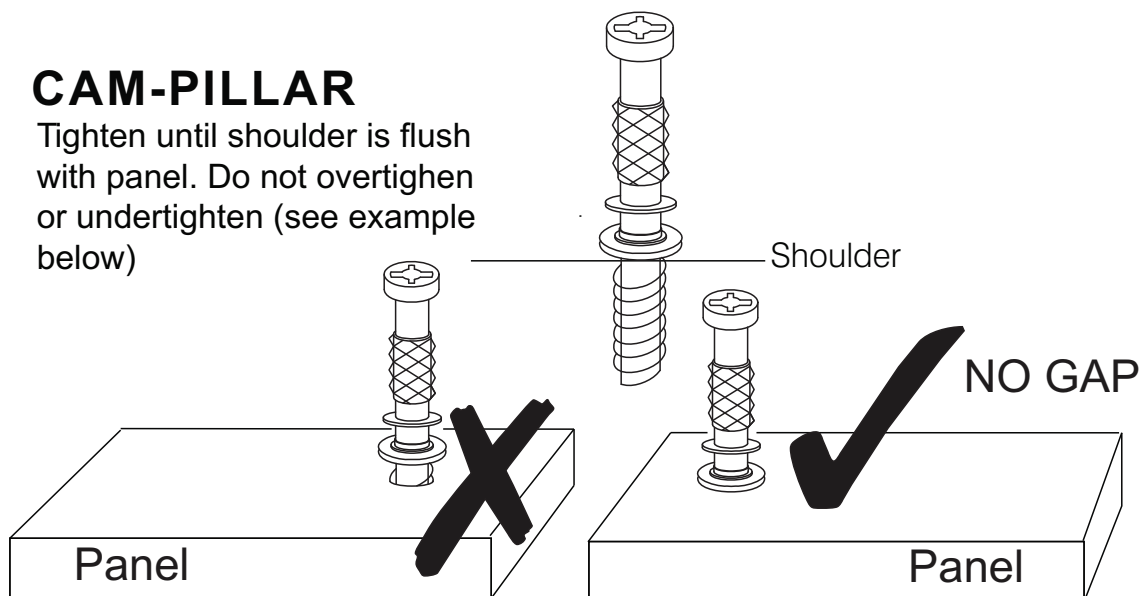

STEP 1

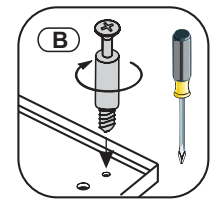
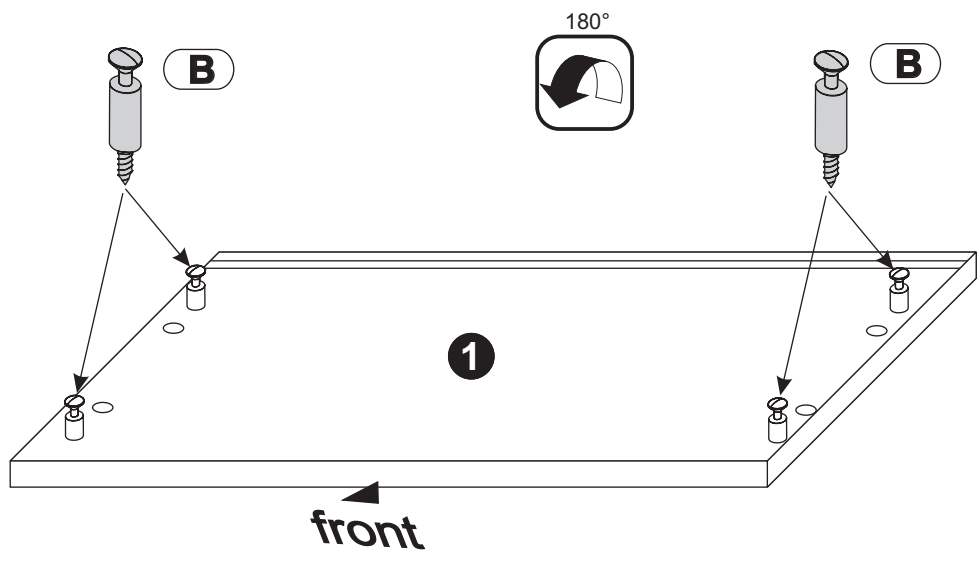
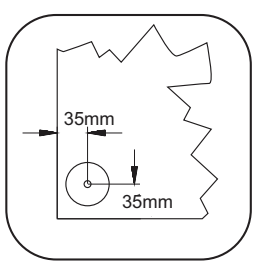
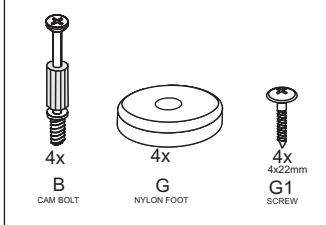
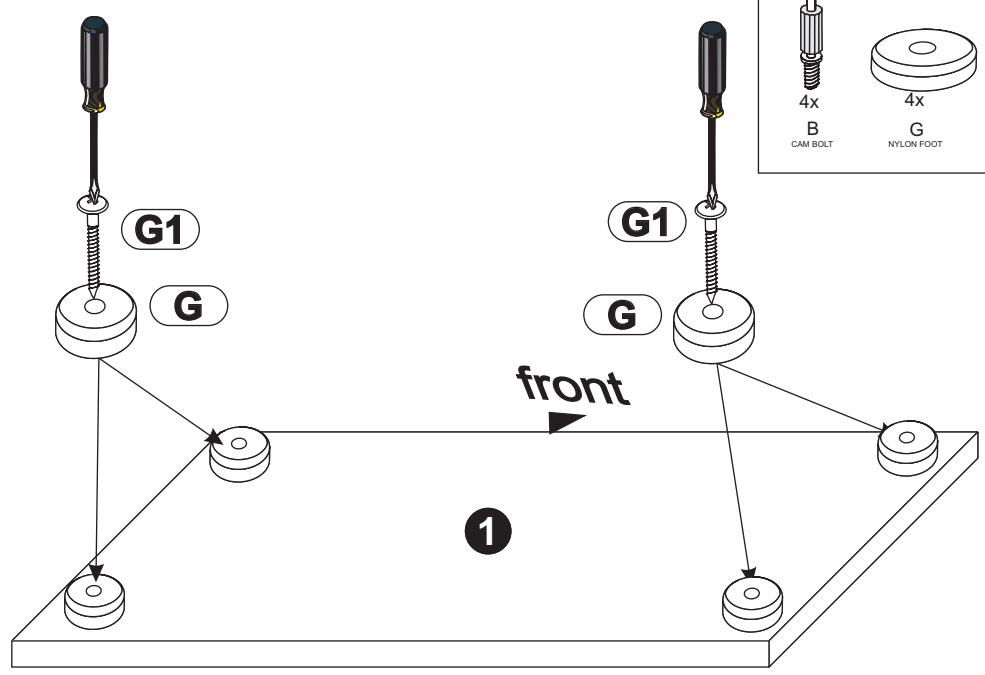
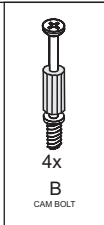
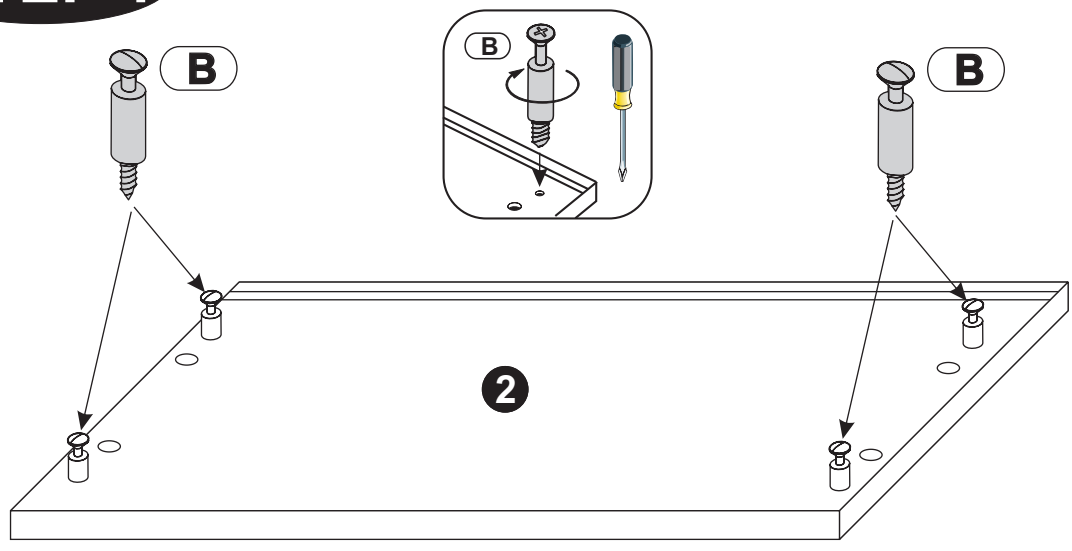

STEP 2

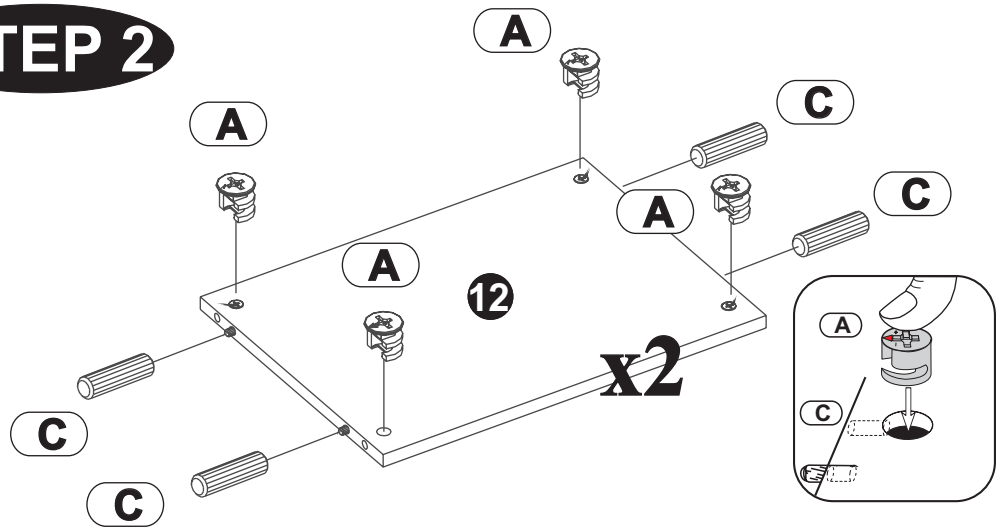

- 8x 15x12mm
A CAM LOCK
- 8x 8x28mm
C DOWEL

STEP 3

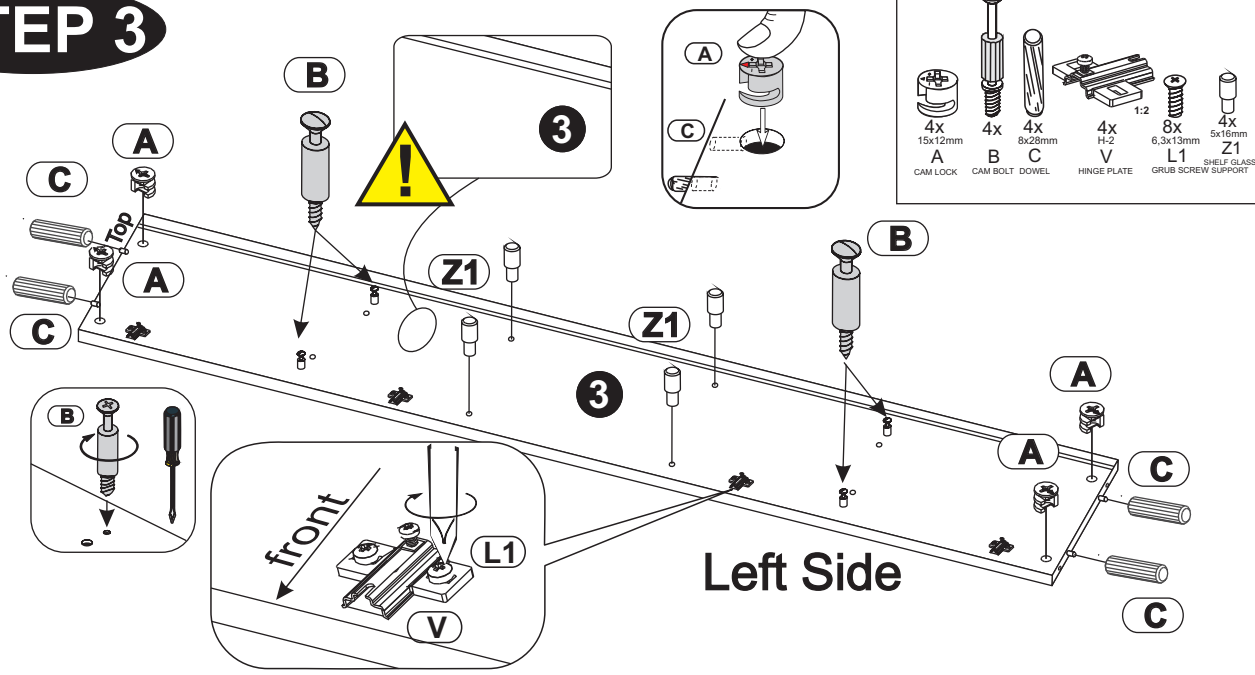

- 4x 15x12mm
A CAM LOCK
- 4x 8x28mm
B CAM BOLT
- 4x 8x28mm
C DOWEL
- 4x H-2
V HINGE PLATE
- 1:2
- 8x 6,3x13mm
L1 GRUB SCREW
- 5x16mm
Z1 SHELF GLASS SUPPORT
- 4x 5x16mm
Z1 SHELF GLASS SUPPORT

STEP 4

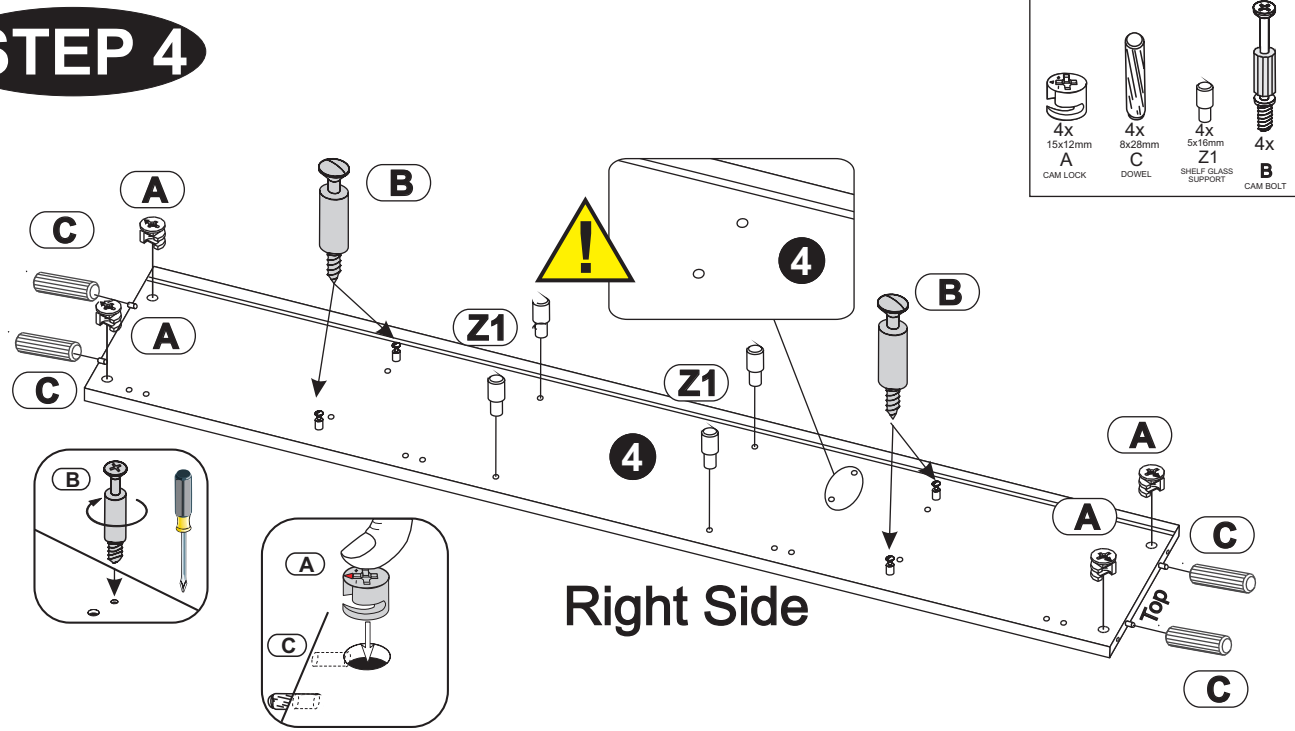

- 4x 15x12mm
A CAM LOCK
- 4x 8x28mm
C DOWEL
- 4x 5x16mm
Z1 SHELF GLASS SUPPORT
- 4x 5x16mm
Z1 SHELF GLASS SUPPORT
- 4x
B CAM BOLT

STEP 5

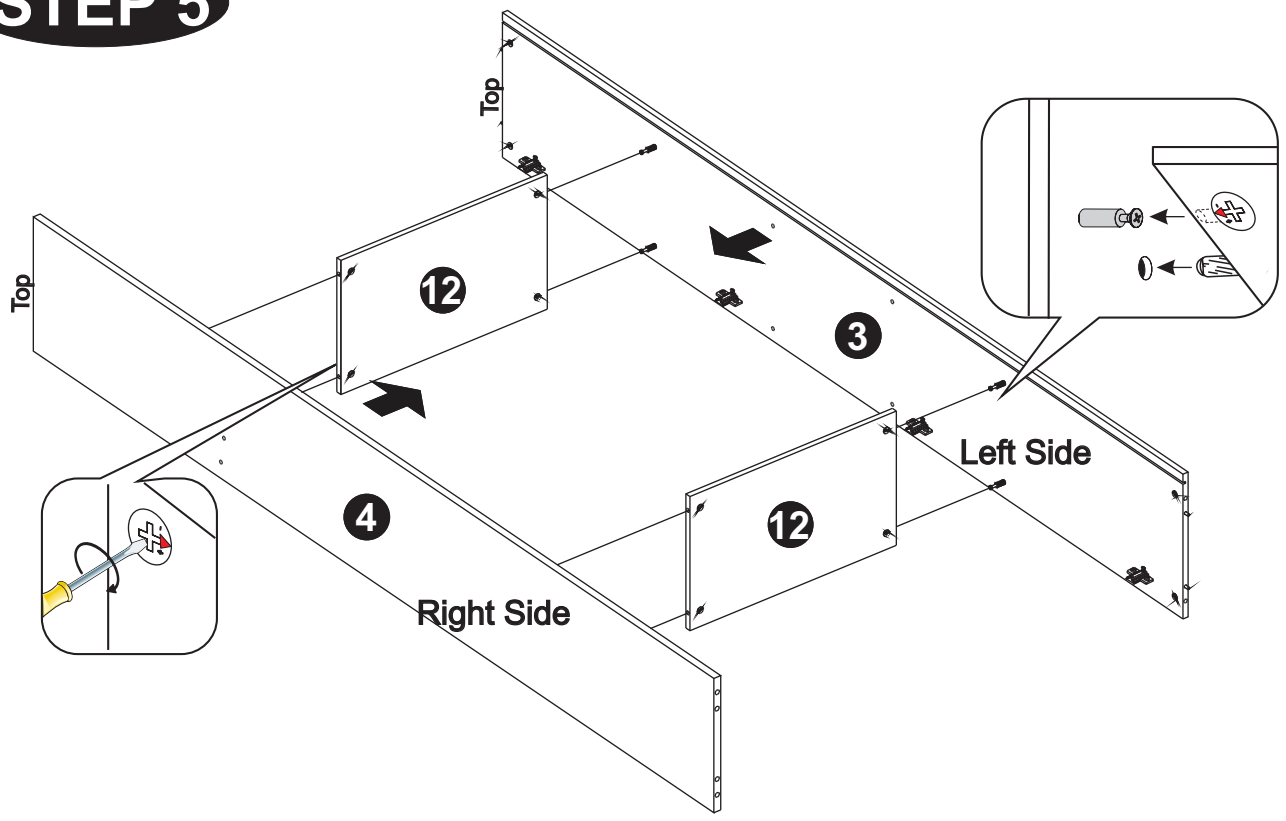



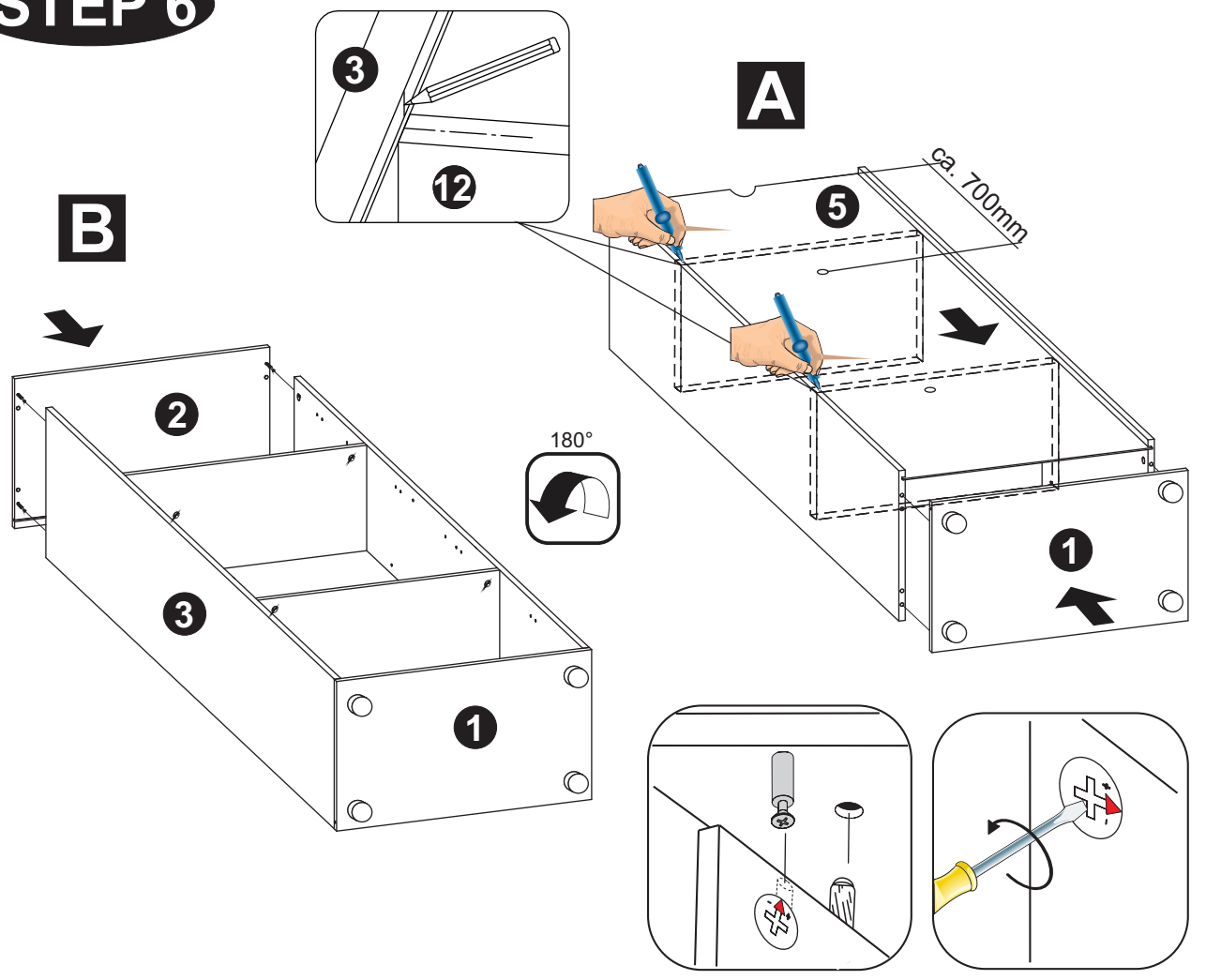

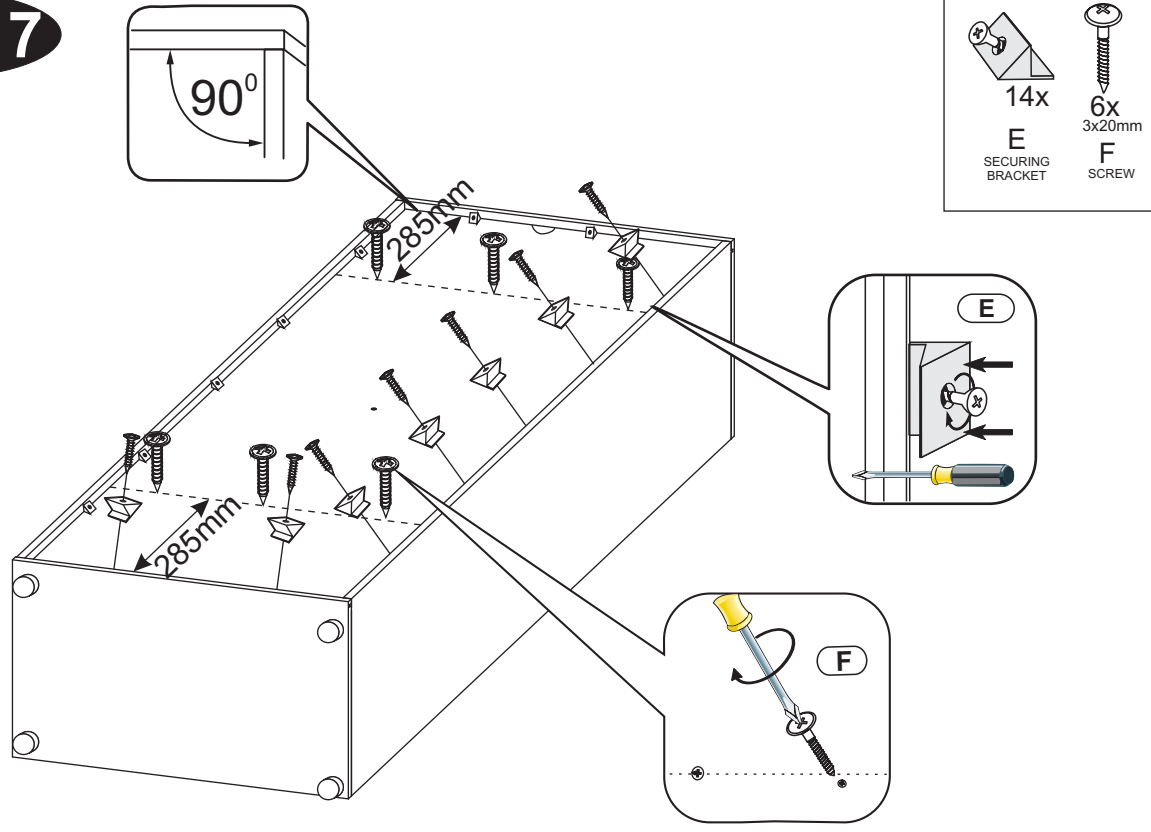

STEP 6



STEP 7





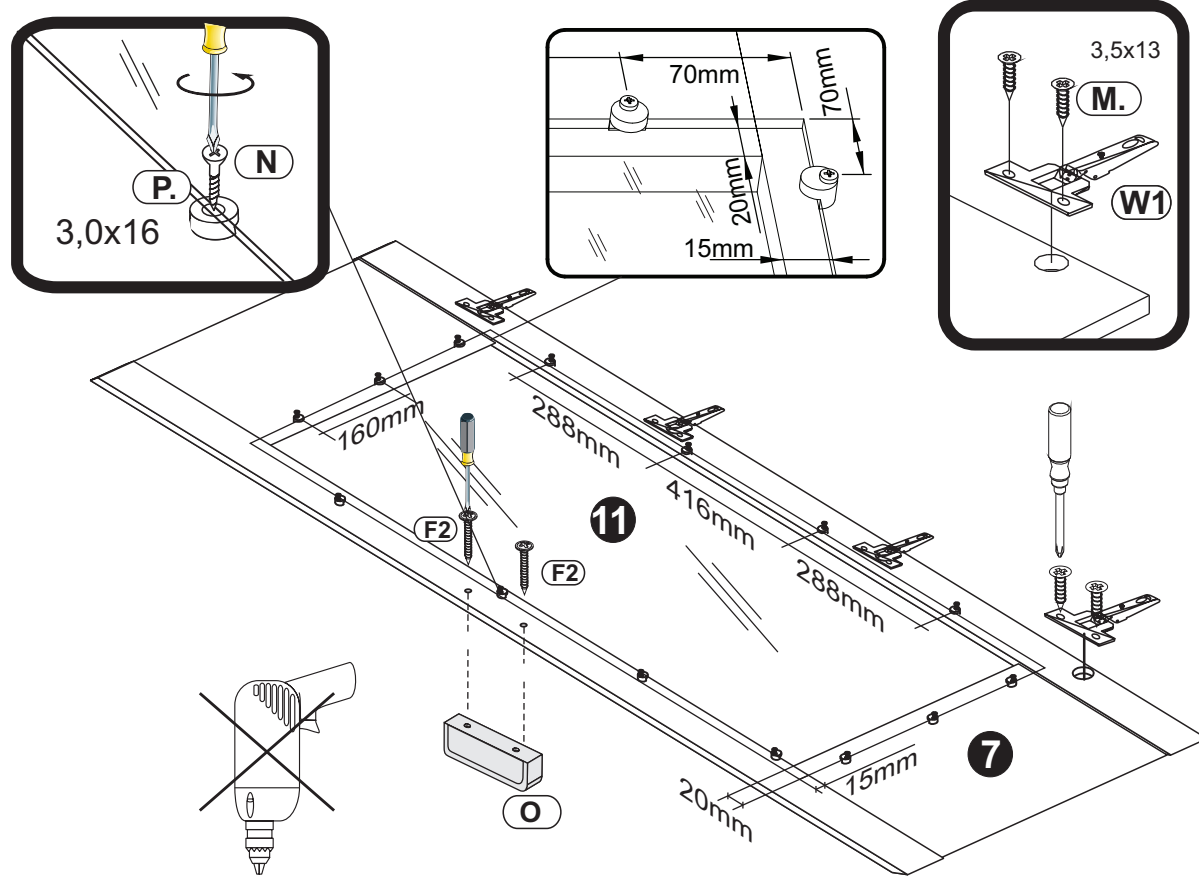

STEP 8

- 
8x
 3,5x13mm
M.
 SCREW
- 
14x
 3x16mm
N
 SCREW
- 
14x
P.
 GRIP DOOR
 GLASS
- 
2x
 4x30mm
F2
 SCREW
- 
1x
 L-64
O
 HANDLE
- 
 1:2
4x
 kr0
W1
 HINGE

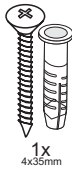

STEP 9

! LED Lights for type 06

- 
 2x
 H
 PEG
- 
 18x
 D
 CAM COVER
- 
 1x
 4x35mm
 R
 PLASTIC DOWEL
- 
 1x
 T
 ANGLE

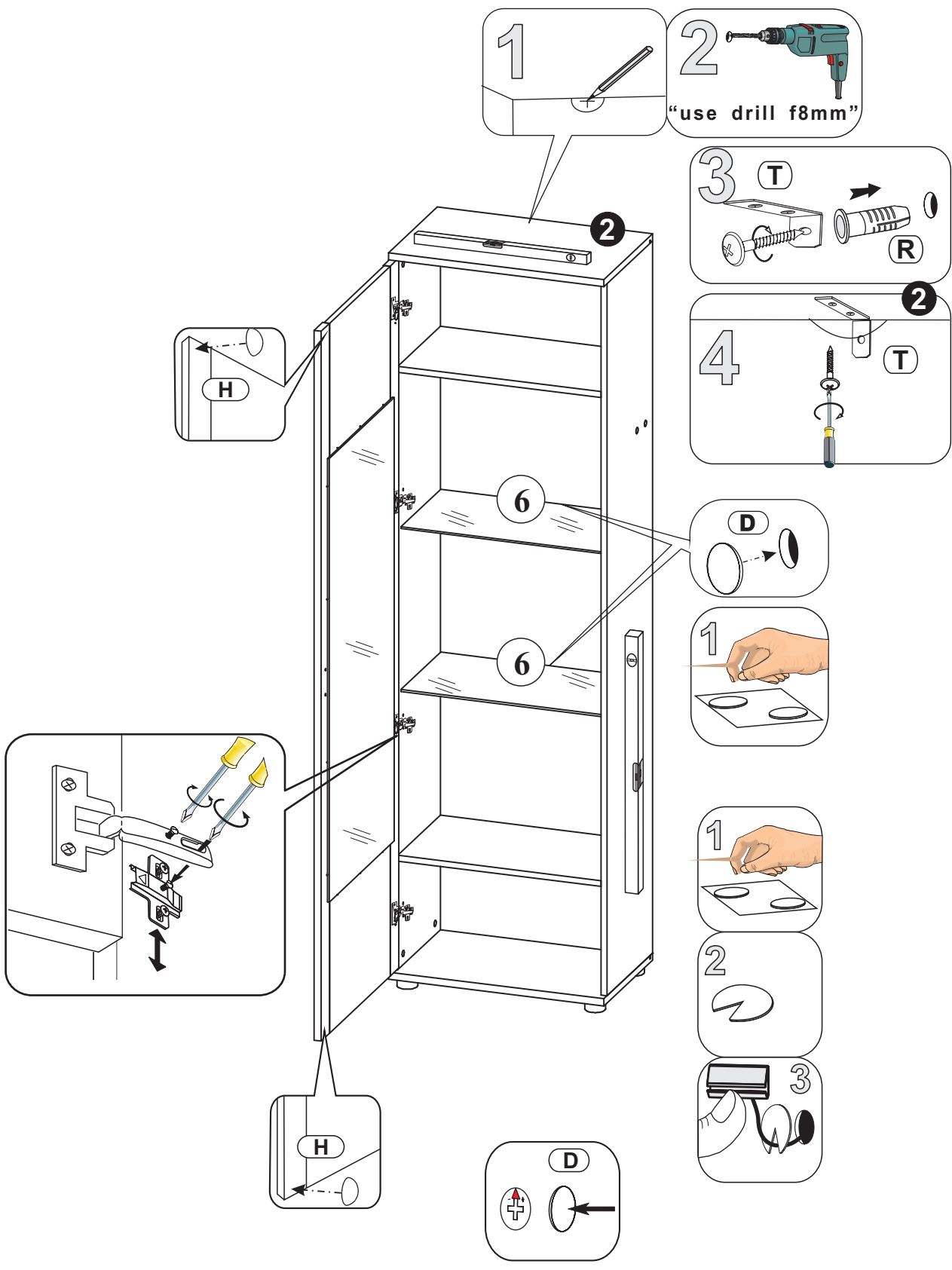

STEP 10

