

ASSEMBLY INSTRUCTION

DESCRIPTION: Type 319 BOOM P6--BH

2.5 hrs

APPROXIMATE ASSEMBLY TIME
EXCLUDING GLUE SETTING TIME

2 PERSON ASSEMBLY



FLOOR AREA
2,5M X 2,5M

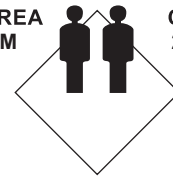

CEILING HEIGHT
2,0M

REQUIRED ASSEMBLY SPACE

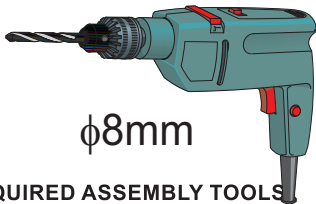

φ8mm

REQUIRED ASSEMBLY TOOLS

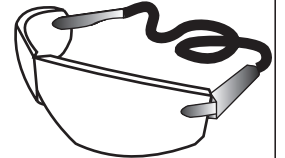
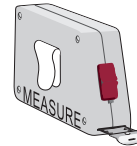

ASSEMBLED DIMENSIONS

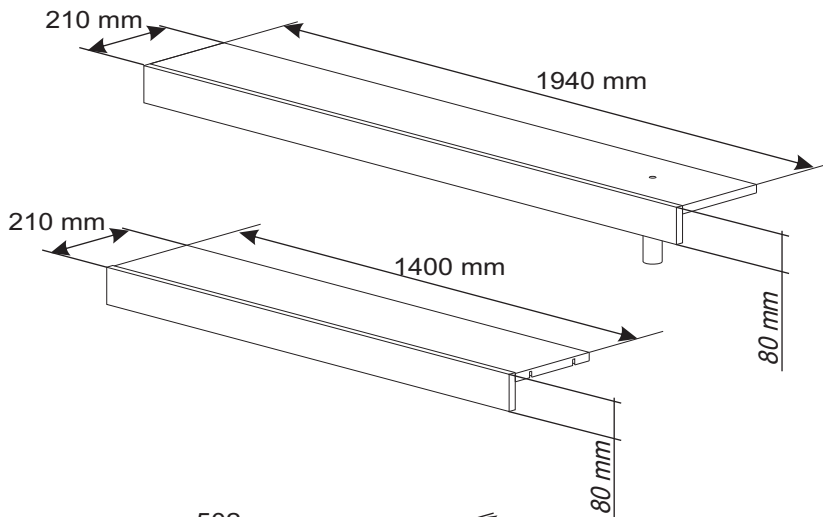

PACK 1
CONSISTS OF PARTS :
1, 2, 3, 4, 6, 8, 9, 11.
Fittings

PACK 2
CONSISTS OF PARTS :
5, 7, 10, 13, 14, 15, 16.

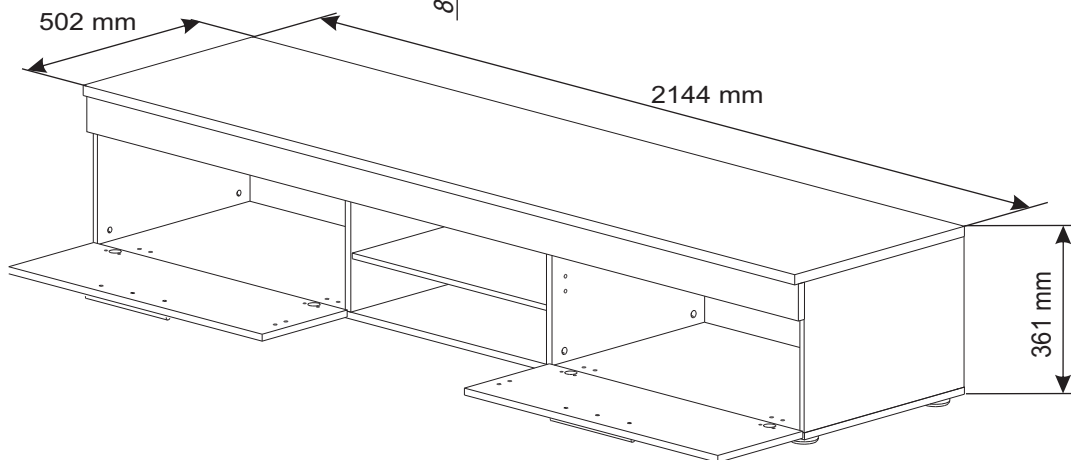

PART LIST

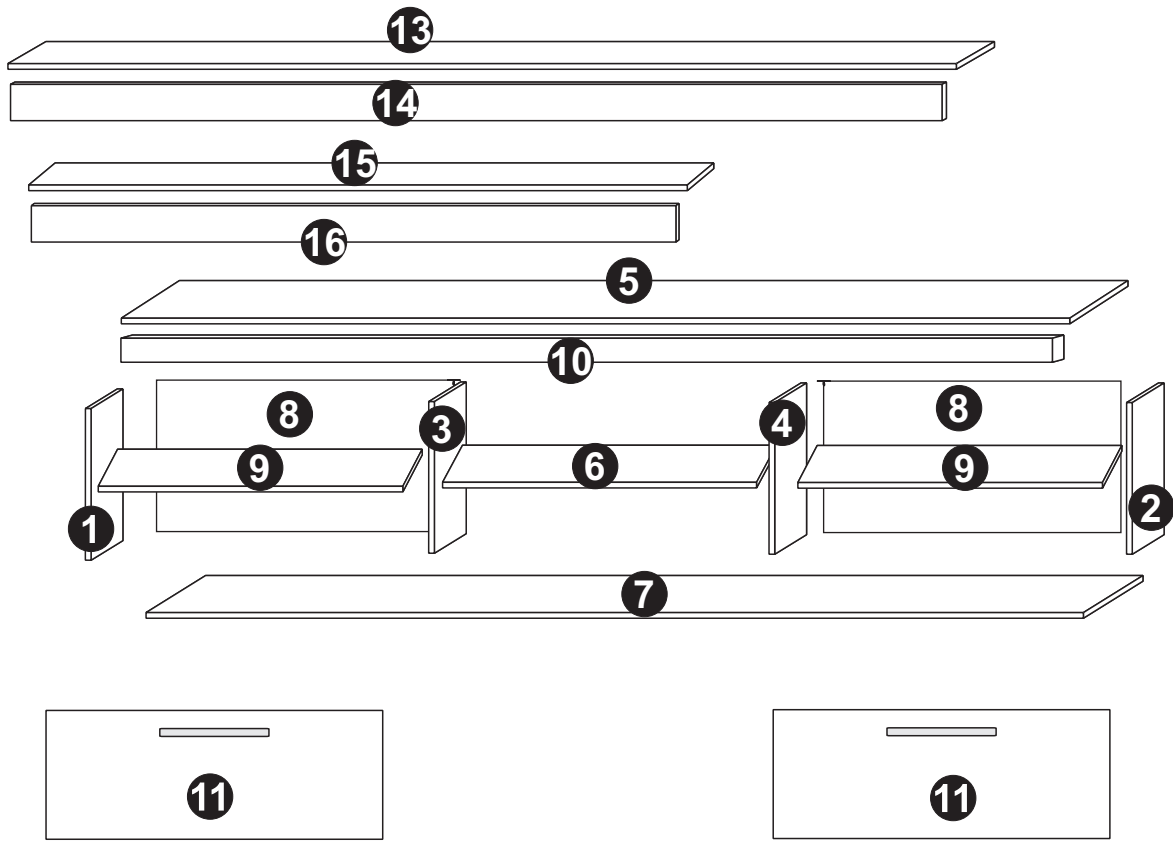

NO. PARTS LIST	QTY	NO. PARTS LIST	QTY
(1) LEFT SIDE PANEL	1	(13) HANGING SHELF	1
(2) RIGHT SIDE PANEL	1	(14) PLINTH 1	1
(3) LEFT DIVIDER	1	(15) BOTTOM HANGING SHELF	1
(4) RIGHT DIVIDER	1	(16) PLINTH 2	1
(5) TOP PANEL	1		
(6) SHELF	1		
(7) BOTTOM PANEL	1		
(8) BACK PANEL	2		
(9) R/L SHELF	2		
(10) PLINTH	1		
(11) FLAP	2		

HARDWARE LIST

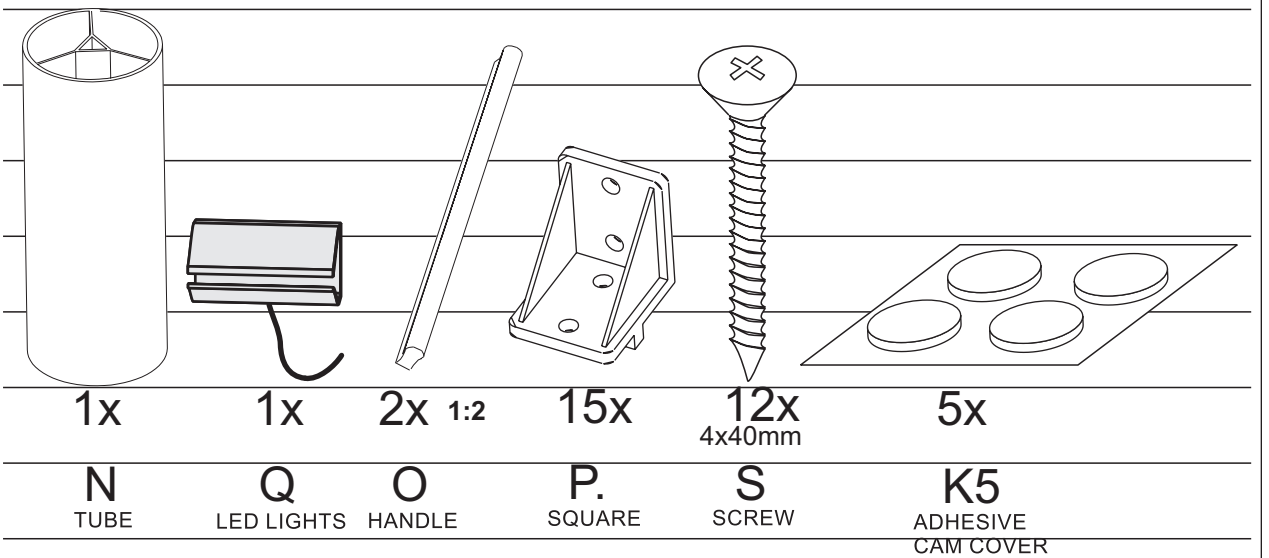
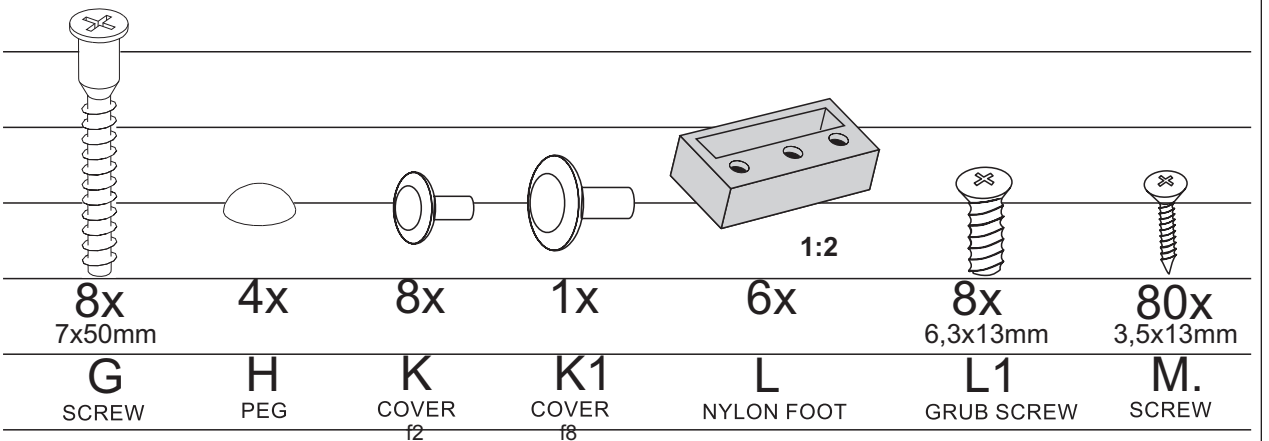
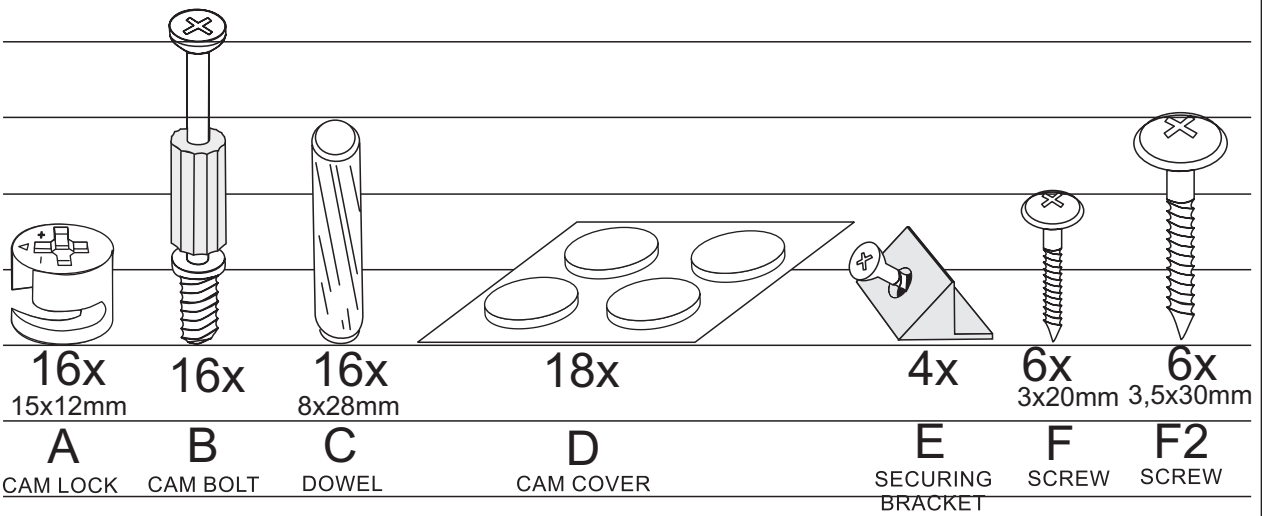

HARDWARE LIST

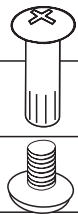

2x
Y

CONCATENATION

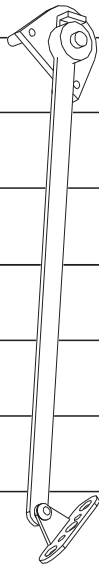

2x
U

FLAPS SETTING INDICATOR

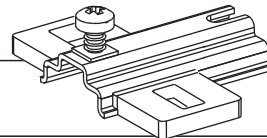

1:2

4x
H-2
V

HINGE PLATE

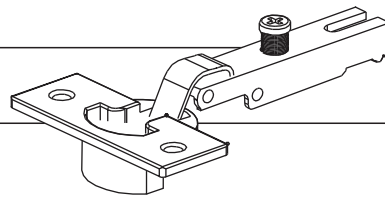

1:2

4x
kr0
W1

HINGE

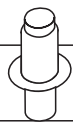

12x
5x16mm

Z

SHELF
SUPPORT



2x

X

LEVEL QUOIN

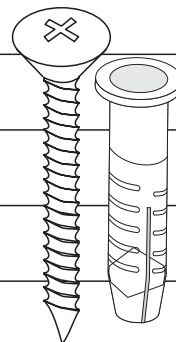

2x
4x35mm

R

PLASTIC
DOWEL

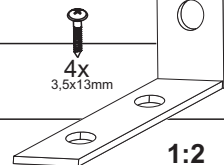

4x
3,5x13mm

1:2

2x

T

ANGLE

Top Tips before you start!

1. Please check that all parts are present before you start the assembly of your furniture, as once assembled, the furniture is exempt from our home approval policy.
2. For ease and speed of assembly, we recommend that before you commence each step of the assembly, that you identify all the parts required for that step.
3. For larger items, please ensure that you have sufficient space and people (as indicated on page 1) to assemble your product safely.
4. We recommend that, where possible, all items are assembled near to the area in which they will be placed in use, to avoid moving the product unnecessarily once assembled.
5. For the protection of your furniture, particularly items of high gloss finish, we recommend that the product is placed on a protected surface during assembly to prevent any damage.
6. During assembly please take care not to over-tighten any fittings, as this may damage the product .

Care and Maintenance of your Furniture

Please periodically check all fittings and re-tighten as necessary.

Please do not sit or stand on this item.

Never allow any kind of liquid to remain on your furniture. Absorption can cause wood to warp or finishes to de-laminate.



Please do not drag and pull your furniture.

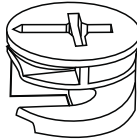

SPECIAL TIPS FOR FITTING CAM-LOCKS AND CAM-PILLARS

CAM-LOCK



WHEN FITTING CAMS
ENSURE STARTING POSITION IS CORRECT
BEFORE YOU INSERT CONNECTING CAM-PILLAR
TURN CLOCKWISE UNTILE SECURE

✓   ✗

CORRECT WRONG

Align with long point of cross

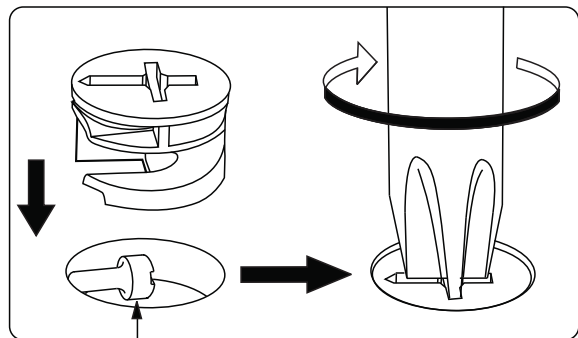

Pillar head needs to be in centre



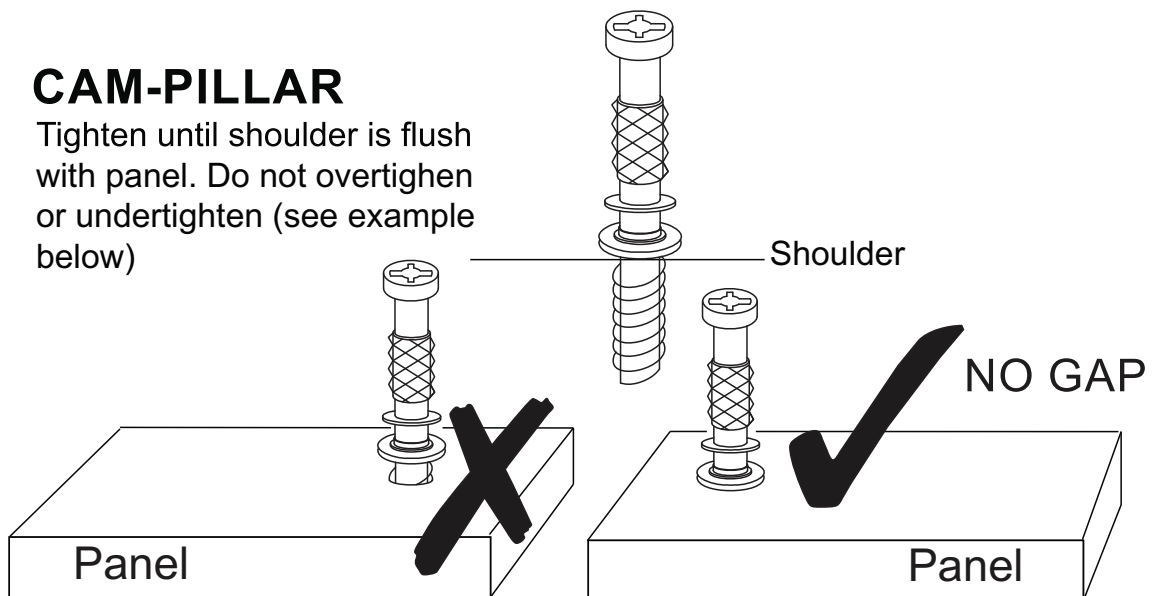

CAM-PILLAR

Tighten until shoulder is flush with panel. Do not overtighten or undertighten (see example below)

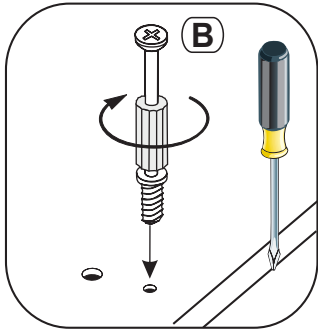

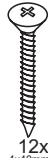
STEP 1

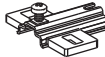

-  12x 4x40mm S SCREW
-  6x L NYLON FOOT
-  16x B CAM BOLT
-  4x H-2 V HINGE PLATE
-  8x 6.3x13mm L1 GRUB SCREW

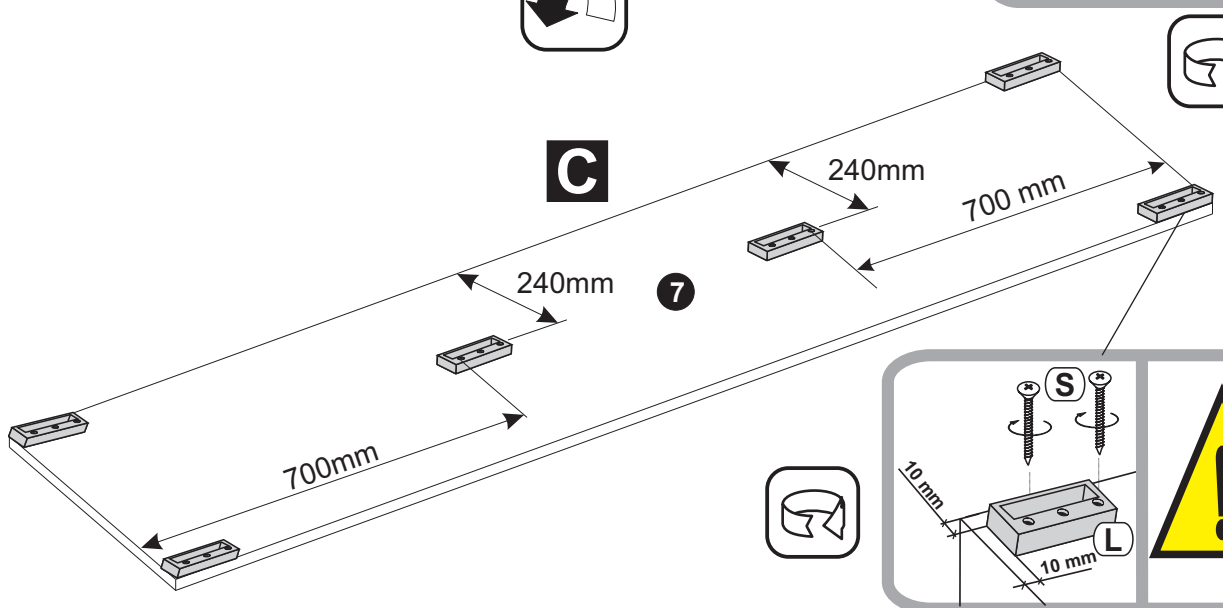
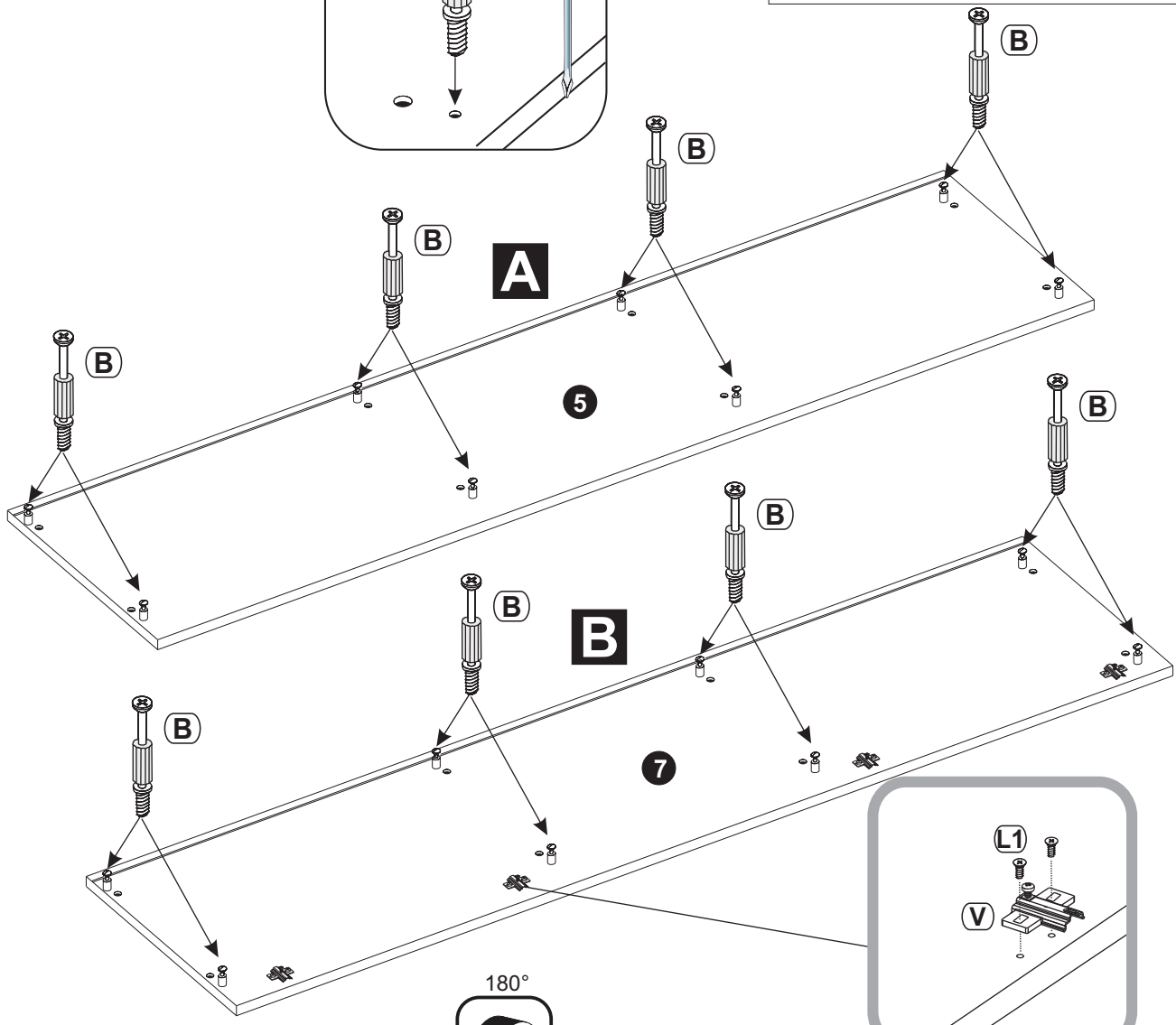

STEP 2

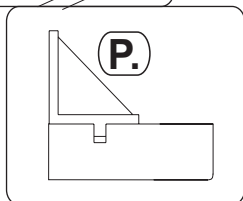
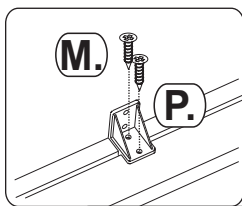

6x
P.
SQUARE



12x
3,5x13mm
M.
SCREW

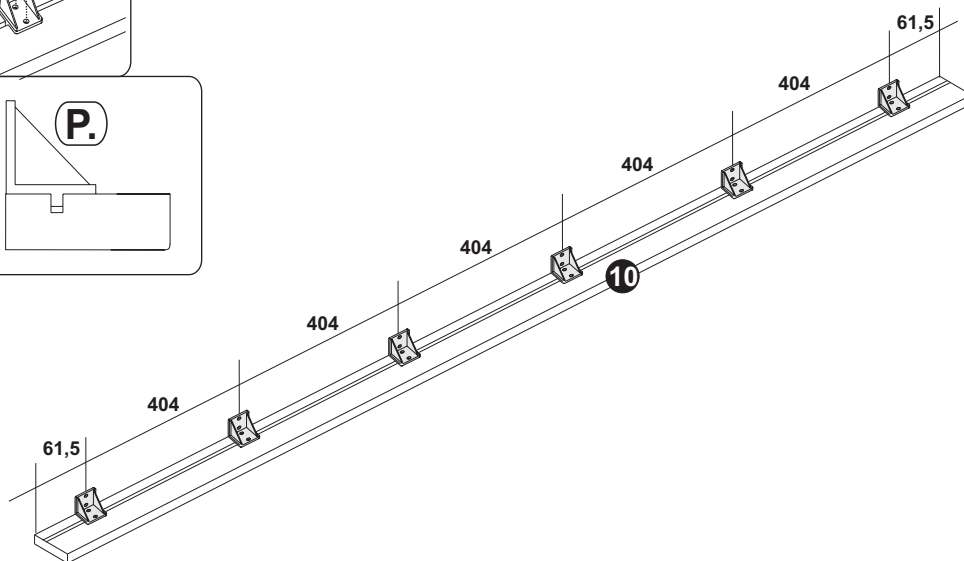

STEP 3

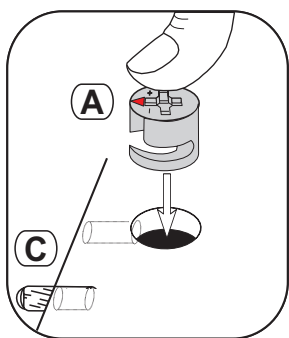

16x
15x12mm
A
CAM LOCK



16x
8x28mm
C
DOWEL

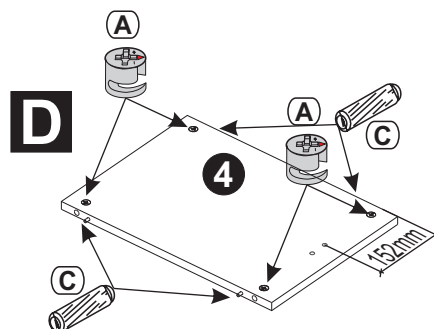
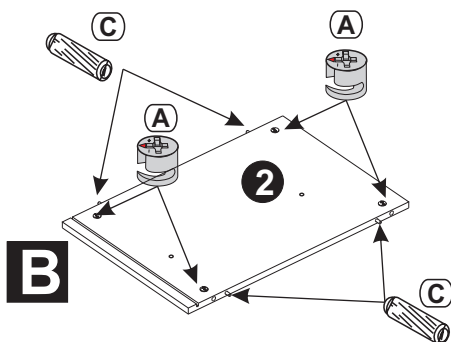
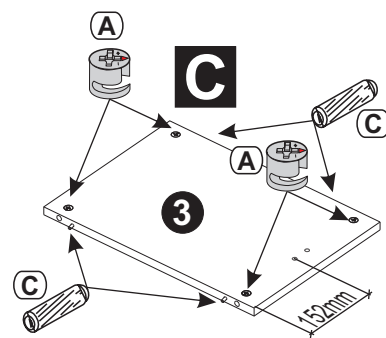
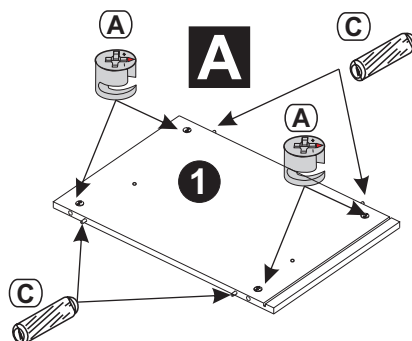

STEP 4

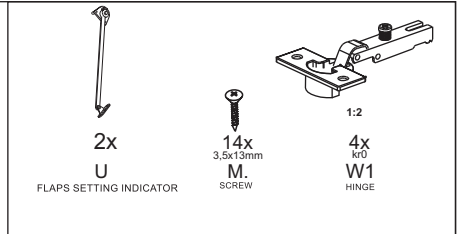

2x
U
FLAPS SETTING INDICATOR

14x
3,5x13mm
M.
SCREW

1:2
4x
K10
W1
HINGE

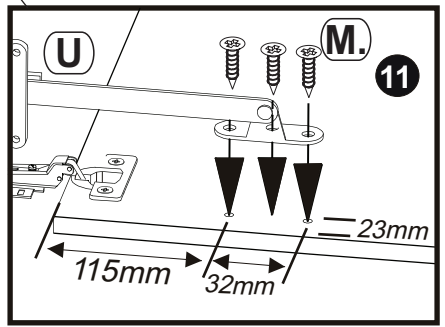
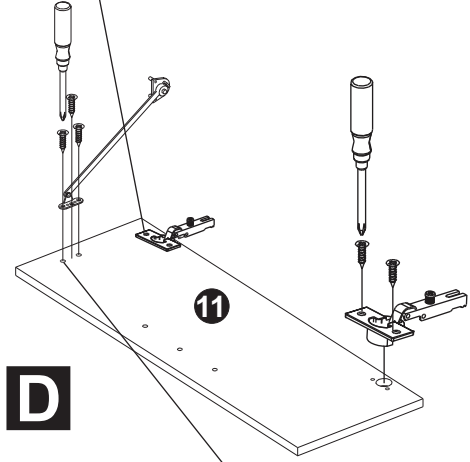
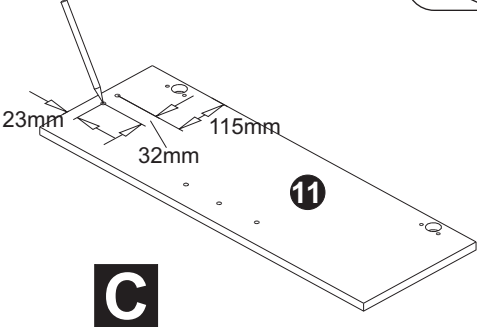
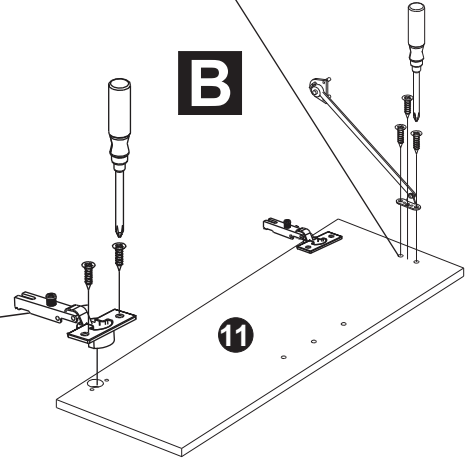
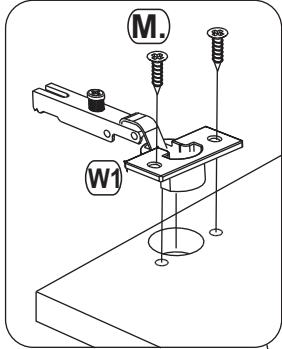
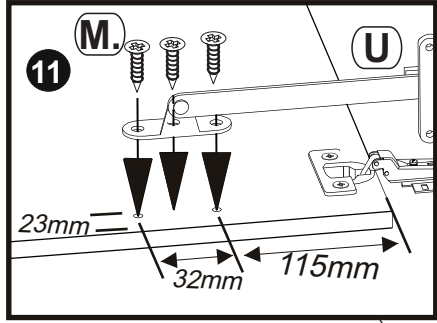
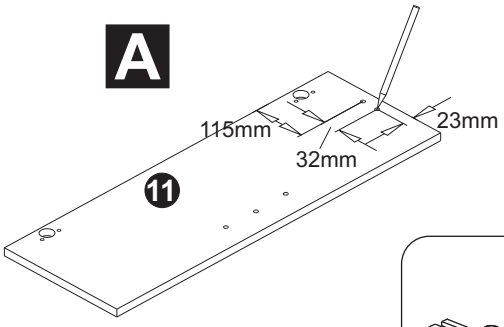

STEP 5

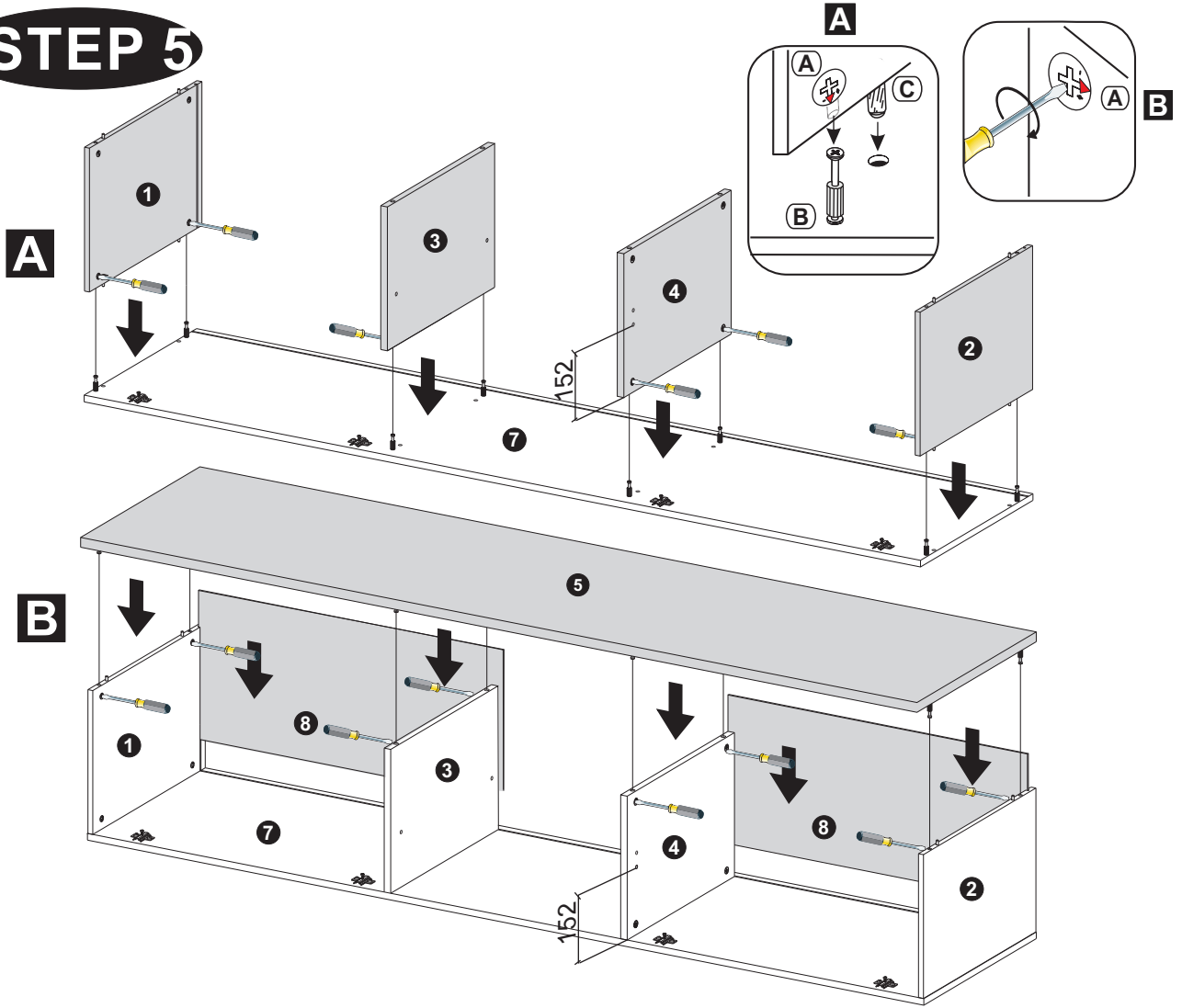

STEP 6

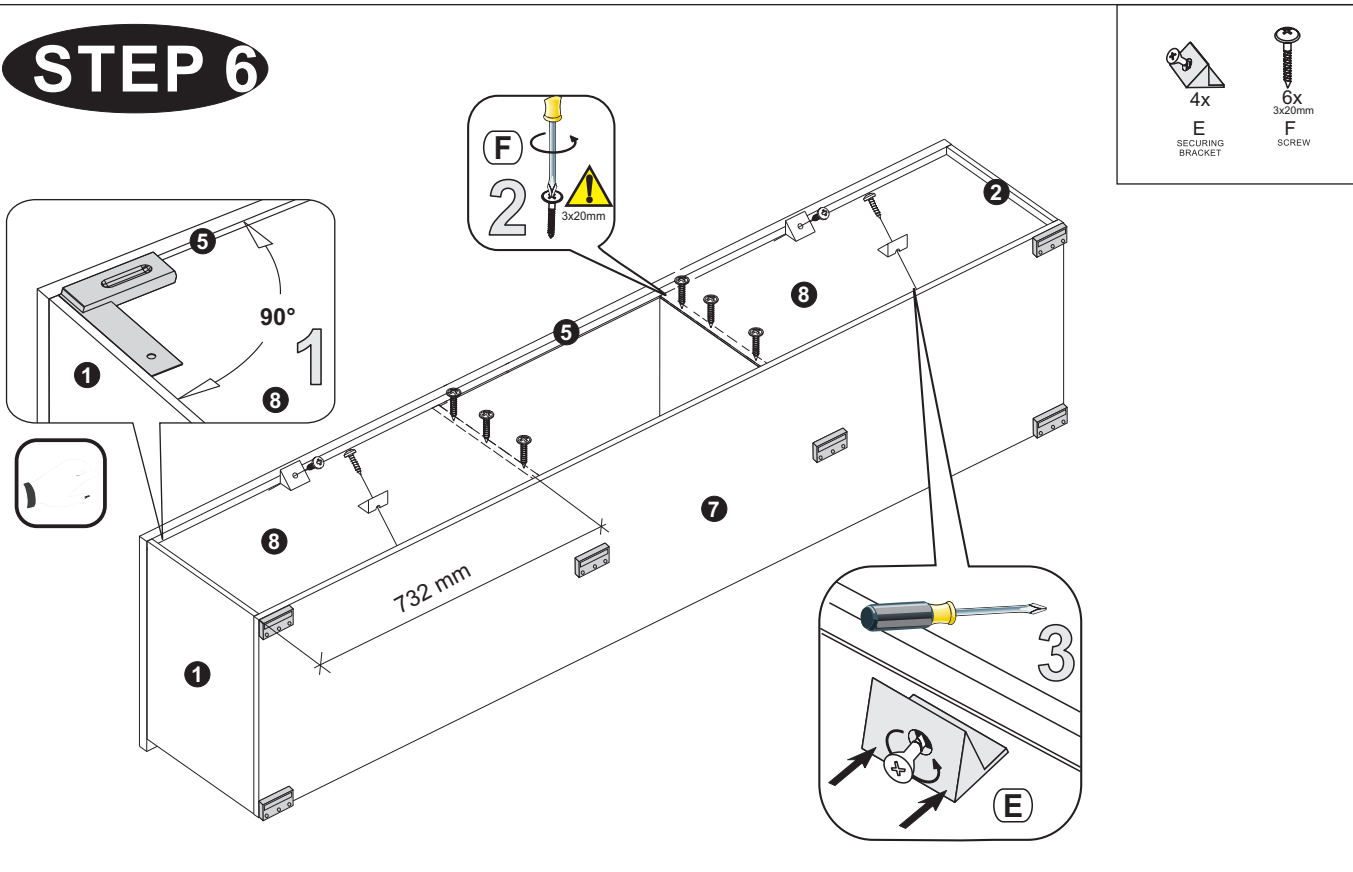

STEP 7

12x
3.5x13mm
M.
SCREW

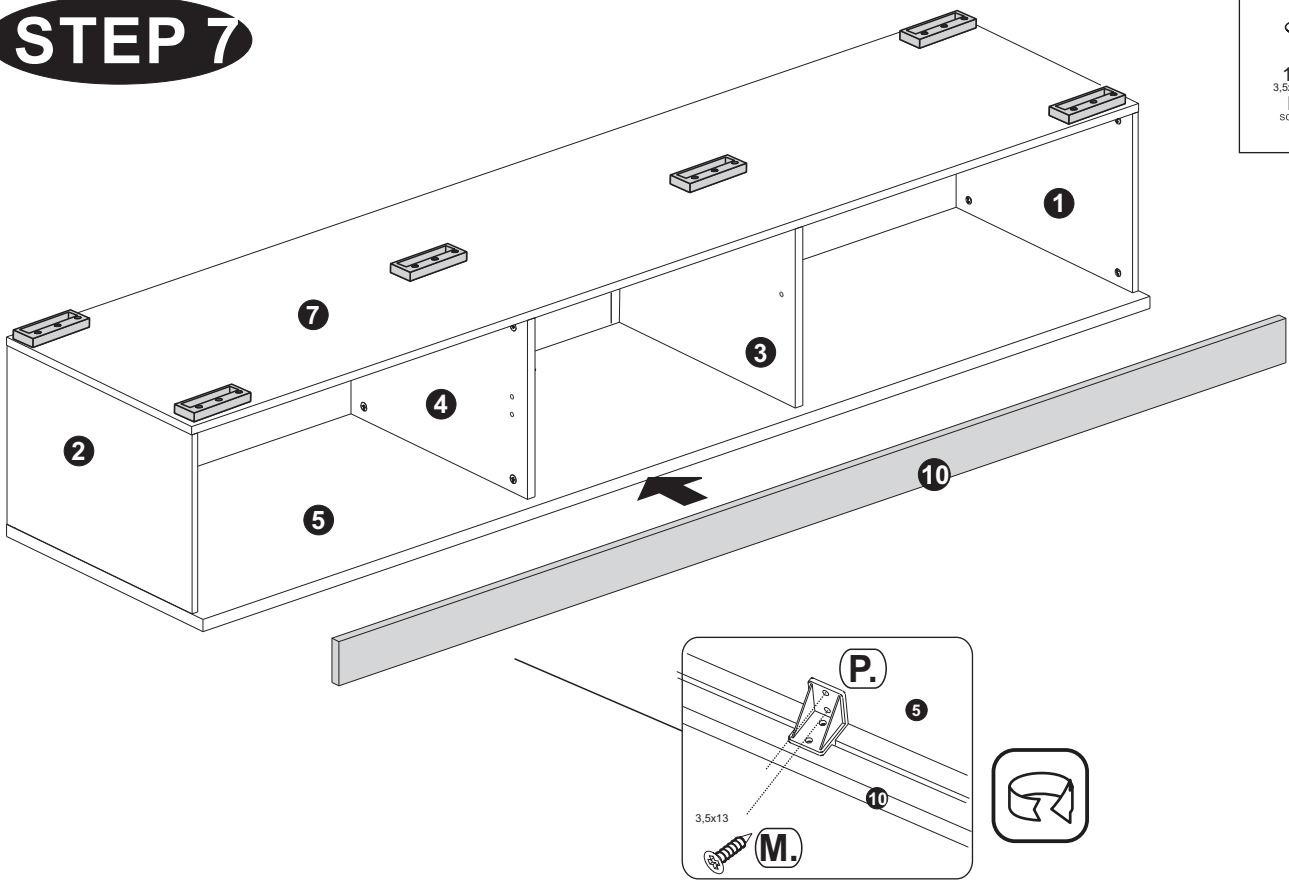

STEP 8

4x
5x15mm
Z
SHELF
SUPPORT

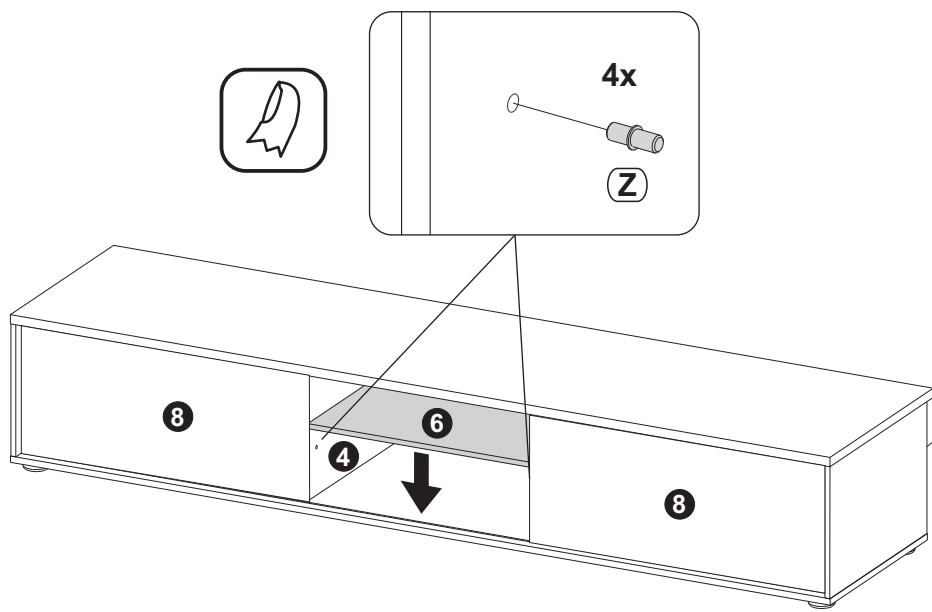

STEP 9

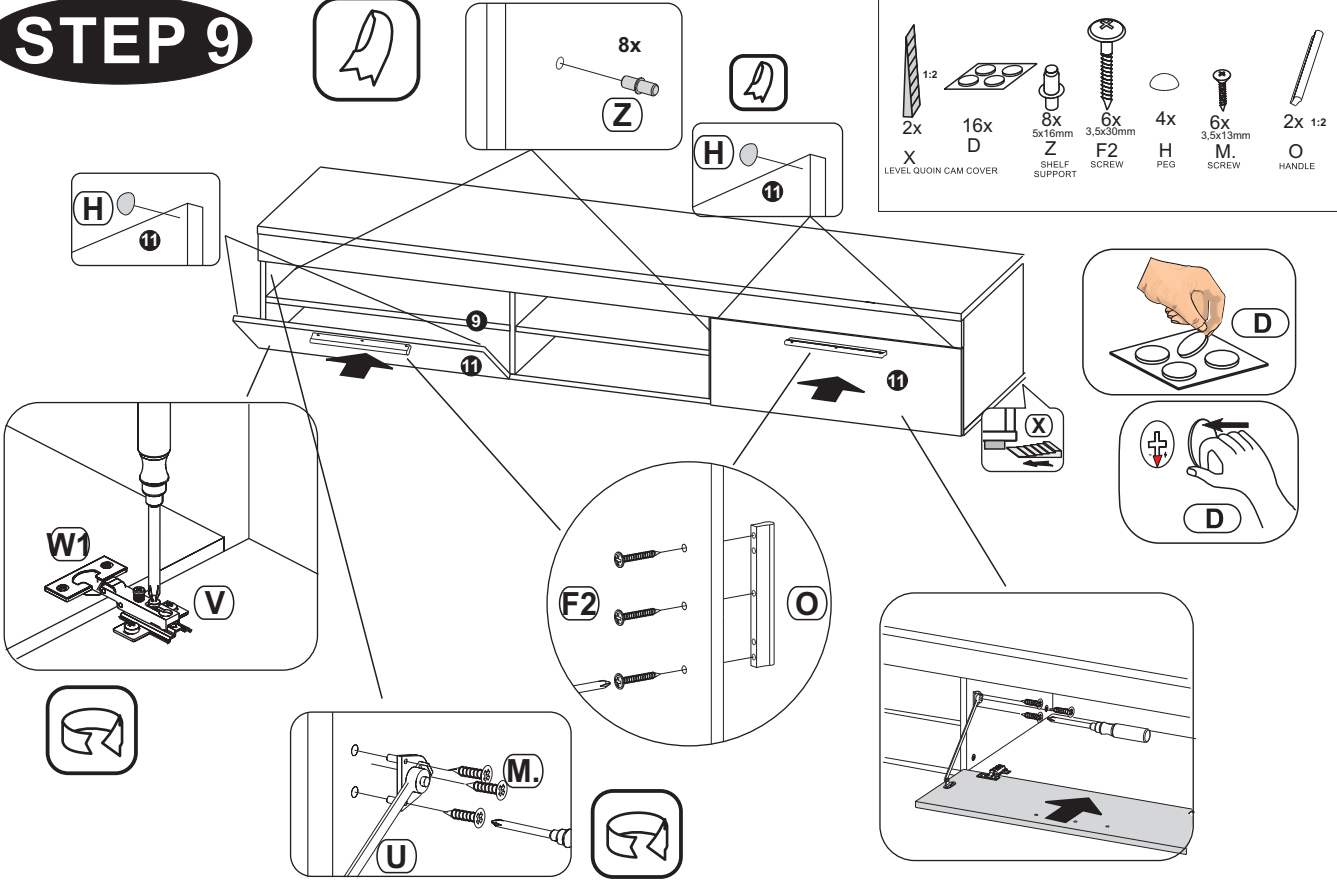

- 2x 1:2 X LEVEL QUOIN CAM COVER
- 16x D SHELF SUPPORT
- 8x 5x16mm Z SHELF SUPPORT
- 6x 3.5x30mm F2 SCREW
- 4x H PEG
- 6x 3.5x13mm M. SCREW
- 2x 1:2 O HANDLE

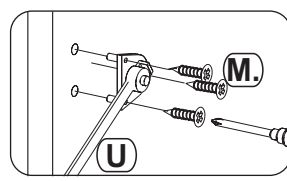
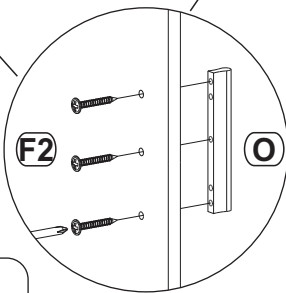
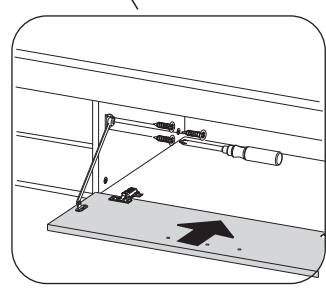
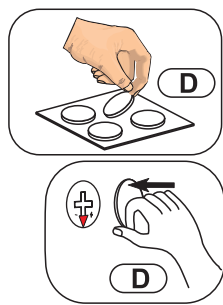

STEP 10

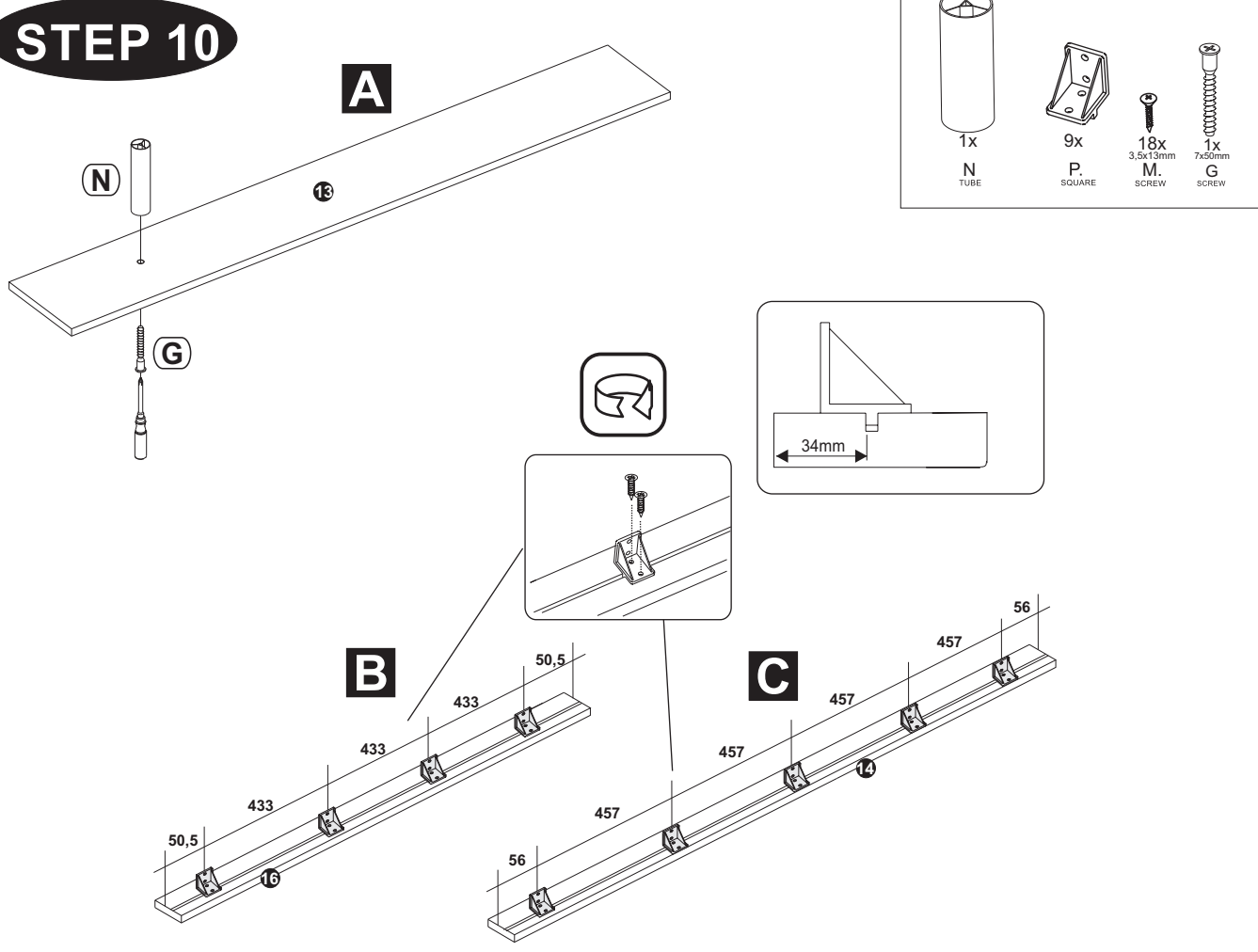

- 1x N TUBE
- 9x P SQUARE
- 18x 3.5x13mm M. SCREW
- 1x 7x50mm G SCREW

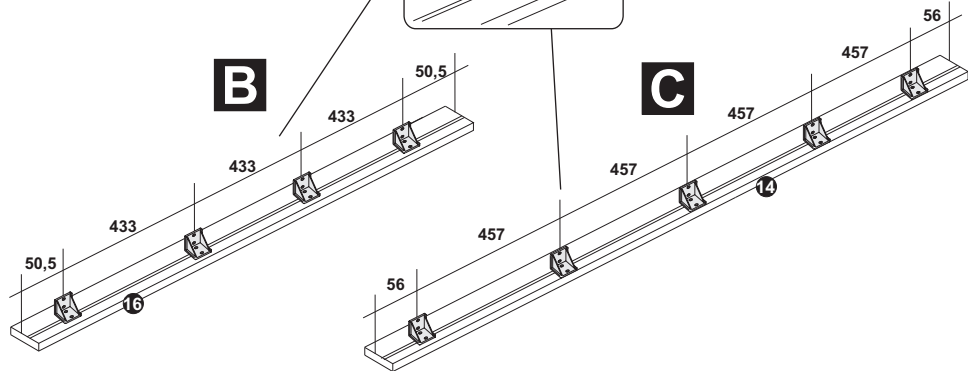
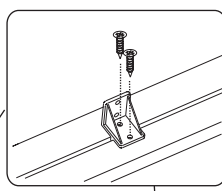
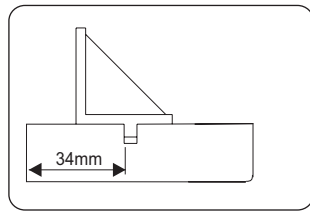

STEP 11

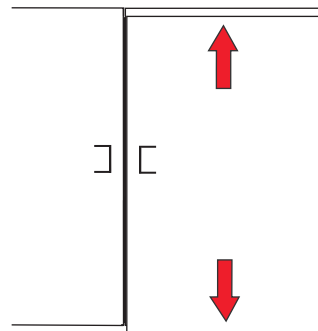
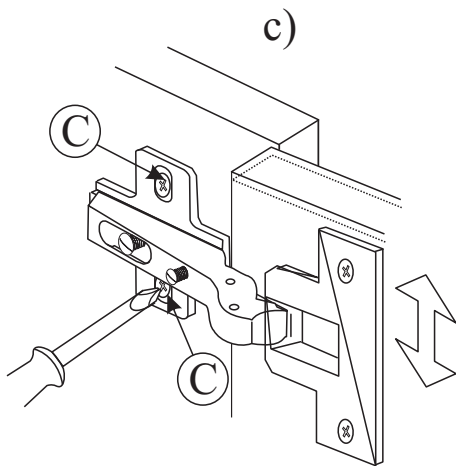
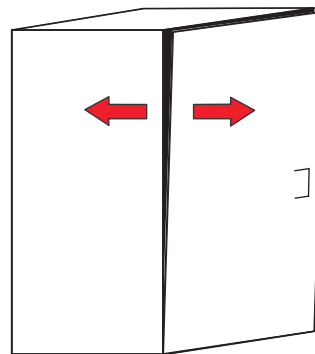
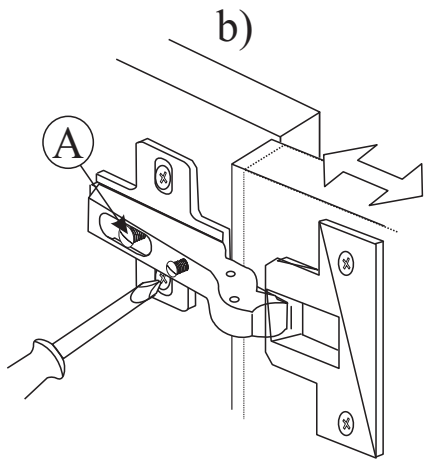
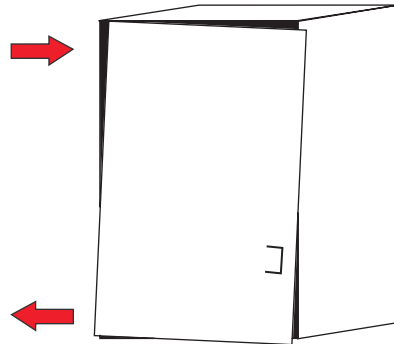
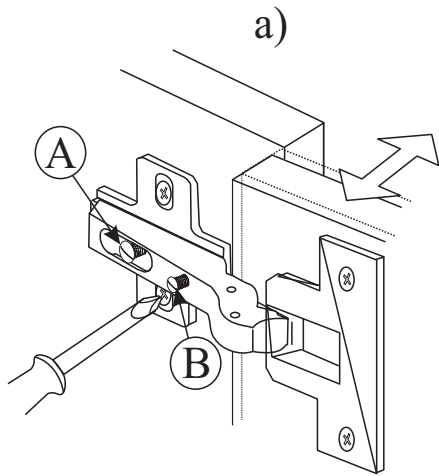

STEP 12

18x
3,5x13mm
M.
SCREW

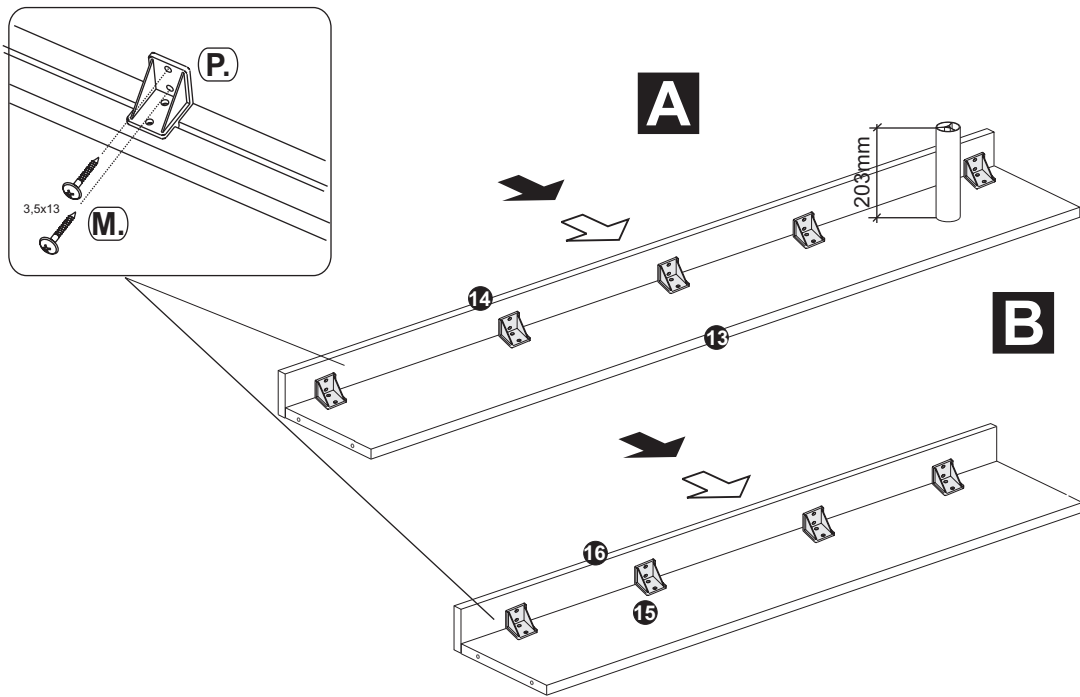

C

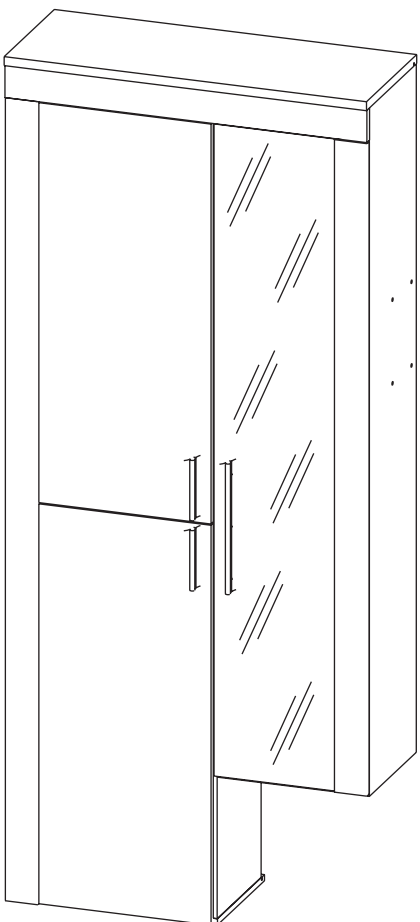

D

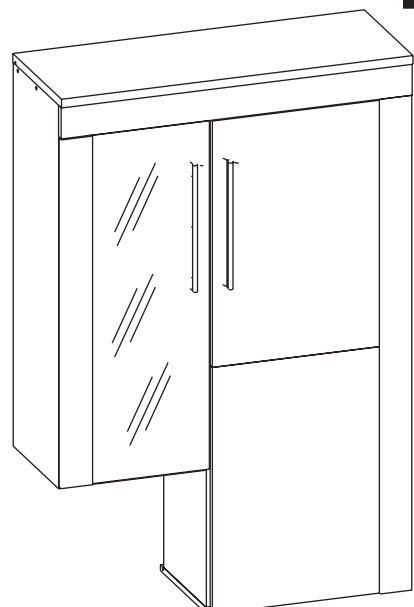



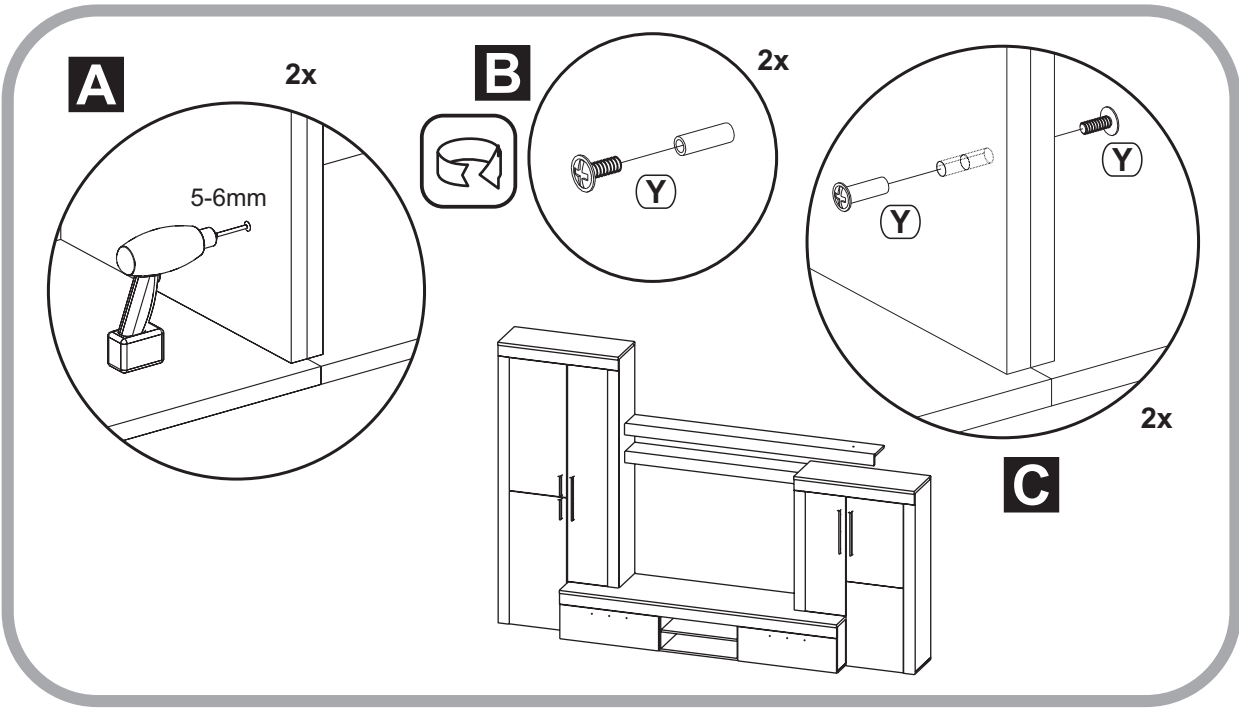
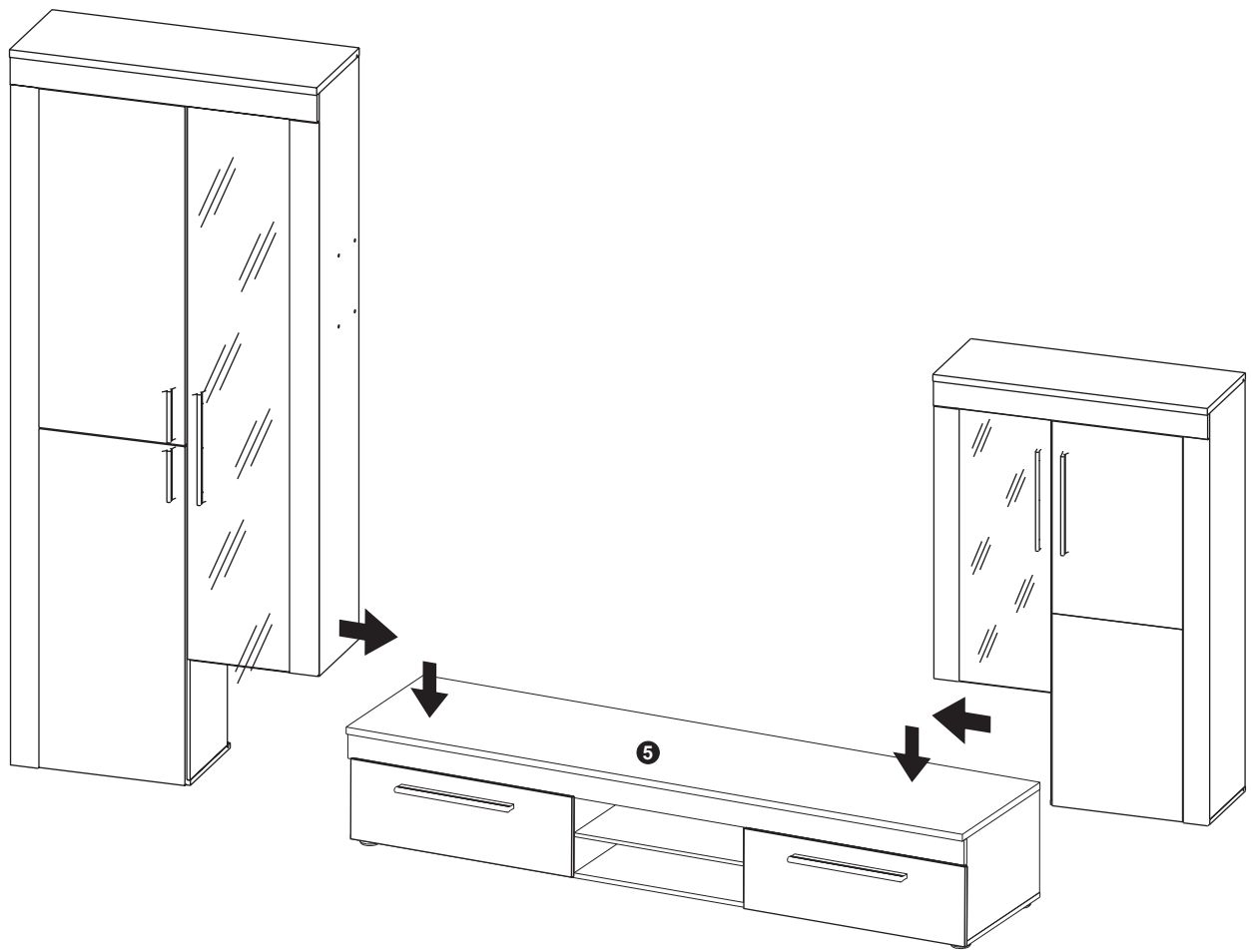

STEP 13

2x
Y
CONCATENATION

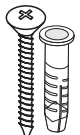

STEP 14

- 
 1x
 Q
 LED LIGHTS
- 
 5x
 K5
 ADHESIVE
 CAM COVER
- 
 7x
 7x50mm
 G
 SCREW
- 
 2x
 4x35mm
 R
 PLASTIC
 DOWEL
- 
 2x
 T
 ANGLE
- 
 8x
 K
 COVER
 IS

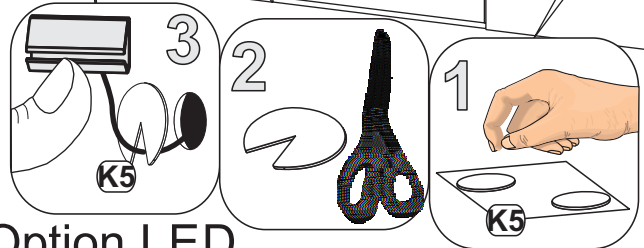
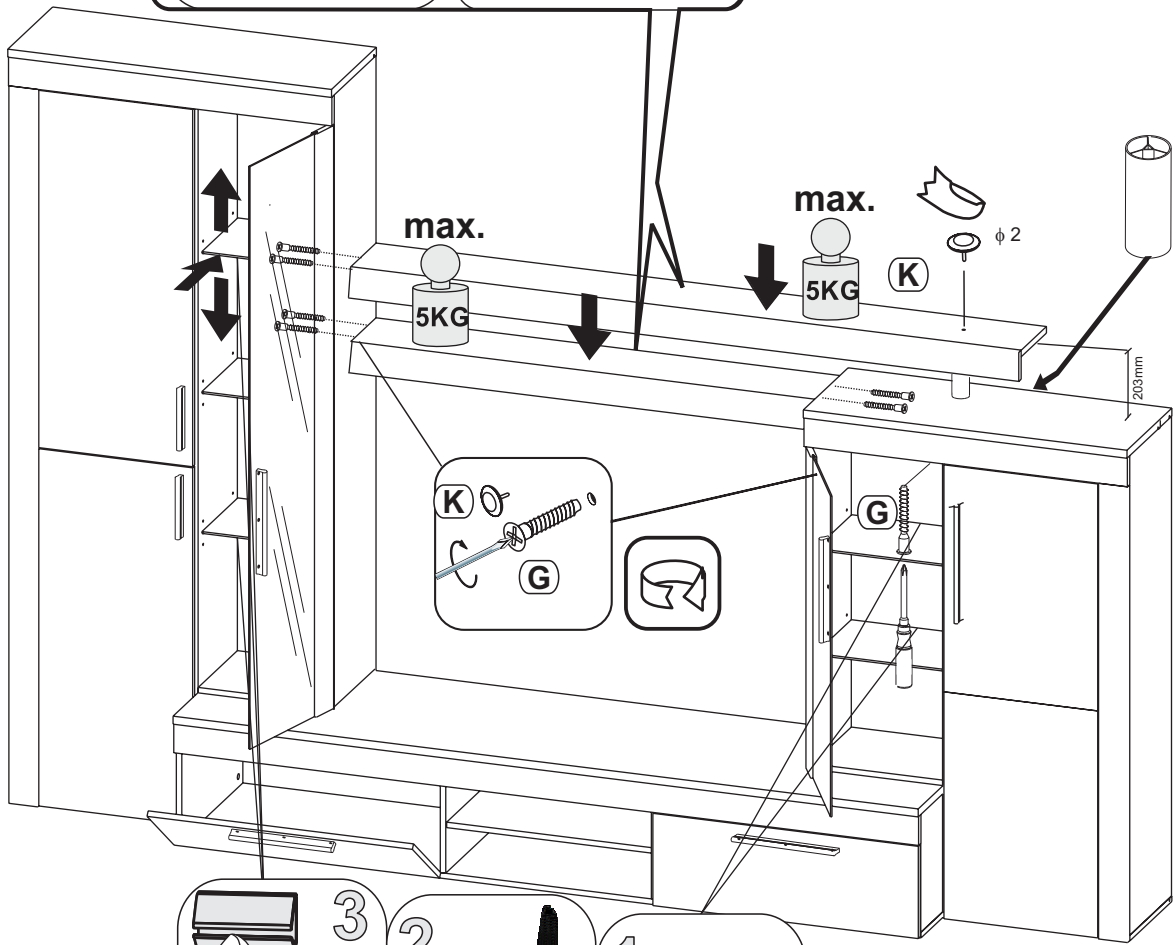
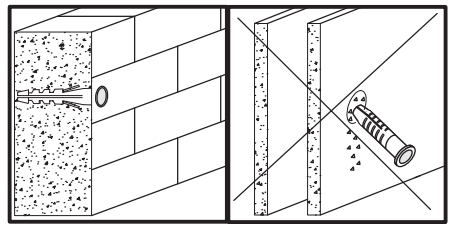
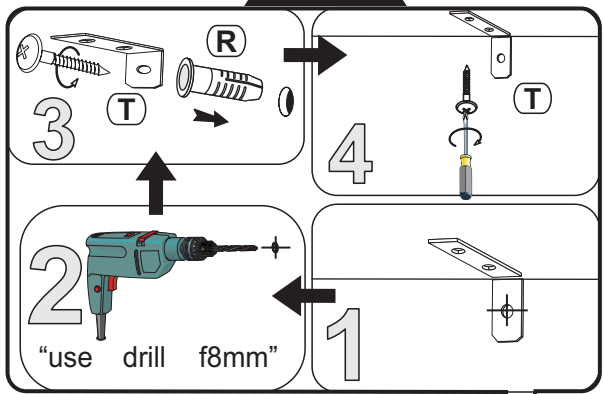

Option LED