

ASSEMBLY INSTRUCTION

DESCRIPTION: Type 135 BOOM P6--BH

2.5 hrs

APPROXIMATE ASSEMBLY TIME
EXCLUDING GLUE SETTING TIME

2 PERSON ASSEMBLY



FLOOR AREA
2,5M X 2,5M

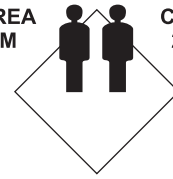

CEILING HEIGHT
2,0M

REQUIRED ASSEMBLY SPACE

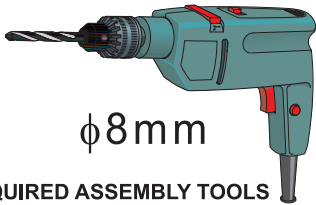

$\phi 8\text{mm}$

REQUIRED ASSEMBLY TOOLS

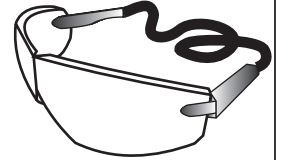
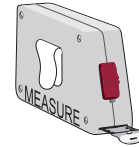
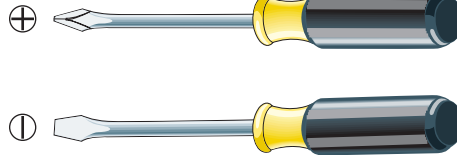

ASSEMBLED DIMENSIONS

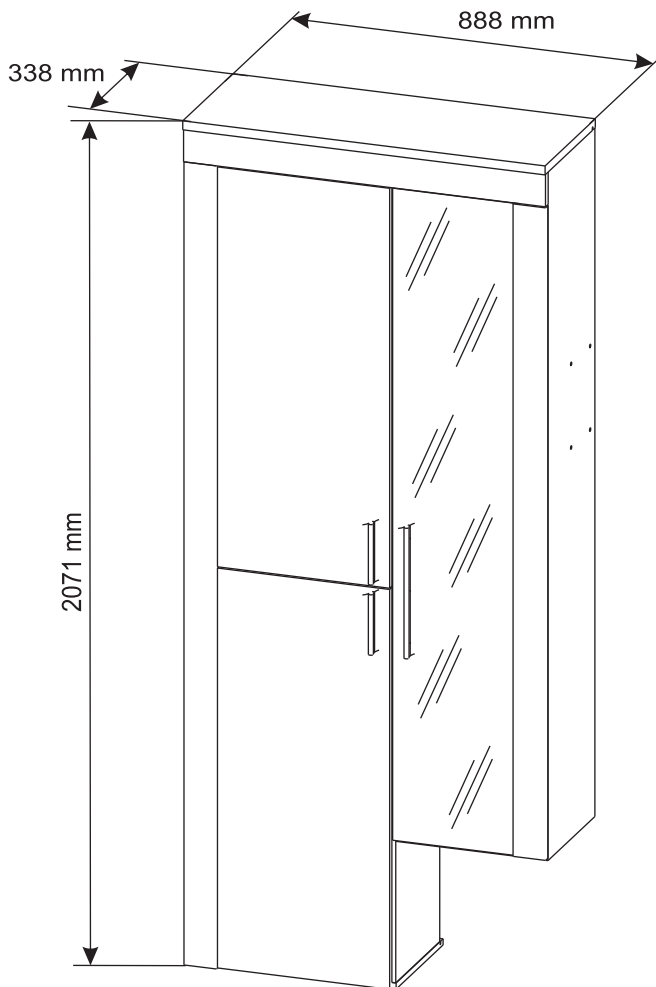

PACK 1

CONSISTS OF PARTS :

1, 3, 12, 21, 24.

Fittings

PACK 2

CONSISTS OF PARTS :

2, 5, 6, 7, 8, 9, 13, 25,

34, 40.

PART LIST

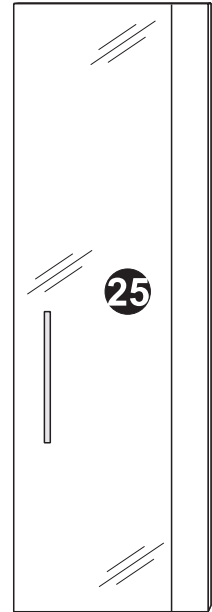
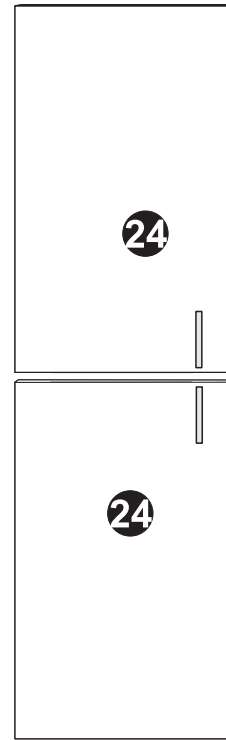
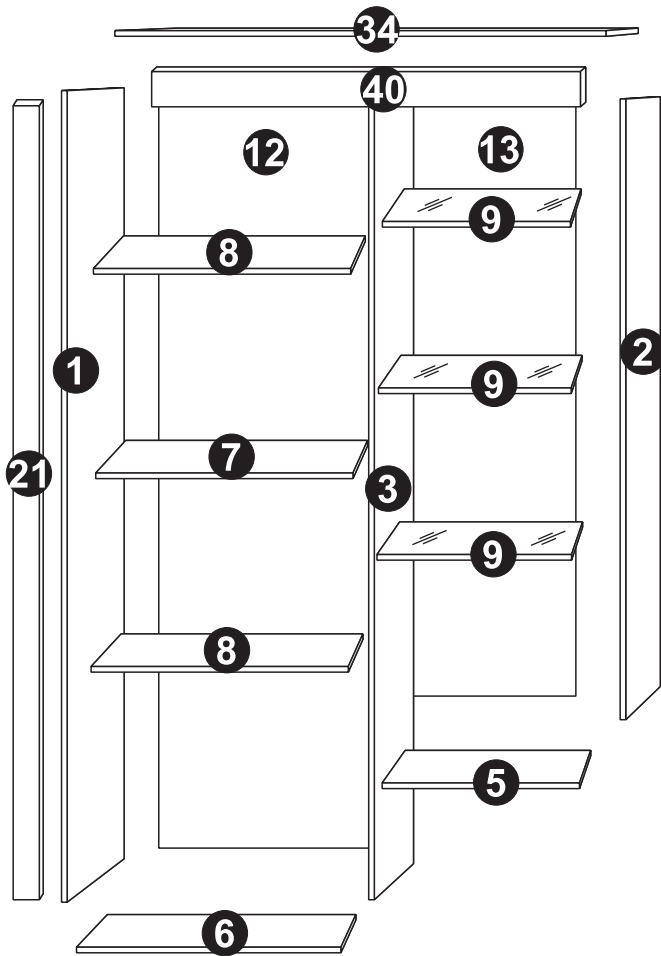

NO. PARTS LIST	QTY	NO. PARTS LIST	QTY
(1) LEFT SIDE PANEL	1	(24) LEFT DOOR	2
(2) RIGHT SIDE PANEL	1	(25) RIGHT DOOR W/GLASS	1
(3) CENTER DIVIDER	1	(40) PLINTH	1
(34) TOP PANEL	1		
(5) HORIZONTAL DIVIDER	1		
(6) BOTTOM PANEL	1		
(7) LEFT HORIZONTAL DIVIDER	1		
(8) SHELF	2		
(9) SHELF GLASS	3		
(12) LEFT BACK PANEL	1		
(13) RIGHT BACK PANEL	1		
(21) LEFT PLINTH			

HARDWARE LIST

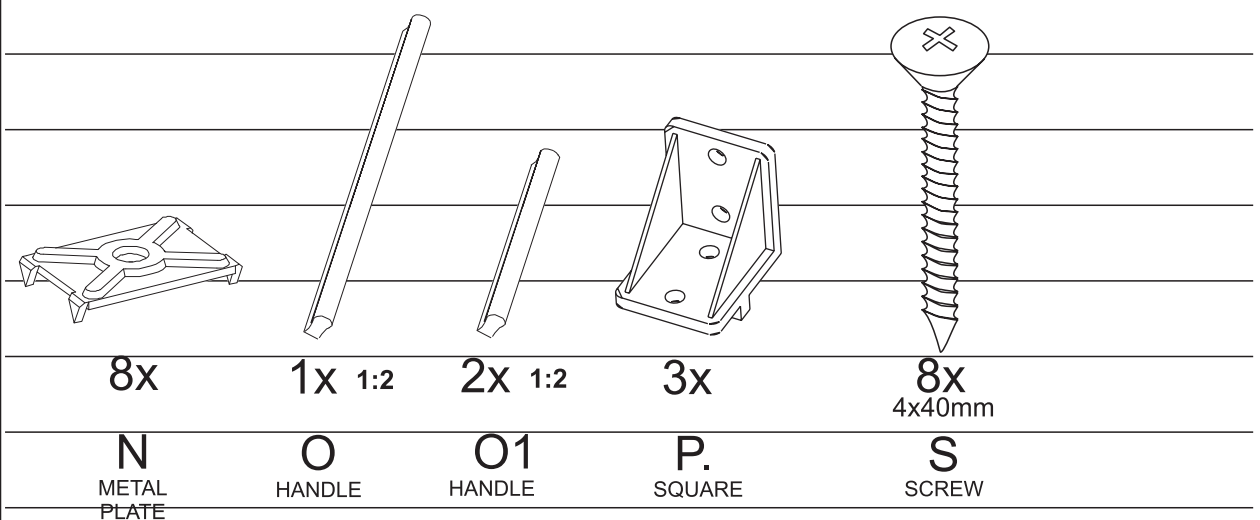
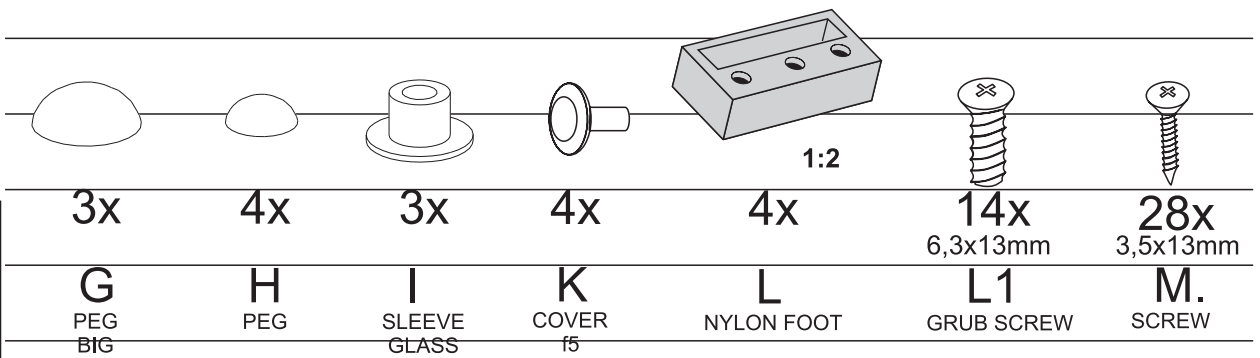
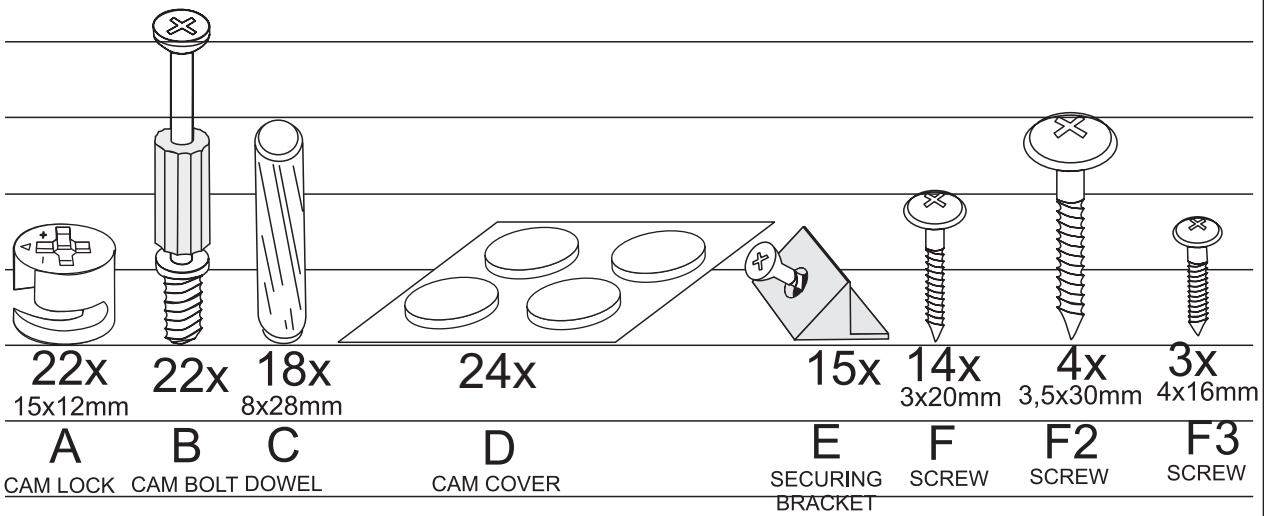

HARDWARE LIST

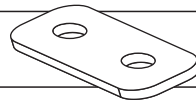

1x

Q
METAL
PLATE

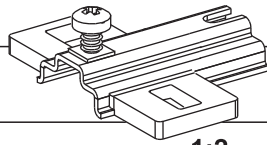

1:2

4x
H-2
V

HINGE PLATE

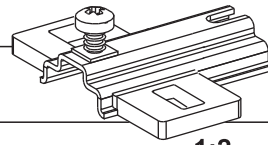

1:2

3x
H-2
V

HINGE PLATE

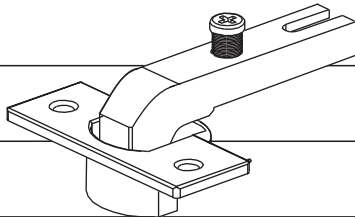

1:2

4x
90°
W
HINGE

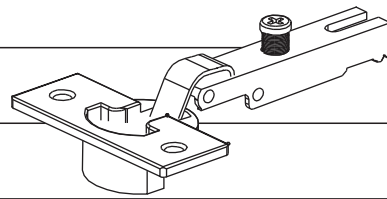

1:2

3x
kr0
W1
HINGE

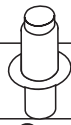

8x
5x16mm
Z
SHELF
SUPPORT

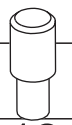

12x
5x16mm
Z1
SHELF GLASS
SUPPORT



2x
X
LEVEL QUOIN

1:2

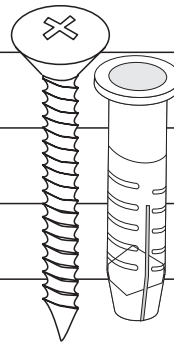

1x
4x35mm
R
PLASTIC
DOWEL

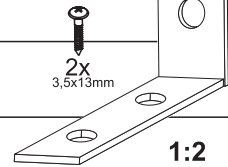

2x
3,5x13mm

1x
T
ANGLE

1:2

Top Tips before you start!

1. Please check that all parts are present before you start the assembly of your furniture, as once assembled, the furniture is exempt from our home approval policy.
2. For ease and speed of assembly, we recommend that before you commence each step of the assembly, that you identify all the parts required for that step.
3. For larger items, please ensure that you have sufficient space and people (as indicated on page 1) to assemble your product safely.
4. We recommend that, where possible, all items are assembled near to the area in which they will be placed in use, to avoid moving the product unnecessarily once assembled.
5. For the protection of your furniture, particularly items of high gloss finish, we recommend that the product is placed on a protected surface during assembly to prevent any damage.
6. During assembly please take care not to over-tighten any fittings, as this may damage the product .

Care and Maintenance of your Furniture

Please periodically check all fittings and re-tighten as necessary.

Please do not sit or stand on this item.

Never allow any kind of liquid to remain on your furniture. Absorption can cause wood to warp or finishes to de-laminate.

Please do not drag and pull your furniture.

SPECIAL TIPS FOR FITTING CAM-LOCKS AND CAM-PILLARS

CAM-LOCK



WHEN FITTING CAMS
ENSURE STARTING POSITION IS CORRECT
BEFORE YOU INSERT CONNECTING CAM-PILLAR
TURN CLOCKWISE UNTIL SECURE

✓ ✗

CORRECT WRONG

Align with long point of cross

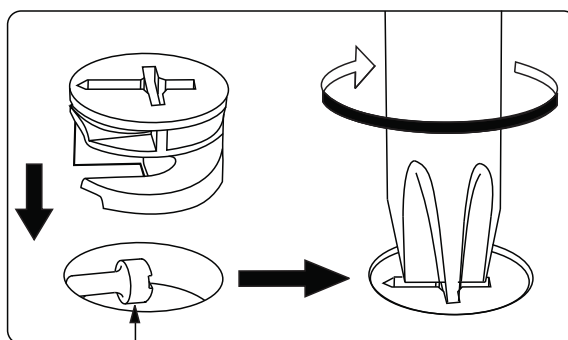





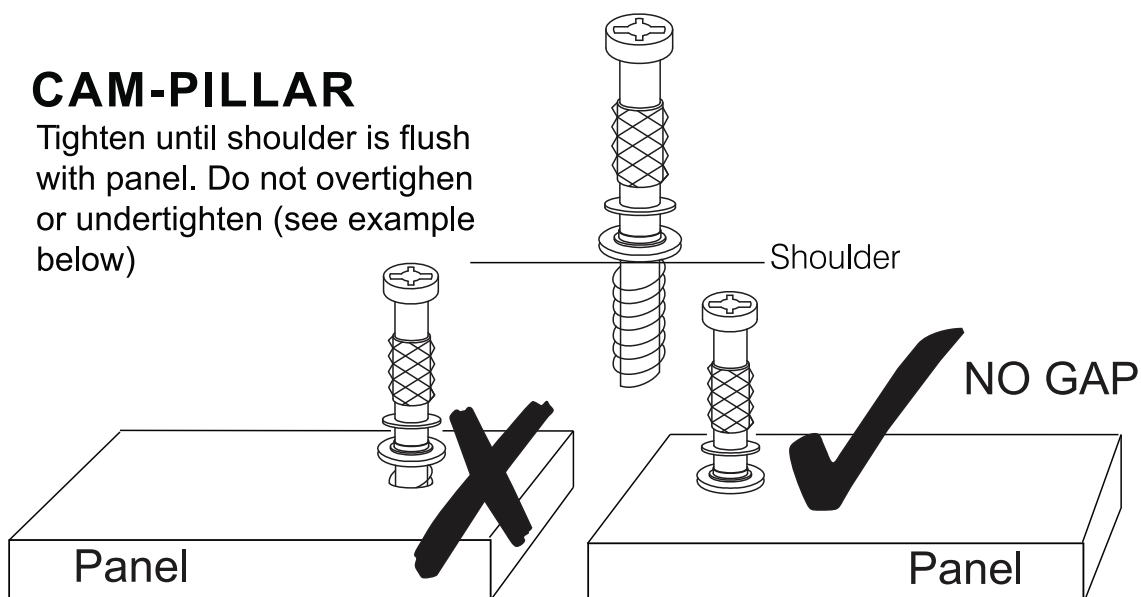

Pillar head needs to be in centre

CAM-PILLAR

Tighten until shoulder is flush with panel. Do not overtighten or undertighten (see example below)







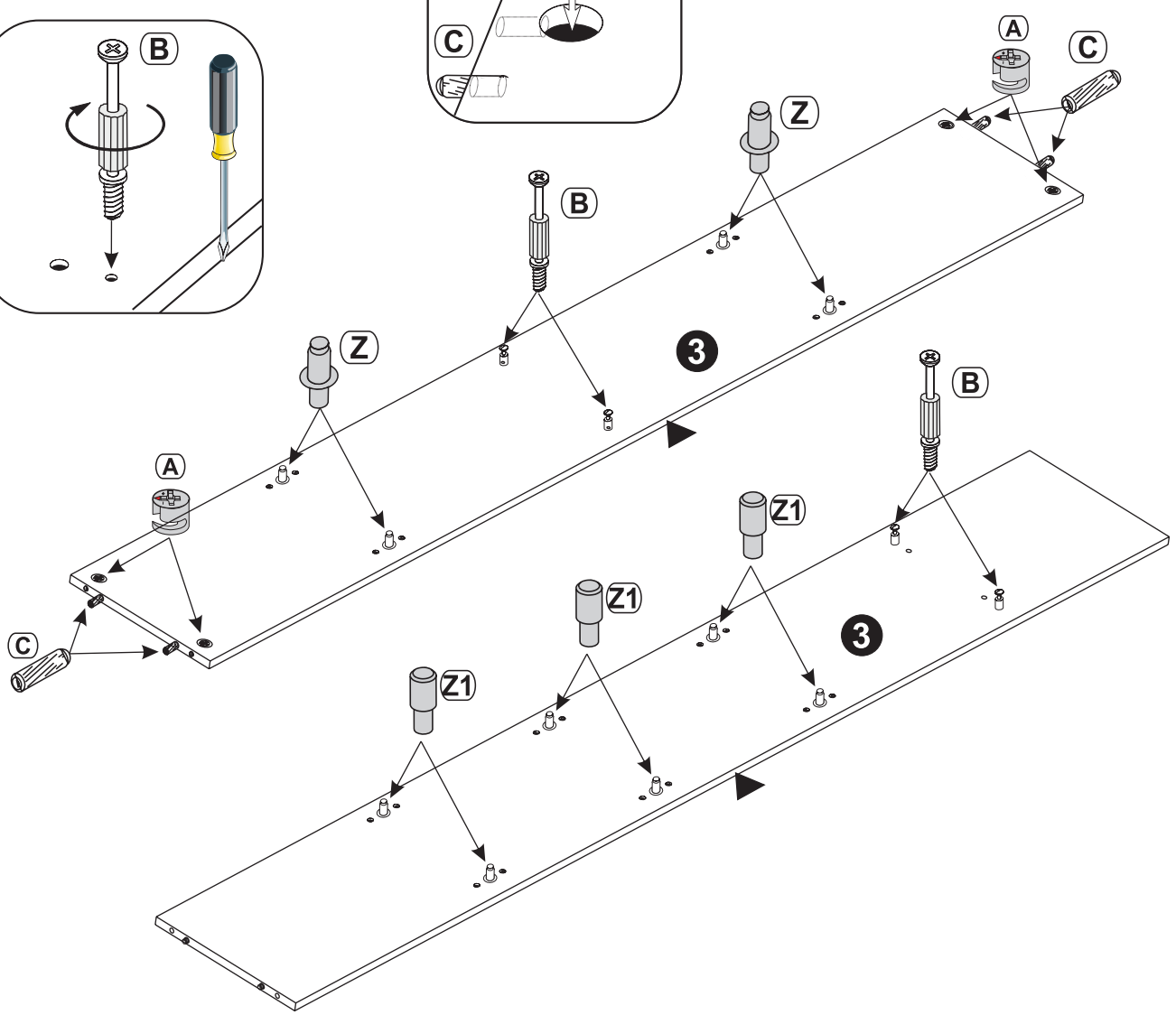
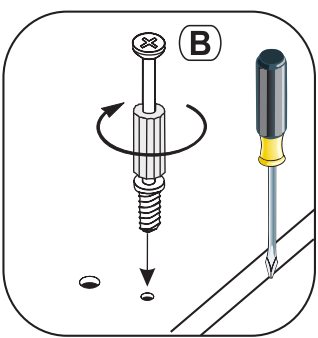
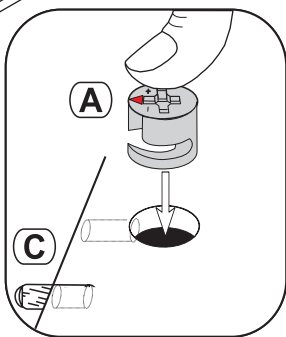
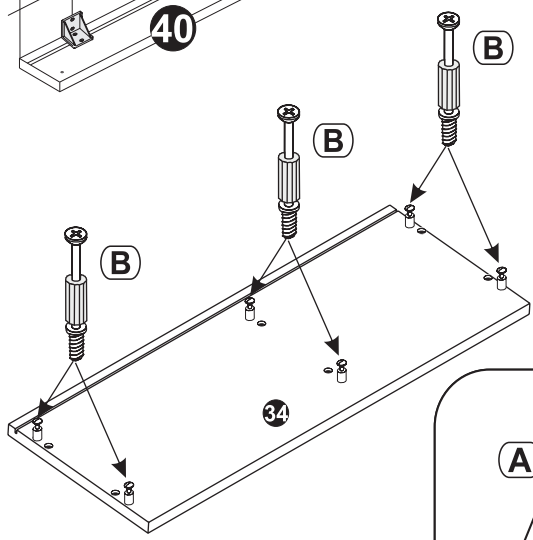
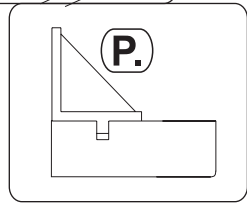
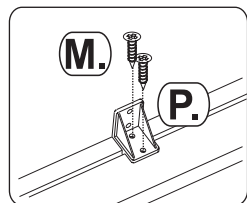
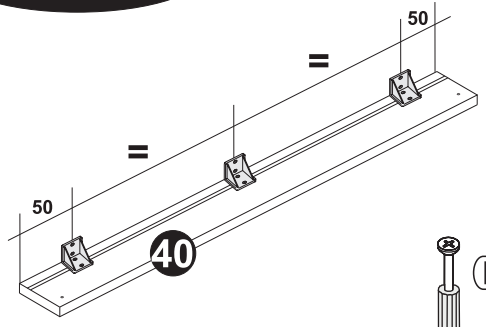

STEP 1

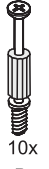
- 
 4x
 15x12mm
A
 CAM LOCK
- 
 10x
B
 CAM BOLT
- 
 4x
 8x28mm
C
 DOWEL
- 
 3x
P
 SQUARE
- 
 6x
 3,5x13mm
M
 SCREW
- 
 4x
 5x16mm
Z
 SHELF SUPPORT
- 
 6x
 5x18mm
Z1
 SHELF GLASS SUPPORT



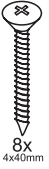
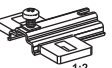

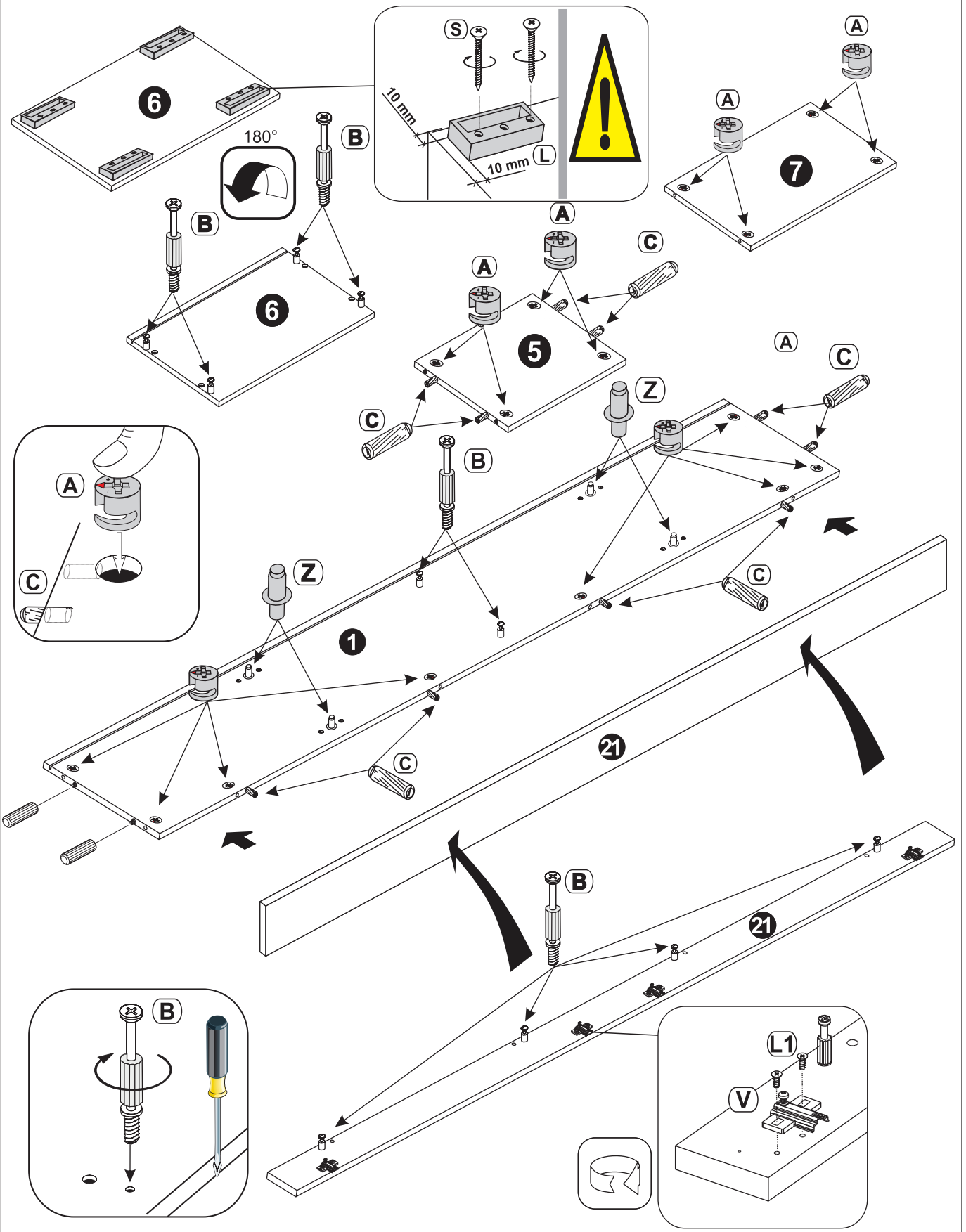

STEP 2

-  16x
15x12mm
A
CAM LOCK
-  10x
B
CAM BOLT
-  12x
8x28mm
C
DOWEL
-  4x
1:2
L
NYLON FOOT
-  8x
6,3x13mm
L1
GRUB SCREW
-  8x
4x40mm
S
SCREW
-  4x
H-2
V
HINGE PLATE
-  4x
5x16mm
Z
SHELF SUPPORT



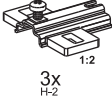

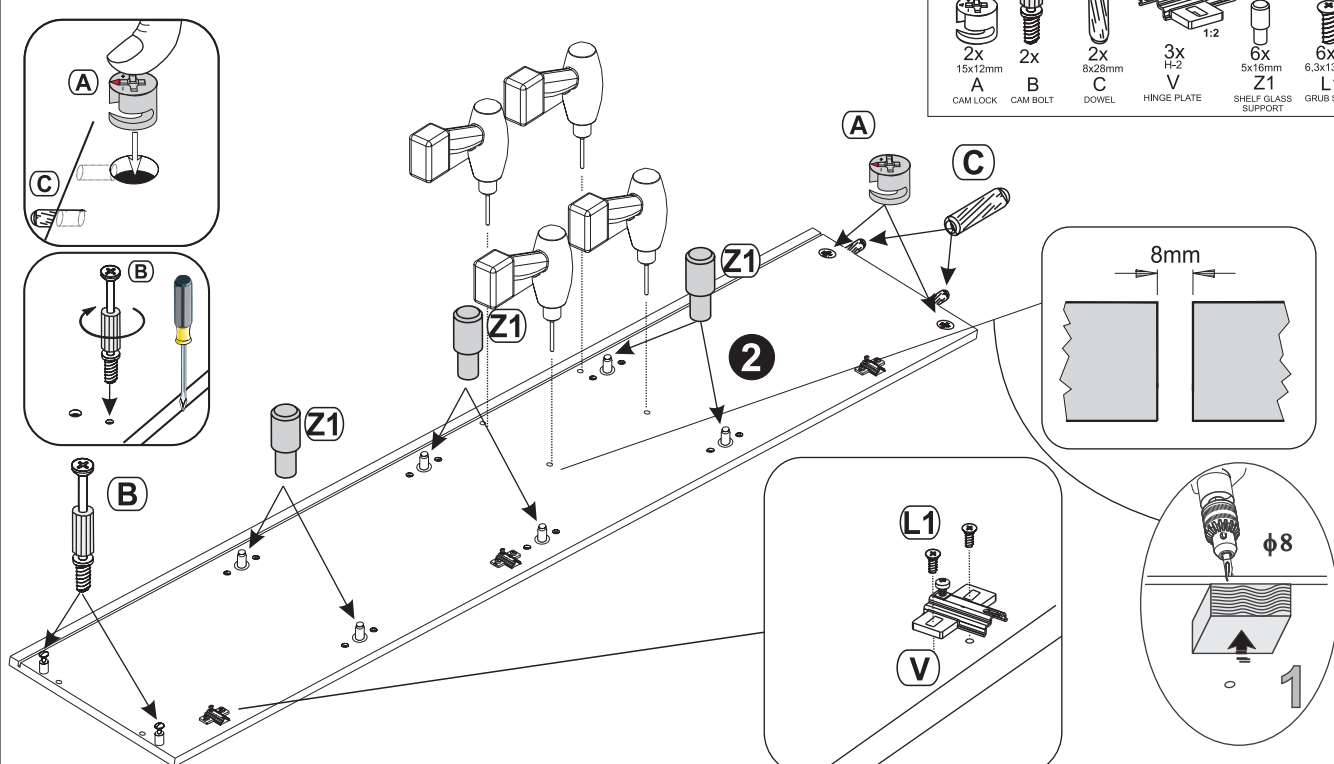

STEP 3

-  2x 15x12mm
A CAM LOCK
-  2x
B CAM BOLT
-  2x 8x28mm
C DOWEL
-  3x H-2
V HINGE PLATE
-  6x 5x16mm
Z1 SHELF GLASS SUPPORT
-  6x 6.3x13mm
L1 GRUB SCREW

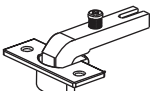
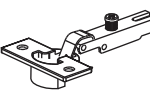

STEP 4

-  3x 4x16mm
F3 SCREW
-  3x
I SLEEVE GLASS
-  14x 3,5x13mm
M. SCREW
-  1x 1:2
O HANDLE
-  4x 90°
W HINGE
-  3x
W1 HINGE

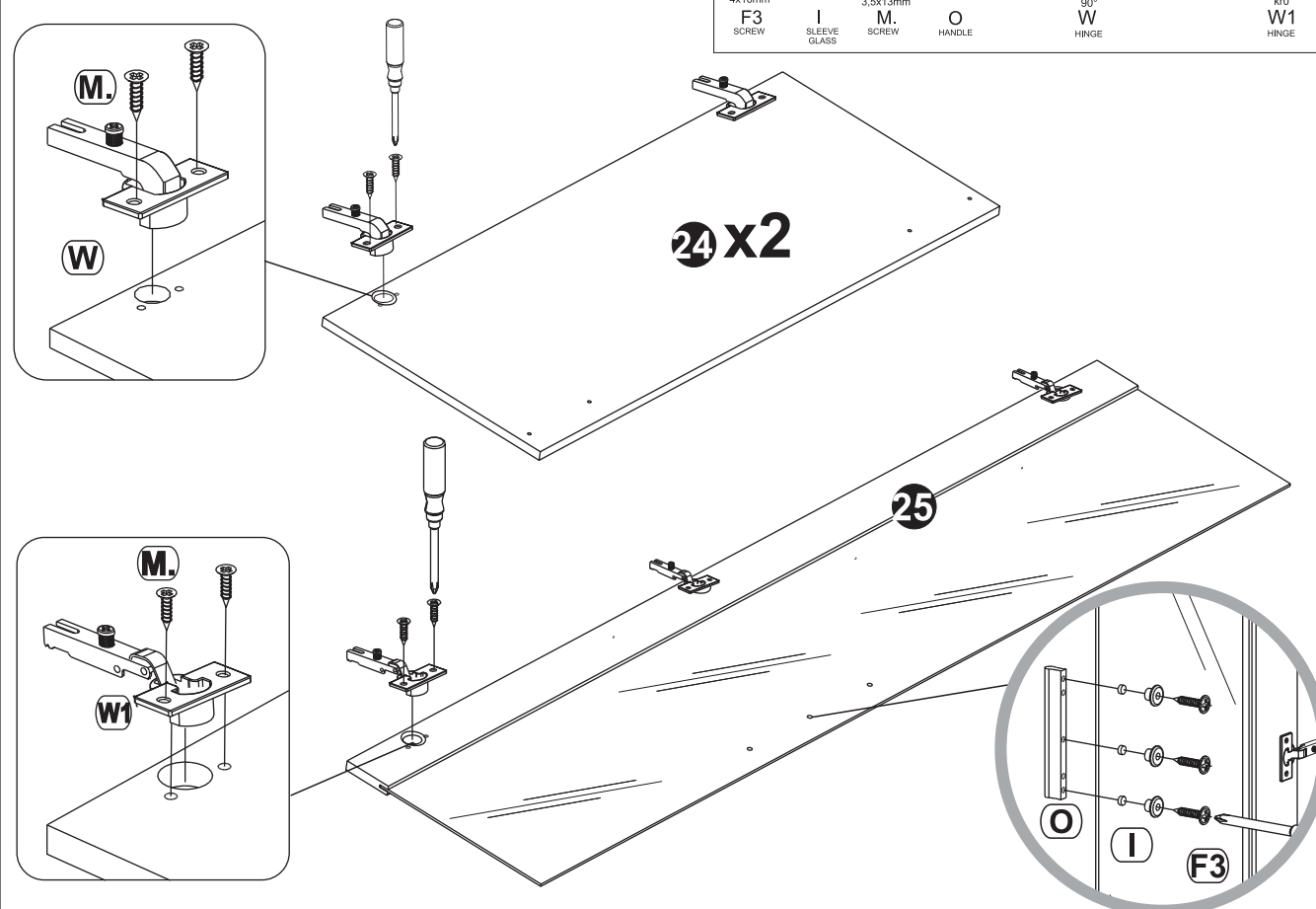

STEP 5

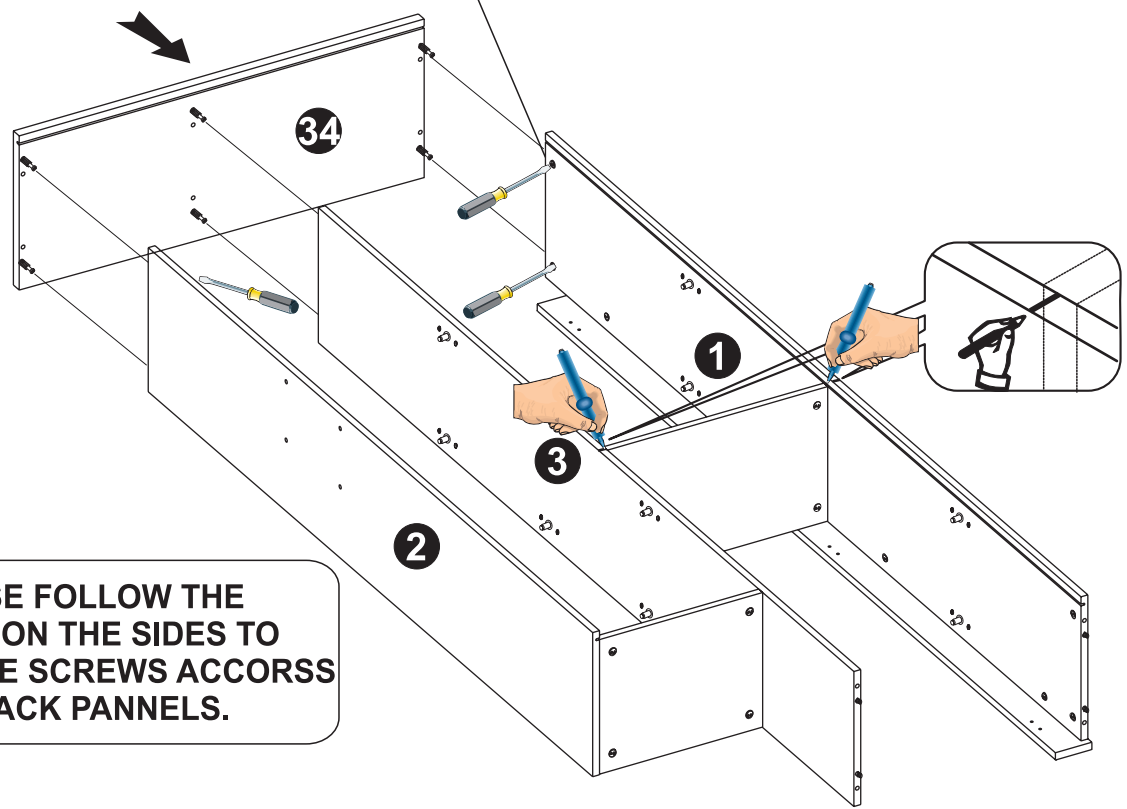
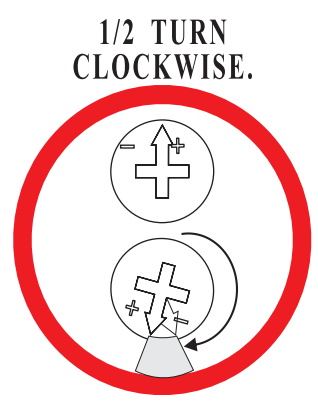
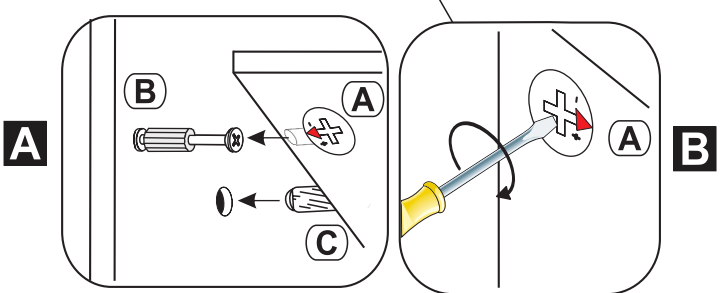
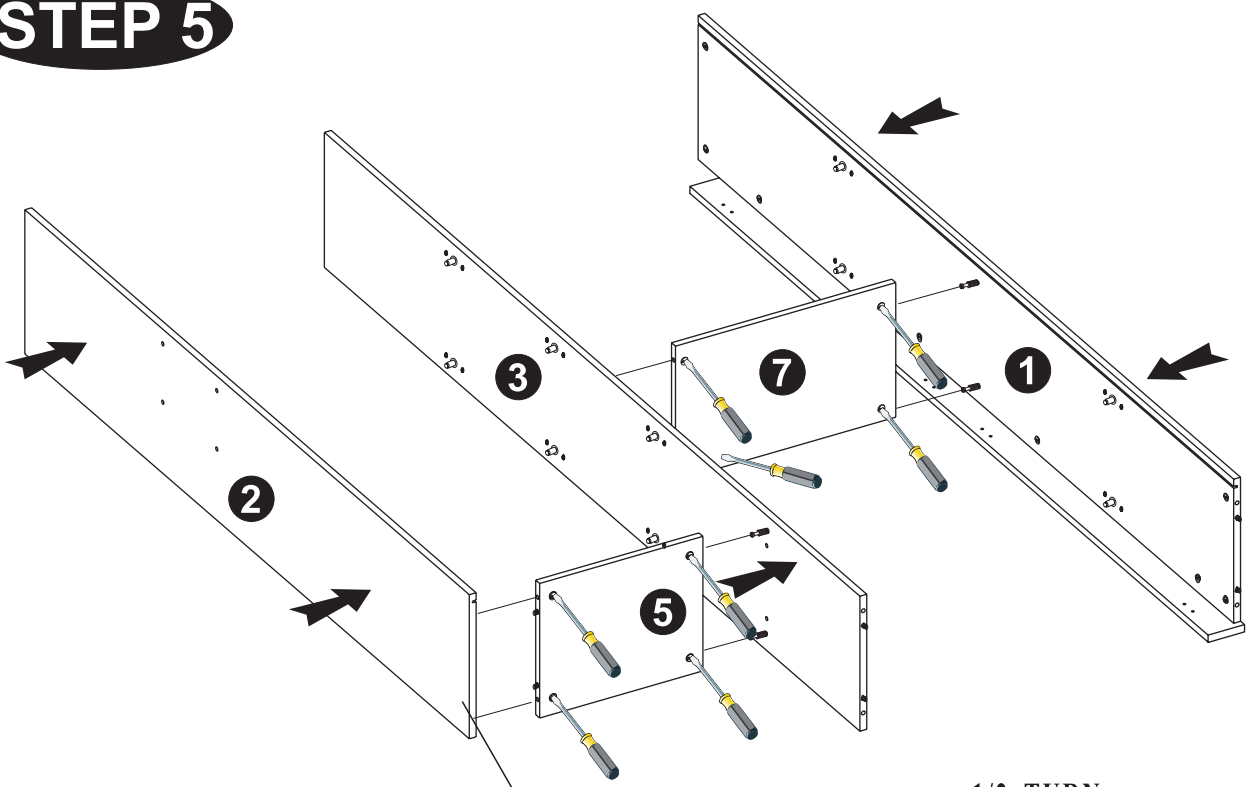

PLEASE FOLLOW THE MARK ON THE SIDES TO FIX THE SCREWS ACCROSS THE BACK PANNELS.

STEP 6

- 15x E SECURING BRACKET
- 14x 3x20mm F SCREW
- 8x N METAL PLATE

1/2 TURN CLOCKWISE.

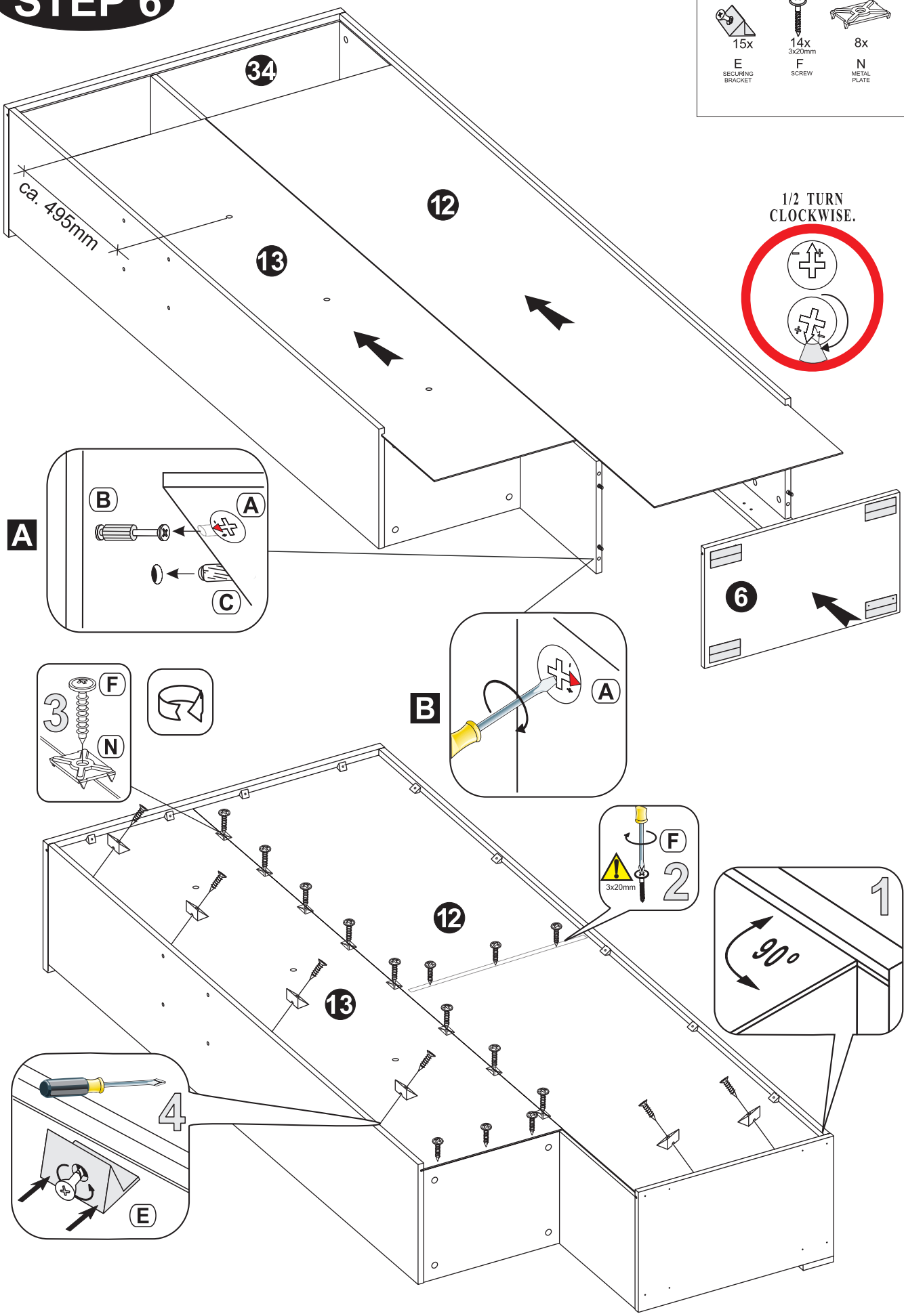
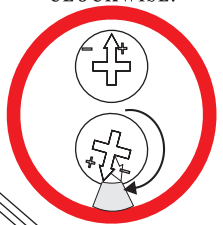

STEP 7

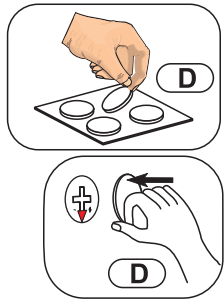

- | | | | | | | | |
|-----------------------|------------------------|-------------------------------|-----------------------|----------------|-------------------------------|------------------------|------------------------|
| | | | | | | | |
| 22x
D
CAM COVER | 1x
Q
METAL PLATE | 4x
3.5x30mm
F2
SCREW | 3x
G
PEG
BIG | 4x
H
PEG | 8x
3.5x13mm
M.
SCREW | 2x 1:2
O1
HANDLE | 2x
X
LEVEL GUIDE |

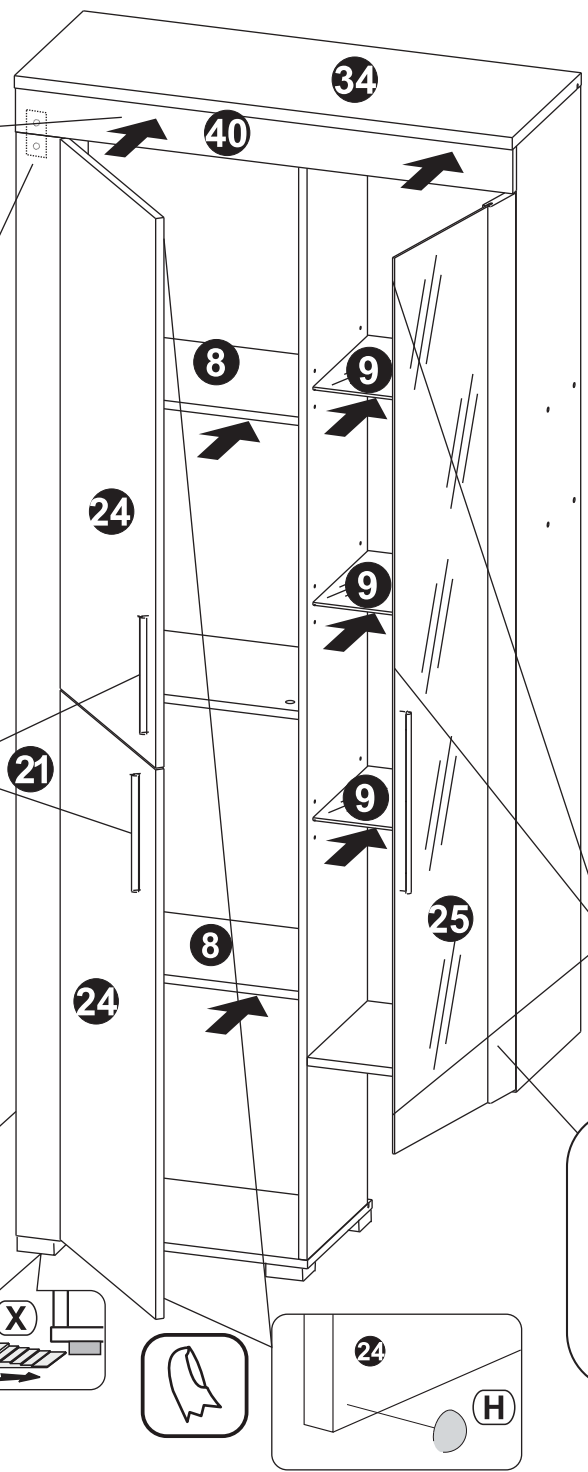
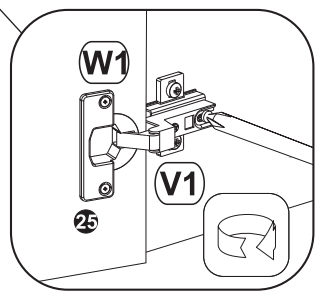
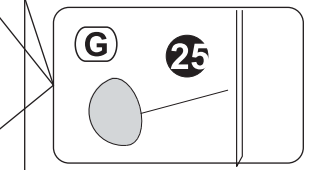
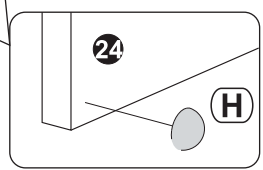
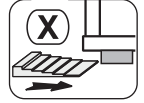
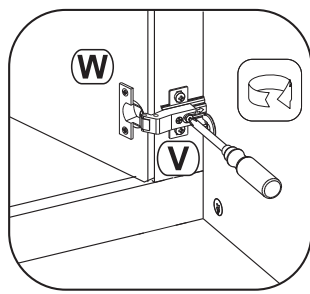
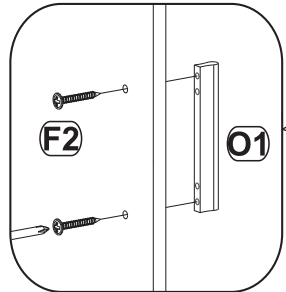
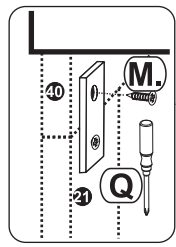
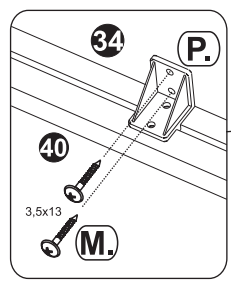

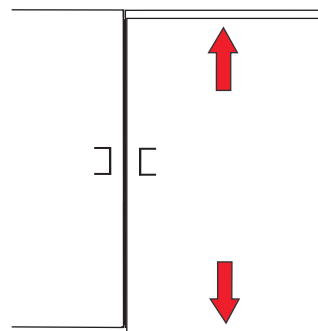
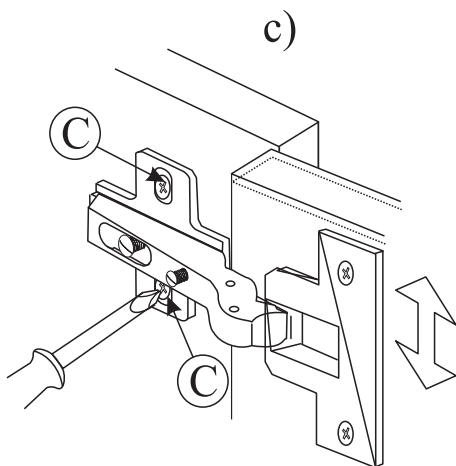
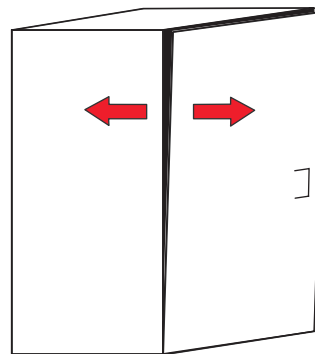
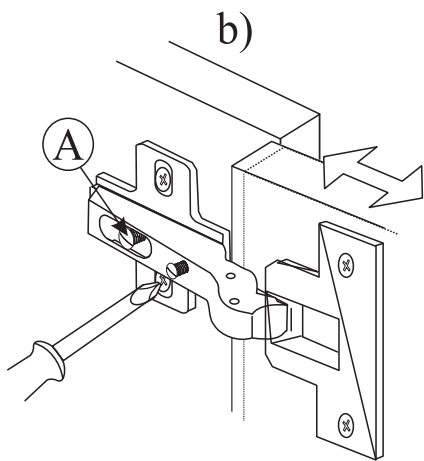
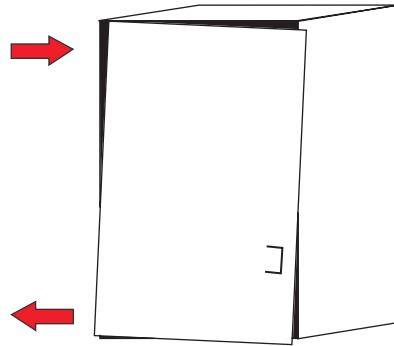
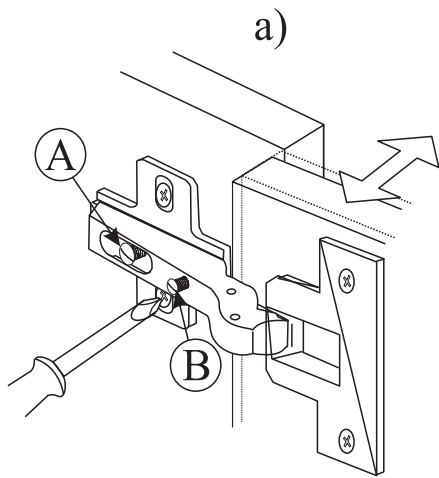

LED Lights in type 319

STEP 8

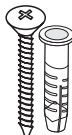

STEP 9

-  1x
4x35mm
R
PLASTIC
DOWEL
-  1x
1:2
T
ANGLE
-  4x
K
COVER
IS

