

ASSEMBLY INSTRUCTION

DESCRIPTION: Type 037 BOOM P6--BH/BOOM GRANDE P6--BG

2.5 hrs

APPROXIMATE ASSEMBLY TIME
EXCLUDING GLUE SETTING TIME

2 PERSON ASSEMBLY



FLOOR AREA
2,5M X 2,5M

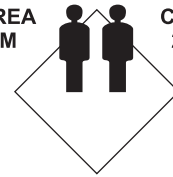

CEILING HEIGHT
2,0M

REQUIRED ASSEMBLY SPACE

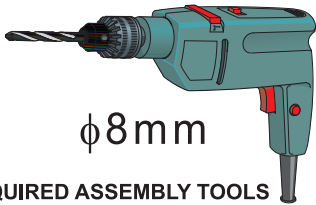

$\phi 8\text{mm}$

REQUIRED ASSEMBLY TOOLS

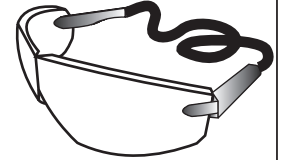
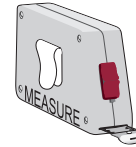

ASSEMBLED DIMENSIONS

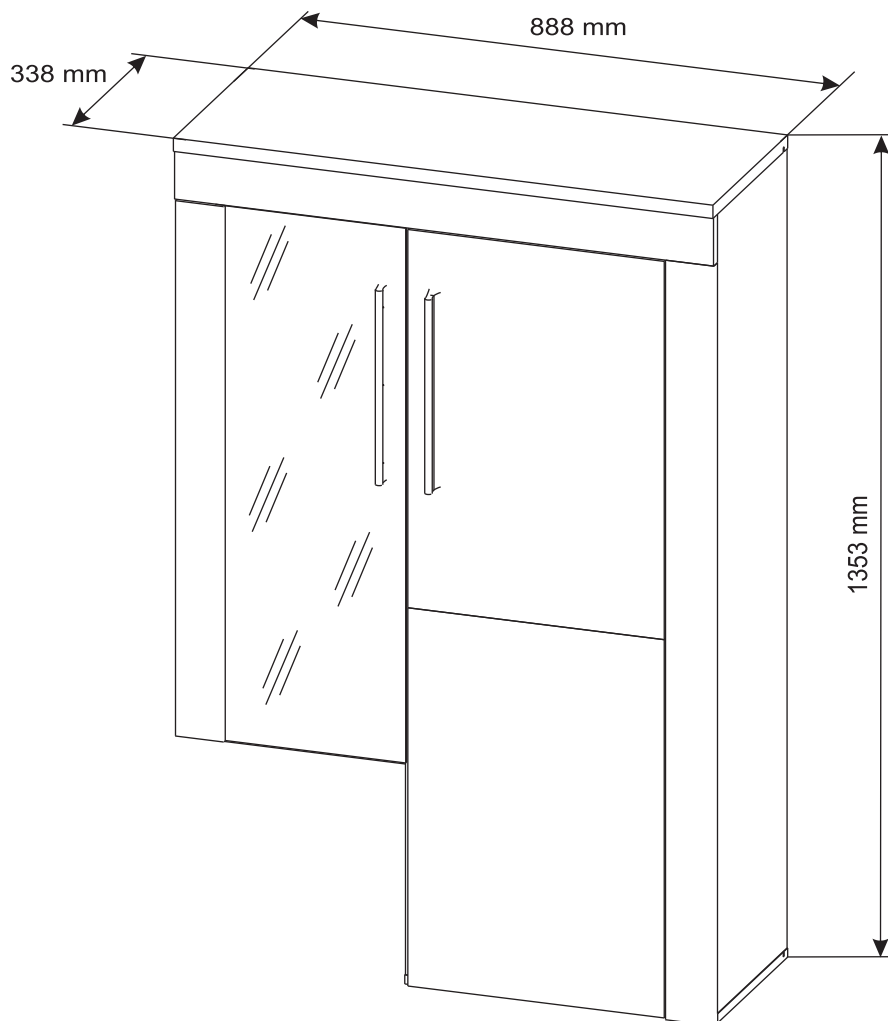

PART LIST

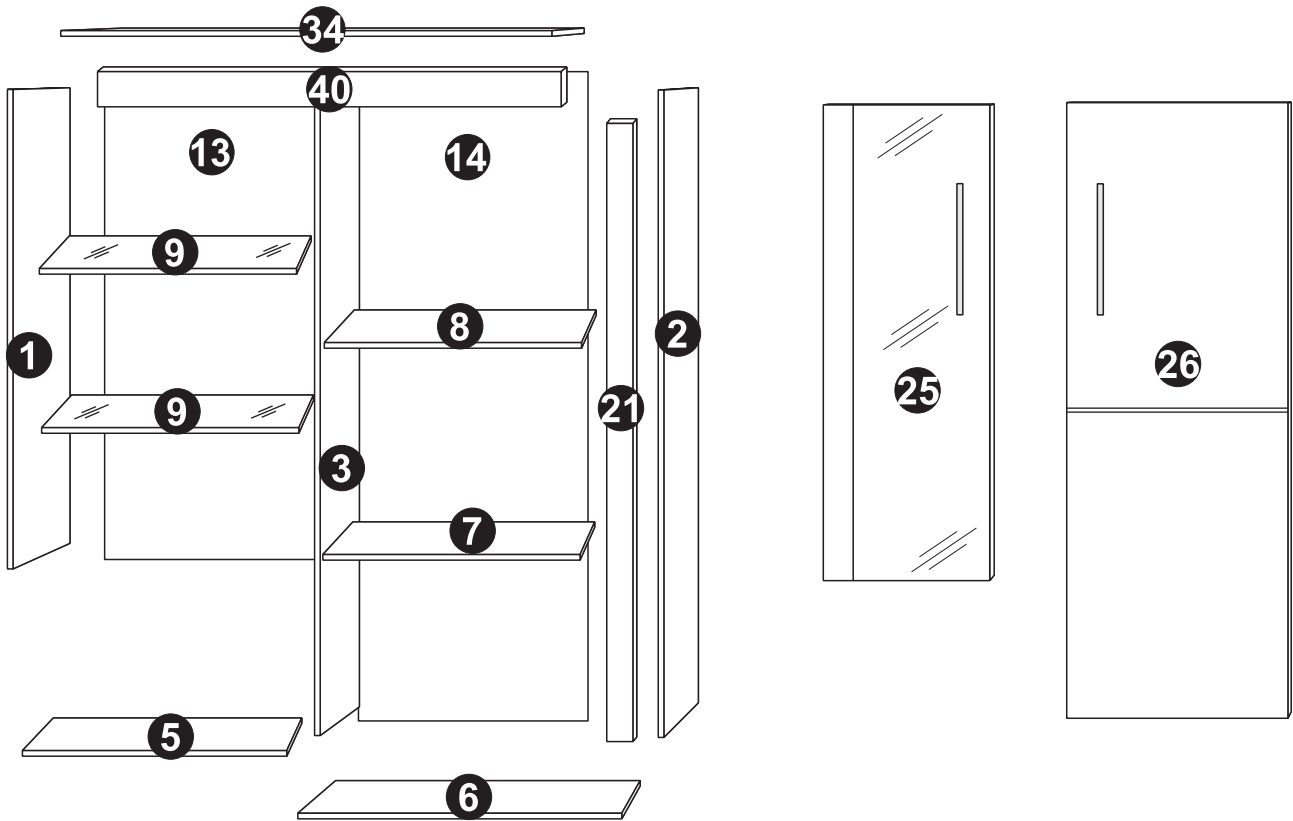

NO. PARTS LIST	QTY	NO. PARTS LIST	QTY
(1) LEFT SIDE PANEL	1	(25) LEFT DOOR W/GLASS	1
(2) RIGHT SIDE PANEL	1	(26) RIGHT DOOR	1
(3) CENTER DIVIDER	1	(40) PLINTH	1
(34) TOP PANEL	1		
(5) HORIZONTAL DIVIDER	1		
(6) BOTTOM PANEL	1		
(7) RIGHT HORIZONTAL DIVIDER	1		
(8) SHELF	1		
(9) SHELF GLASS	2		
(13) LEFT BACK PANEL	1		
(14) RIGHT BACK PANEL	1		
(21) RIGHT PLINTH			

HARDWARE LIST

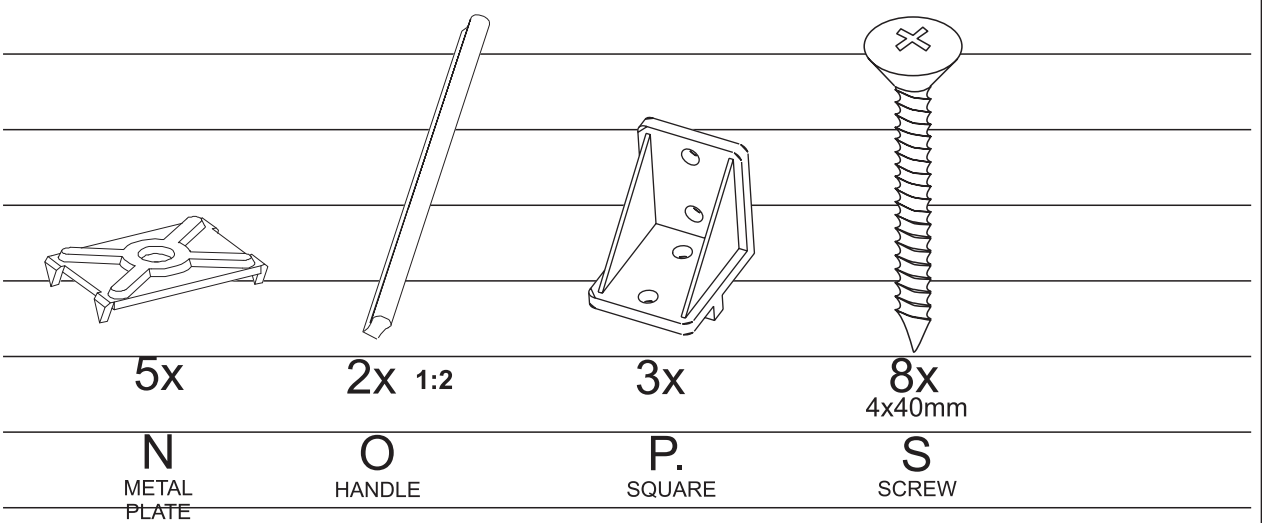
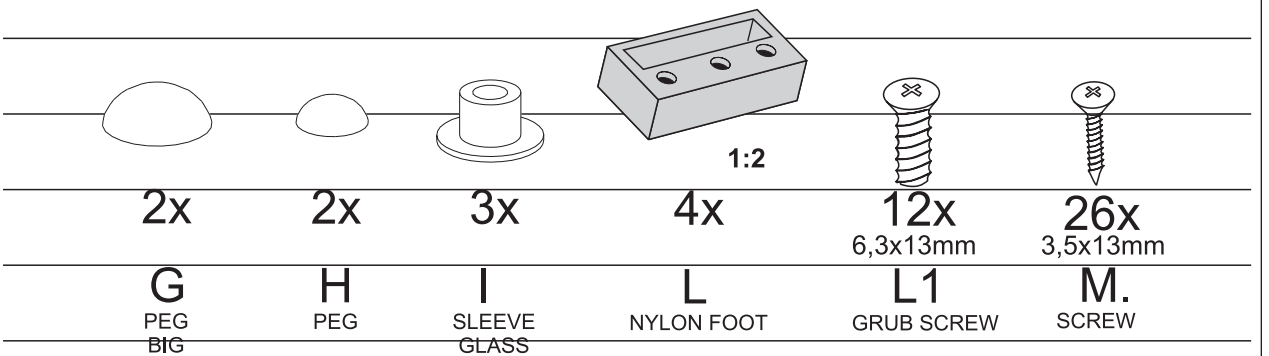
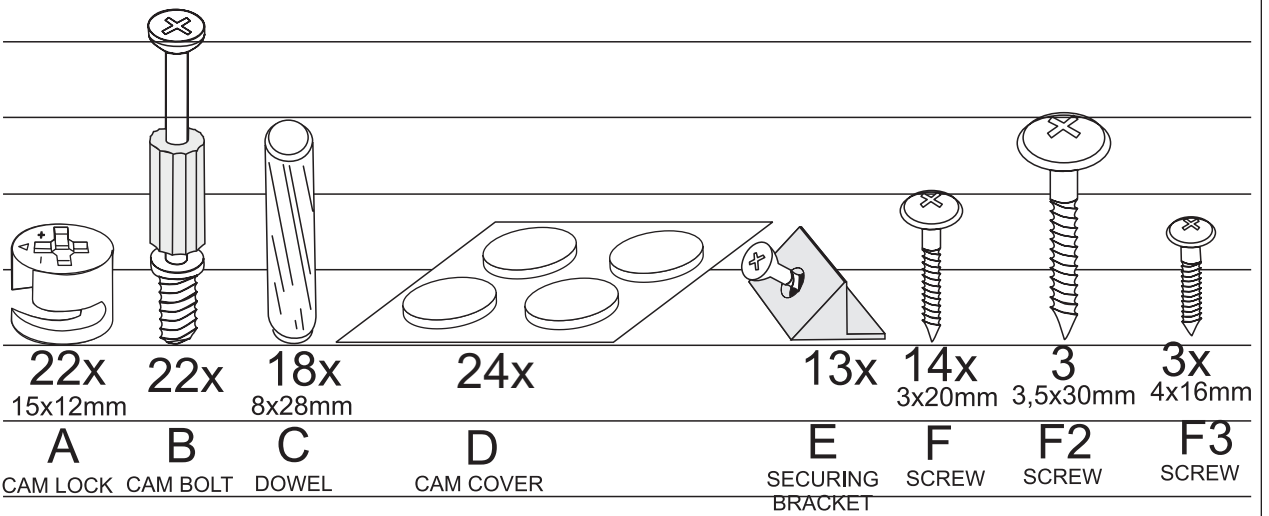

HARDWARE LIST

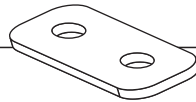

1x

Q
METAL
PLATE

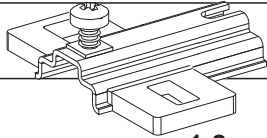

1:2

4x
H-2

V

HINGE PLATE

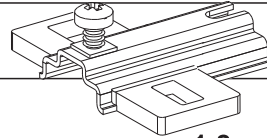

1:2

2x
H-2

V

HINGE PLATE

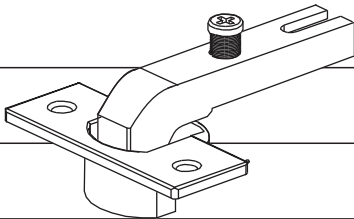

1:2

4x
90°

W

HINGE

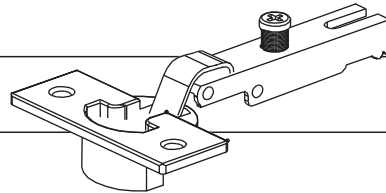

1:2

2x
kr0

W1

HINGE

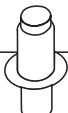

4x
5x16mm

Z

SHELF
SUPPORT



8x
5x16mm

Z1

SHELF GLASS
SUPPORT



1:2

2x

X

LEVEL QUOIN

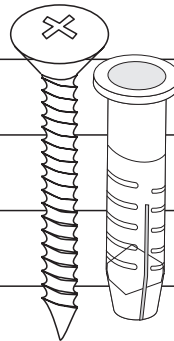

1x
4x35mm

R

PLASTIC
DOWEL

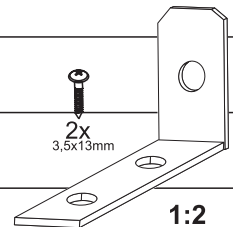

2x
3,5x13mm

1:2

1x

T

ANGLE

Top Tips before you start!

1. Please check that all parts are present before you start the assembly of your furniture, as once assembled, the furniture is exempt from our home approval policy.
2. For ease and speed of assembly, we recommend that before you commence each step of the assembly, that you identify all the parts required for that step.
3. For larger items, please ensure that you have sufficient space and people (as indicated on page 1) to assemble your product safely.
4. We recommend that, where possible, all items are assembled near to the area in which they will be placed in use, to avoid moving the product unnecessarily once assembled.
5. For the protection of your furniture, particularly items of high gloss finish, we recommend that the product is placed on a protected surface during assembly to prevent any damage.
6. During assembly please take care not to over-tighten any fittings, as this may damage the product .

Care and Maintenance of your Furniture

Please periodically check all fittings and re-tighten as necessary.

Please do not sit or stand on this item.

Never allow any kind of liquid to remain on your furniture. Absorption can cause wood to warp or finishes to de-laminate.

Please do not drag and pull your furniture.

SPECIAL TIPS FOR FITTING CAM-LOCKS AND CAM-PILLARS

CAM-LOCK

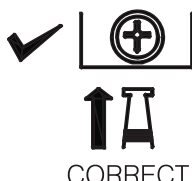
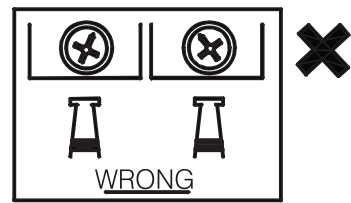

WHEN FITTING CAMS
ENSURE STARTING POSITION IS CORRECT
BEFORE YOU INSERT CONNECTING CAM-PILLAR
TURN CLOCKWISE UNTIL SECURE

Align with long point of cross

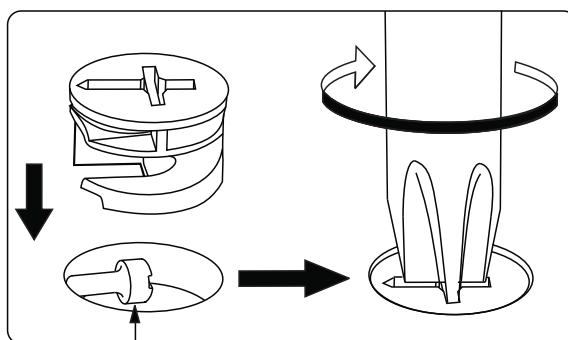

Pillar head needs to be in centre





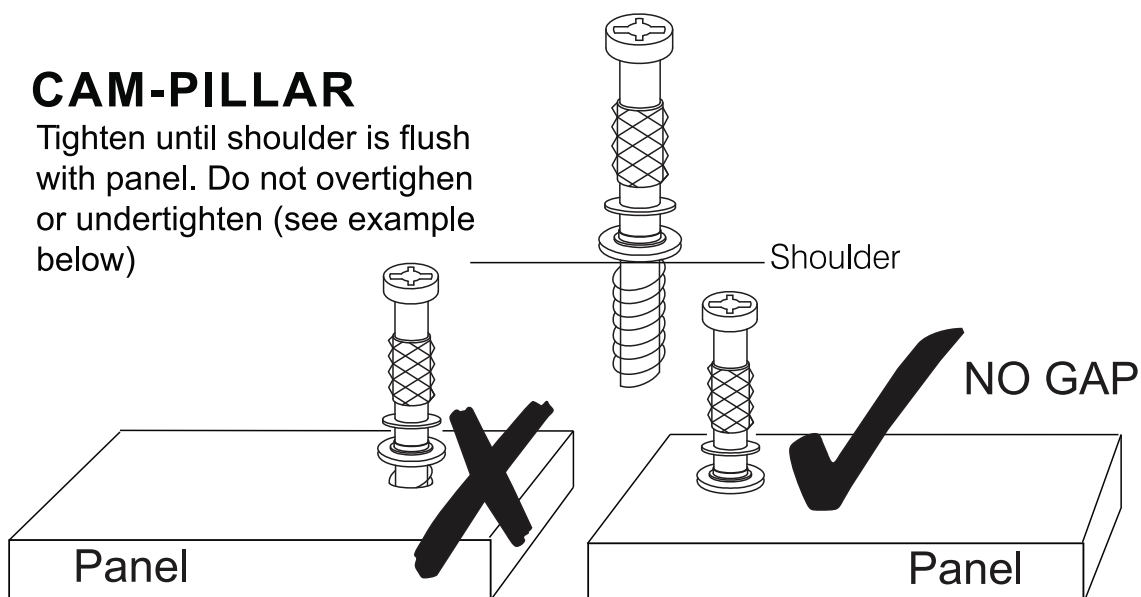

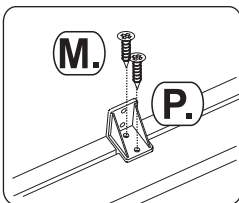

CAM-PILLAR

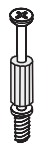
Tighten until shoulder is flush with panel. Do not overtighten or undertighten (see example below)

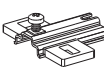







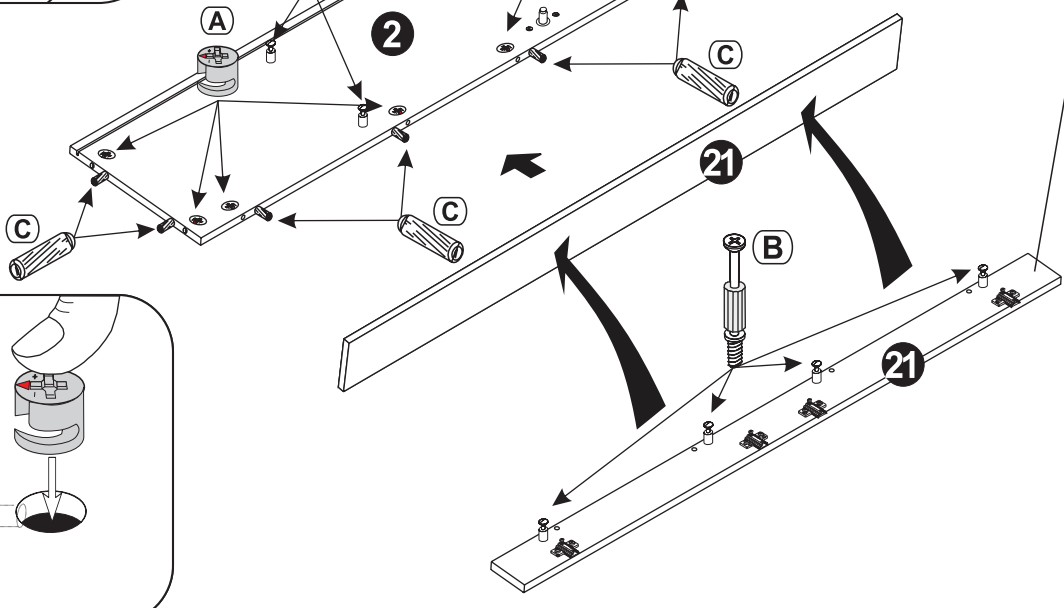
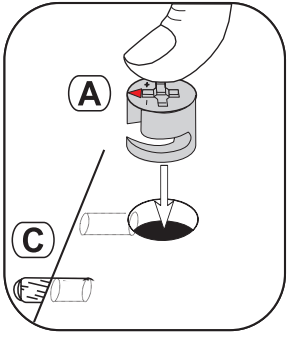
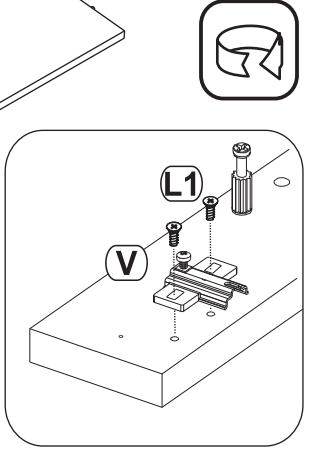
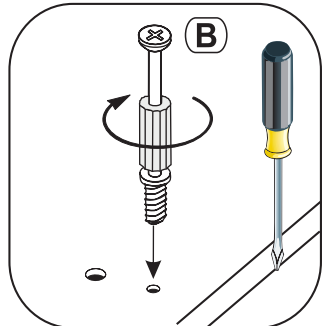
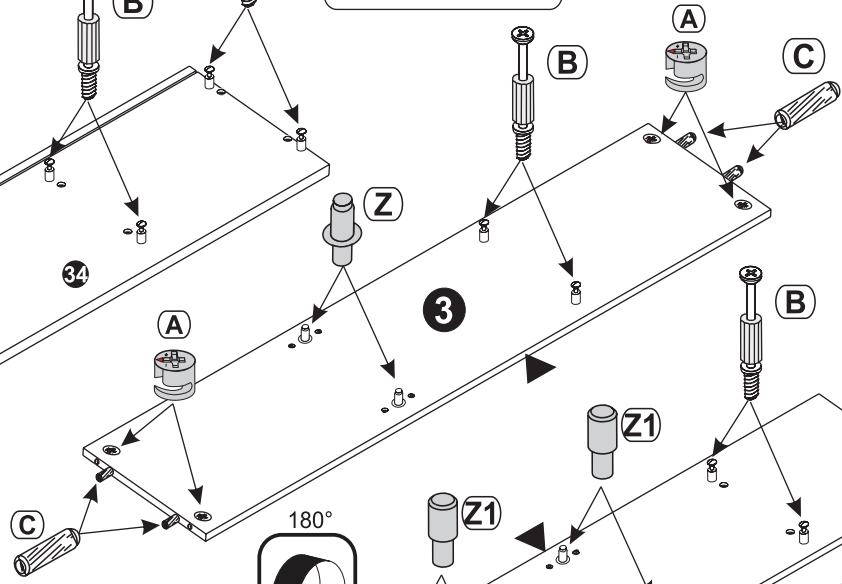
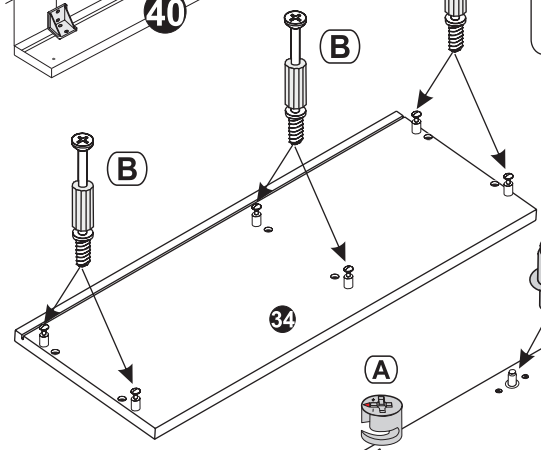
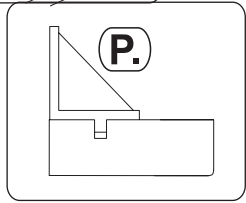
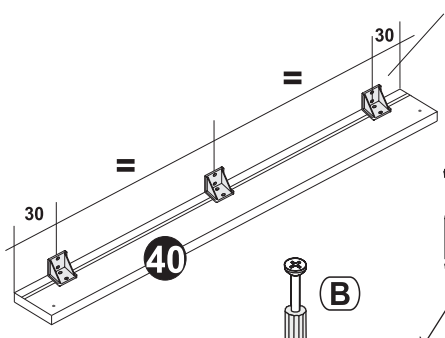

STEP 1



-  12x 15x12mm CAM LOCK A
-  16x CAM BOLT B
-  12x 8x28mm DOWEL C
-  4x H-4 V HINGE PLATE
-  3x SQUARE P
-  6x 3,5x13mm SCREW M
-  8x 6,3x13mm GRUB SCREW L1
-  4x 5x16mm Z SHELF SUPPORT
-  4x 5x16mm Z1 SHELF GLASS SUPPORT



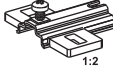

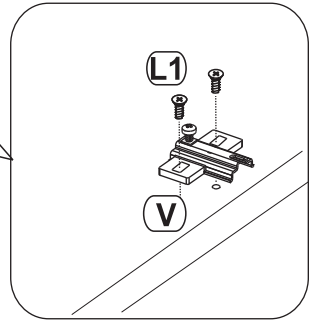
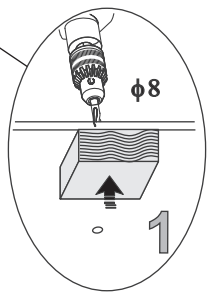
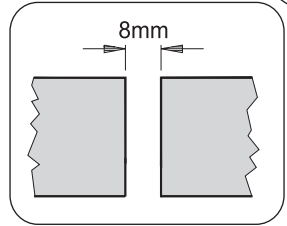
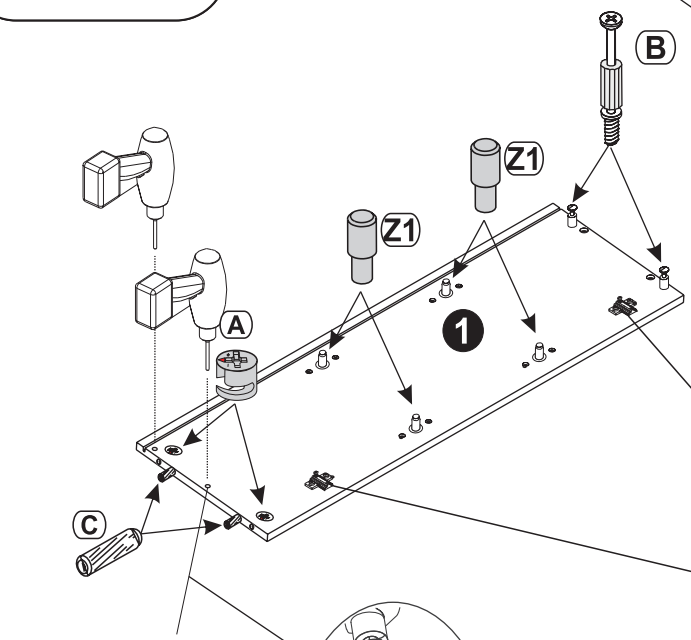
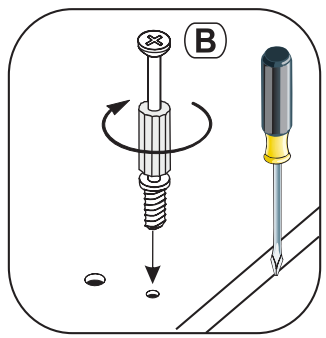
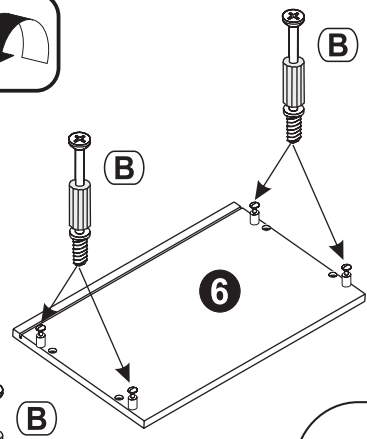
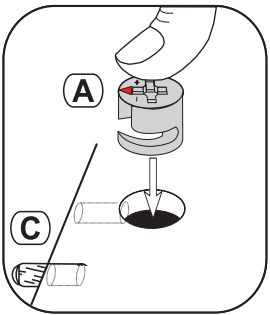
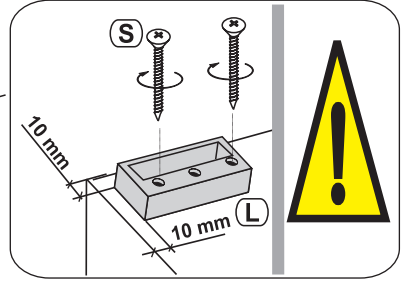
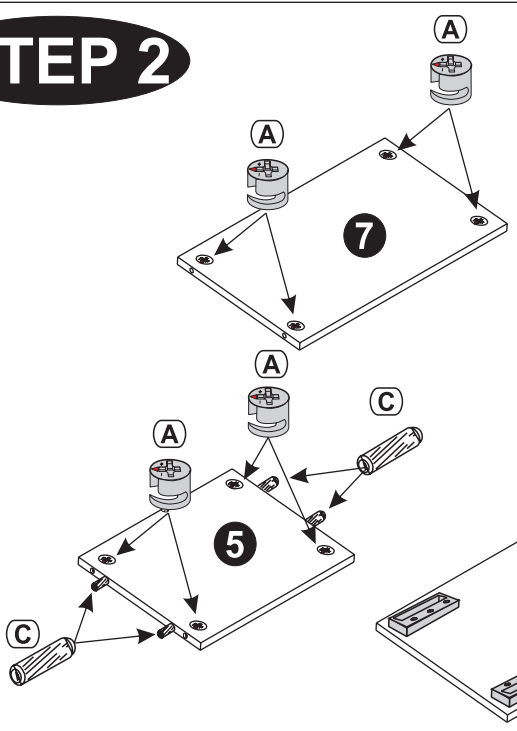

STEP 2

-  10x 15x12mm
A CAM LOCK
-  6x
B CAM BOLT
-  6x 8x28mm
C DOWEL
-  4x
L NYLON FOOT
-  4x 6.3x13mm
L1 GRUB SCREW
-  8x 4x40mm
S SCREW
-  2x 1:2
V HINGE PLATE
-  4x 5x16mm
Z1 SHELF GLASS SUPPORT



STEP 3

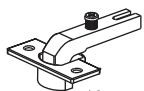
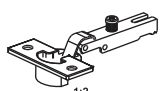

-  3x 3,5x30mm F2 SCREW
-  3x 4x16mm F3 SCREW
-  3x I SLEEVE GLASS
-  12x 3,5x13mm M. SCREW
-  2x 1:2 O HANDLE
-  4x 1:2 W HINGE
-  2x 1:2 W1 HINGE

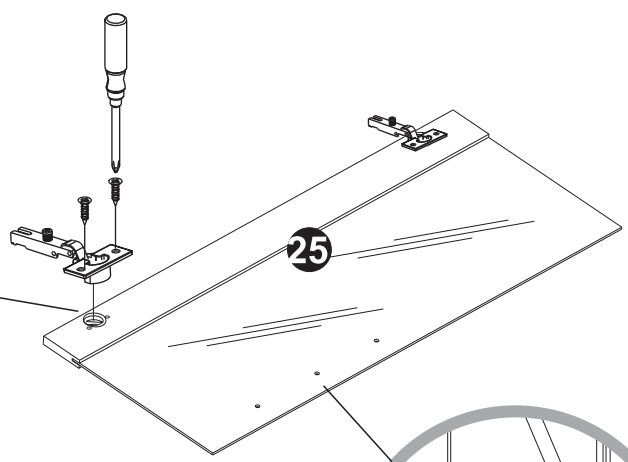
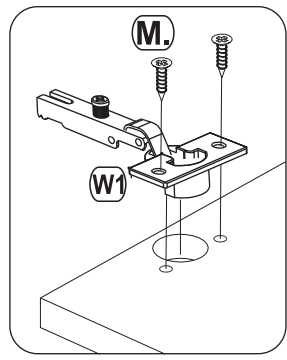
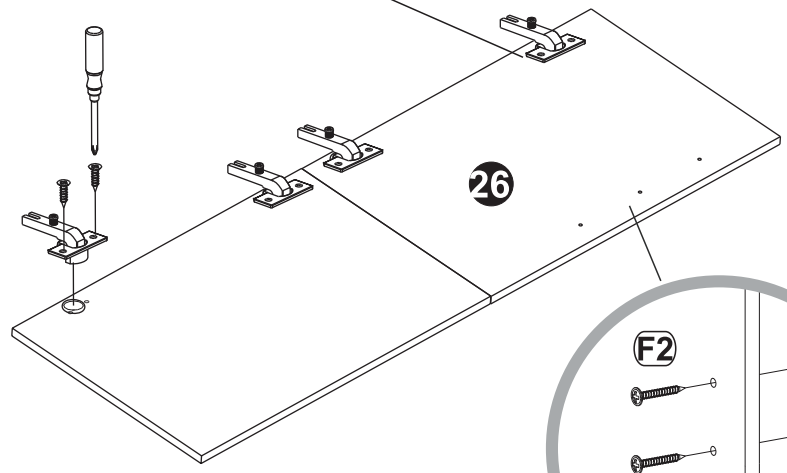
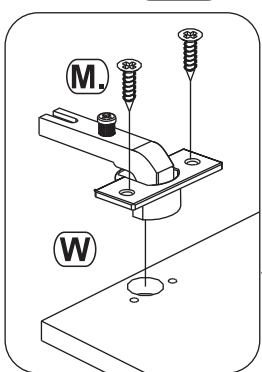

STEP 4

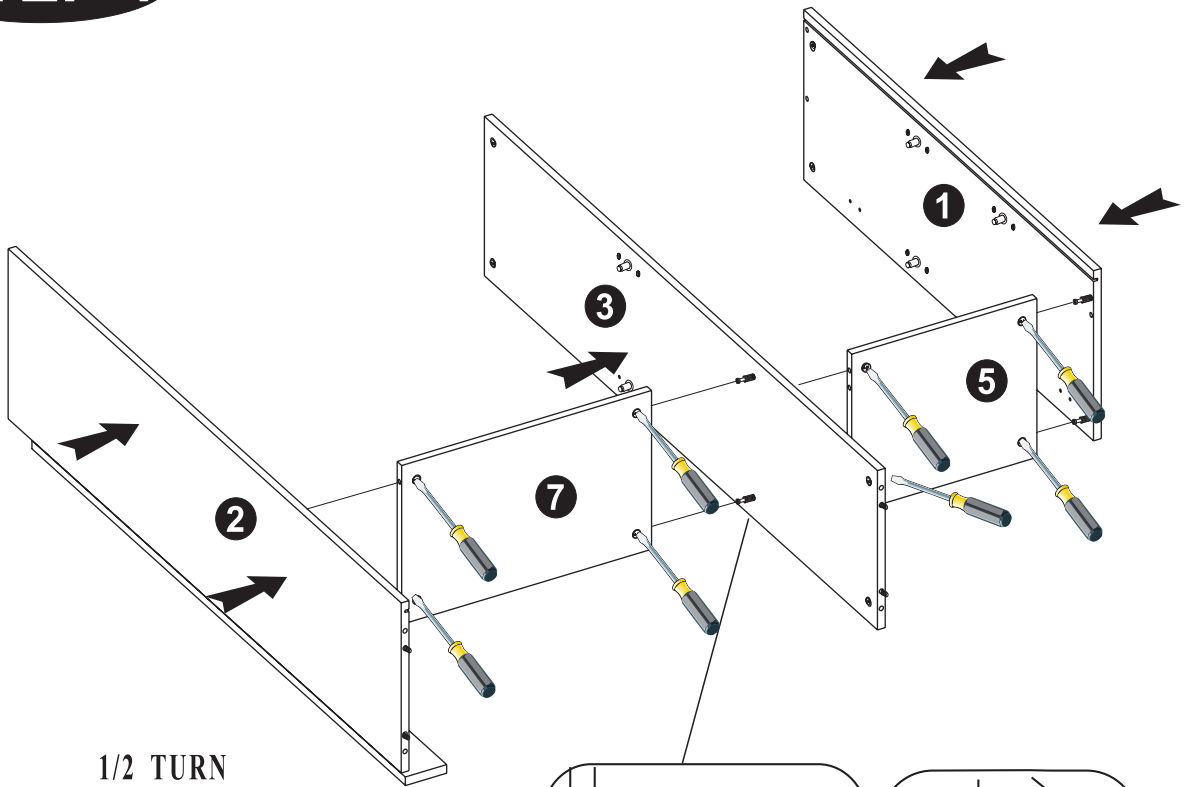

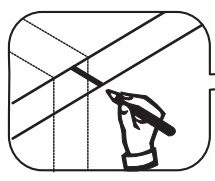
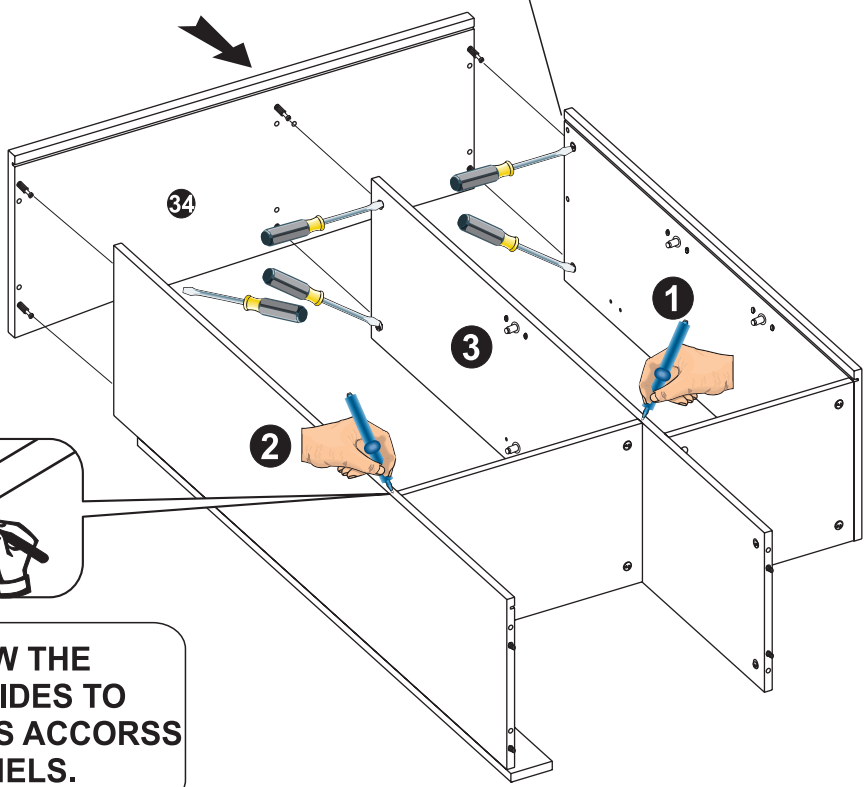
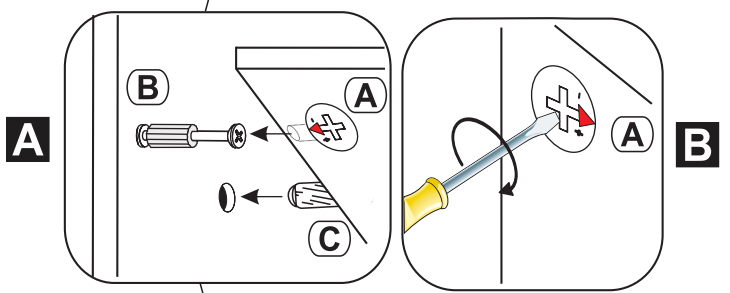
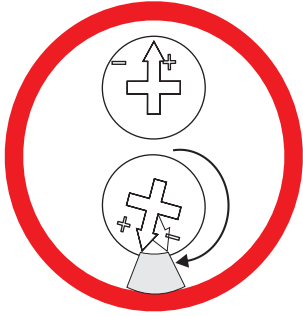

1/2 TURN
CLOCKWISE.







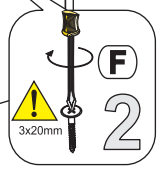
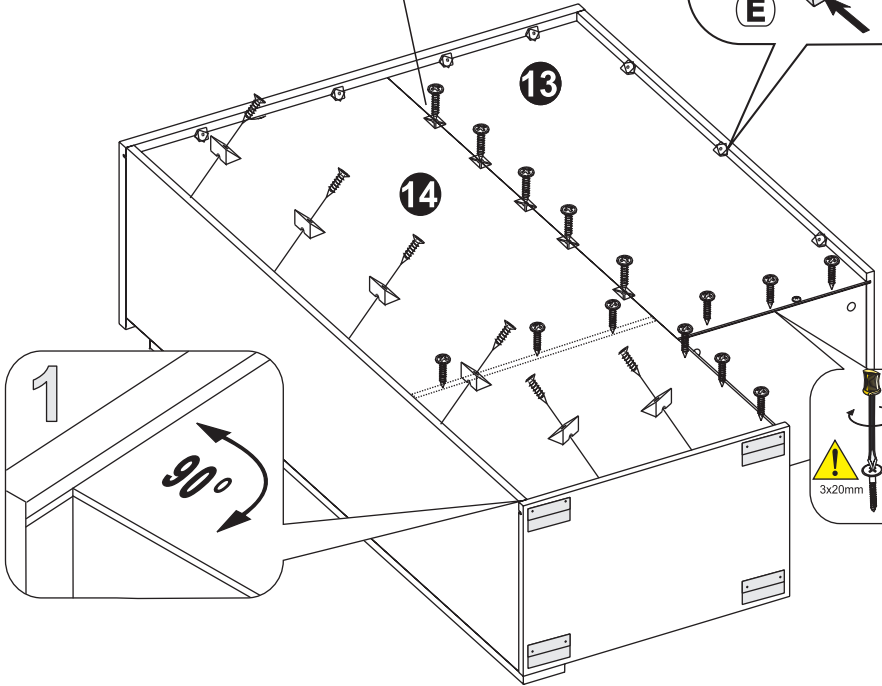
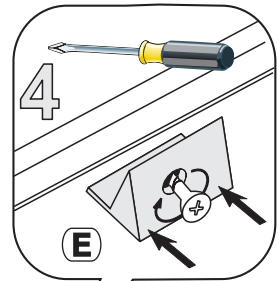
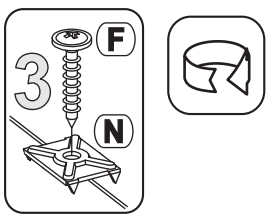
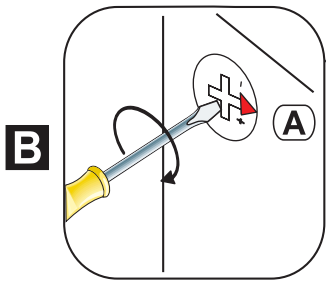
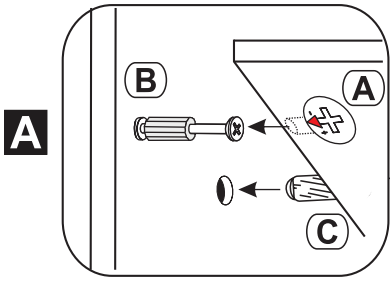
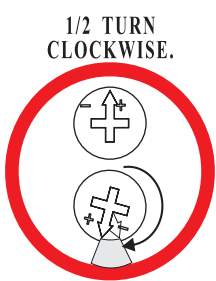
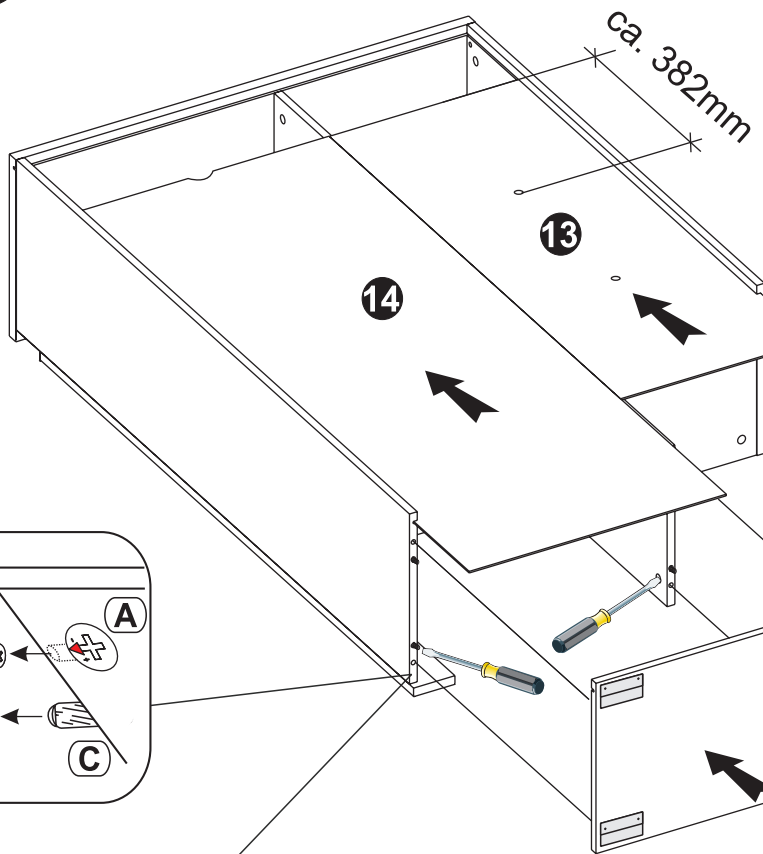

PLEASE FOLLOW THE
MARK ON THE SIDES TO
FIX THE SCREWS ACCROSS
THE BACK PANNELS.

STEP 5

		
13x	14x 3x20mm	5x
E SECURING BRACKET	F SCREW	N METAL PLATE



STEP 6

						1:2
22x	1x	2x	2x	8x 3,5x13mm	2x	
D CAM COVER	Q METAL PLATE	G PEG BIG	H PEG	M. SCREW	X LEVEL QUOIN	

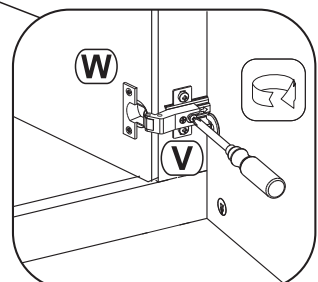
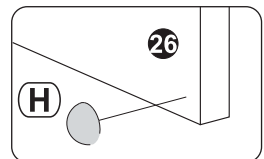
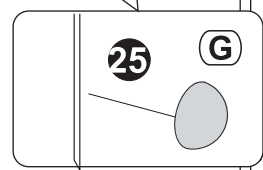
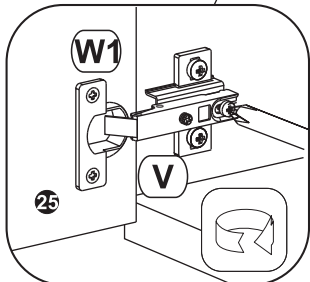
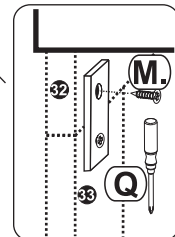
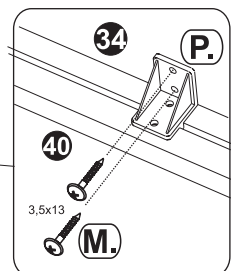
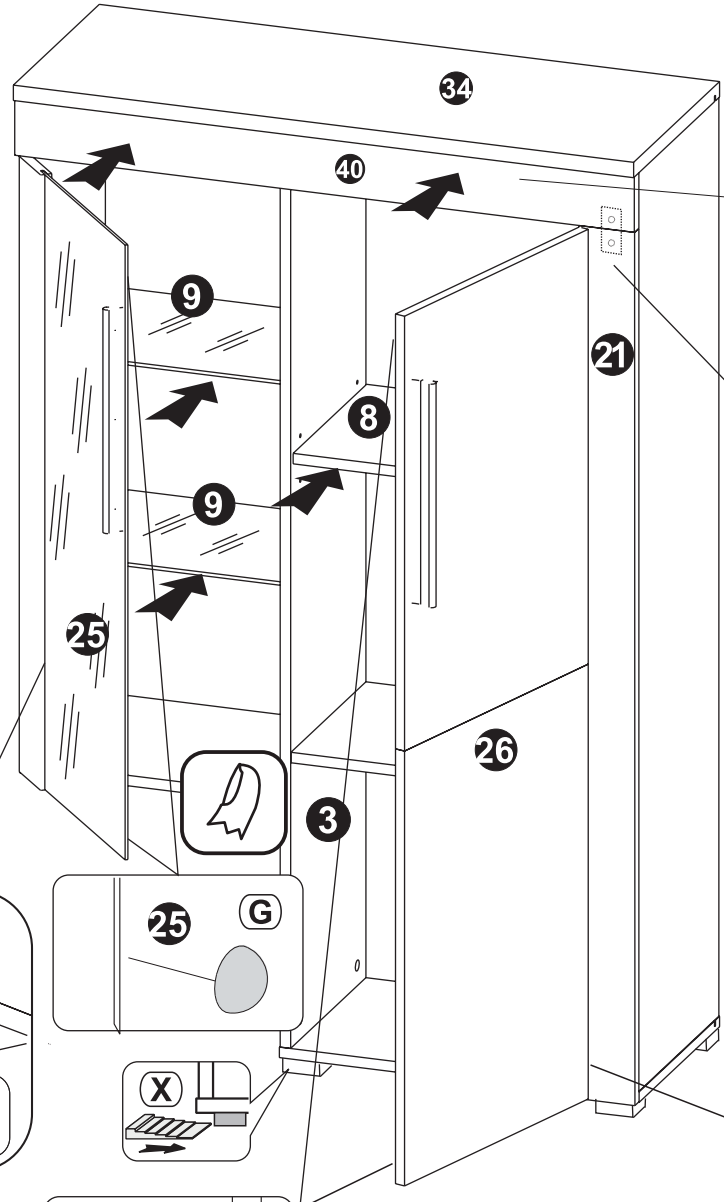
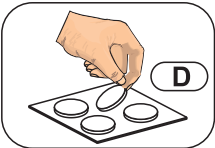

 LED Lights in type 319

STEP 7

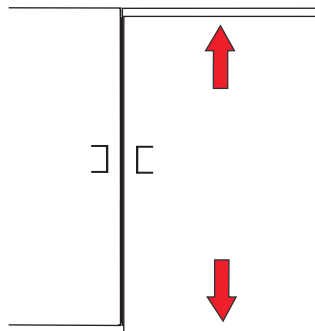
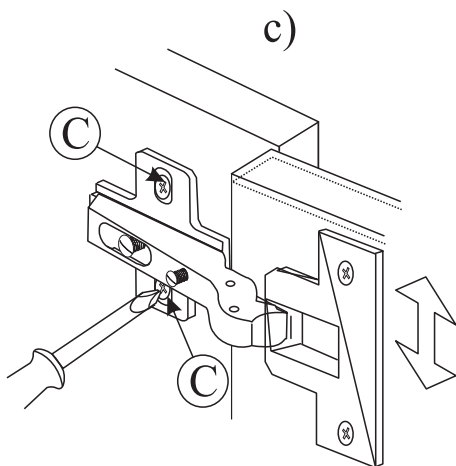
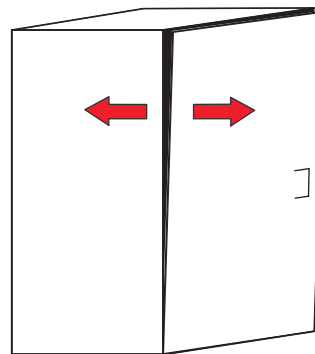
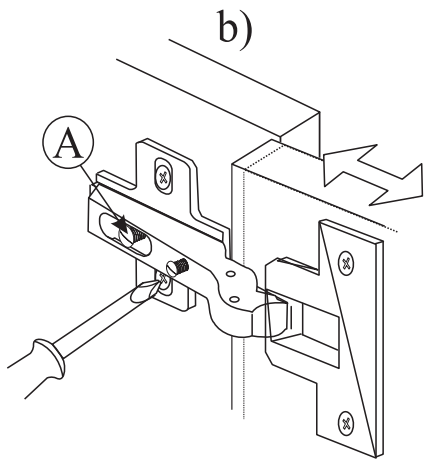
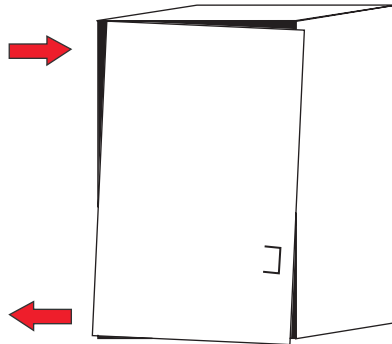
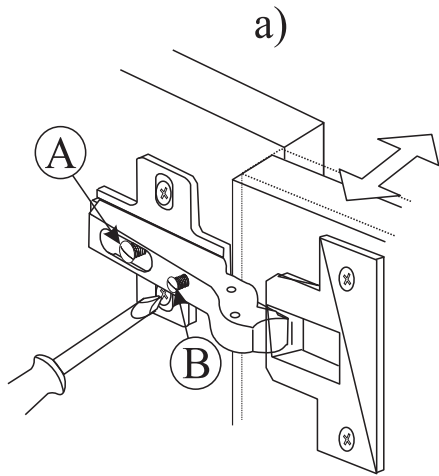

STEP 8

