

# ASSEMBLY INSTRUCTION

## DESCRIPTION: Type 317 BOOM

### 2.5 hrs

APPROXIMATE ASSEMBLY TIME  
EXCLUDING GLUE SETTING TIME

2 PERSON ASSEMBLY



FLOOR AREA  
2,5M X 2,5M

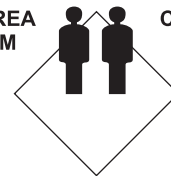

CEILING HEIGHT  
2,0M

REQUIRED ASSEMBLY SPACE

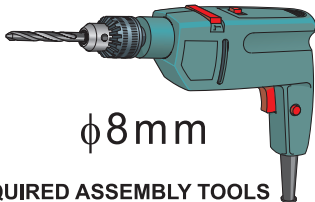

$\phi 8\text{mm}$

REQUIRED ASSEMBLY TOOLS

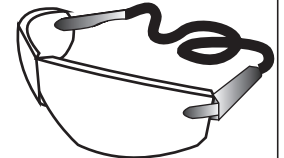
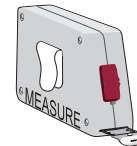

ASSEMBLED DIMENSIONS

### PACK 1

CONSISTS OF PARTS :  
**1, 2, 3, 4, 6, 8, 9, 11.**  
**Fittings**

### PACK 2

CONSISTS OF PARTS :  
**5, 7, 10, 13, 14, 15.**

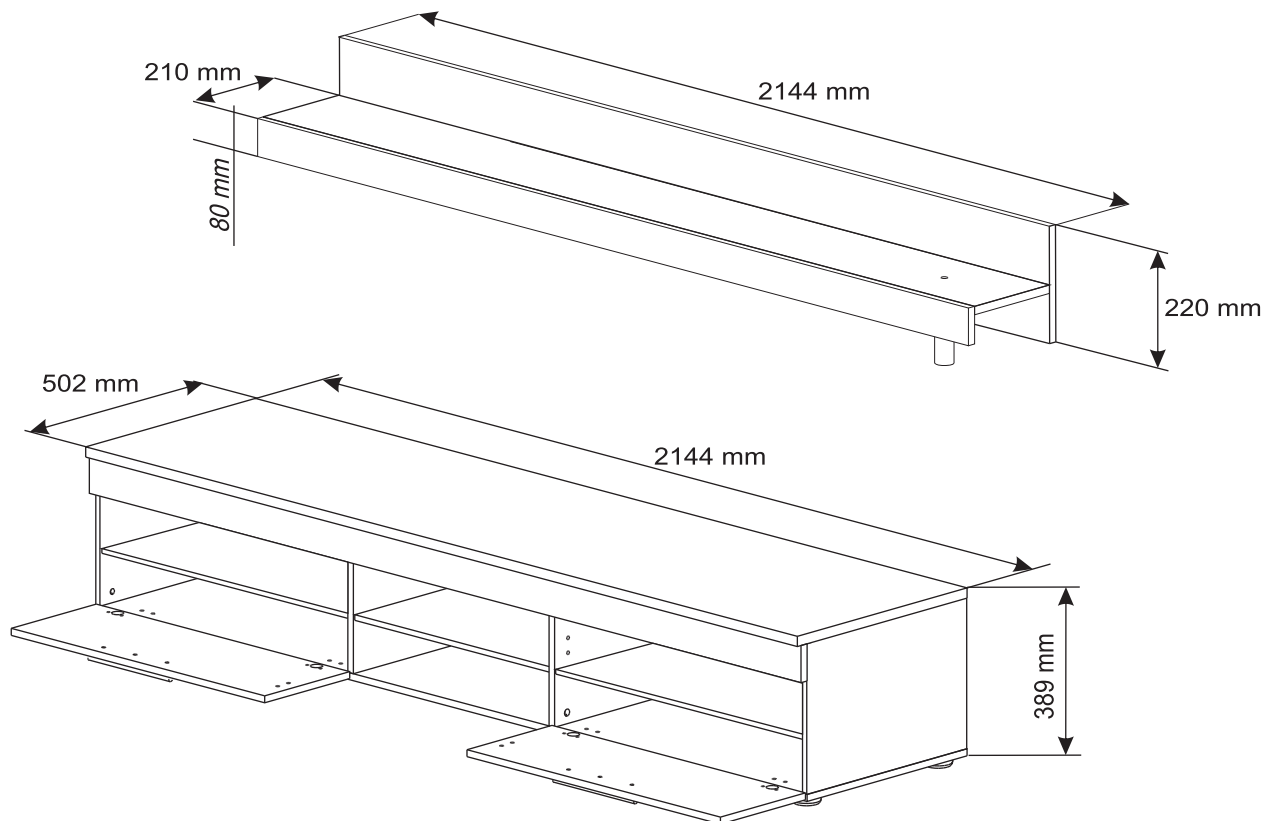

# PART LIST

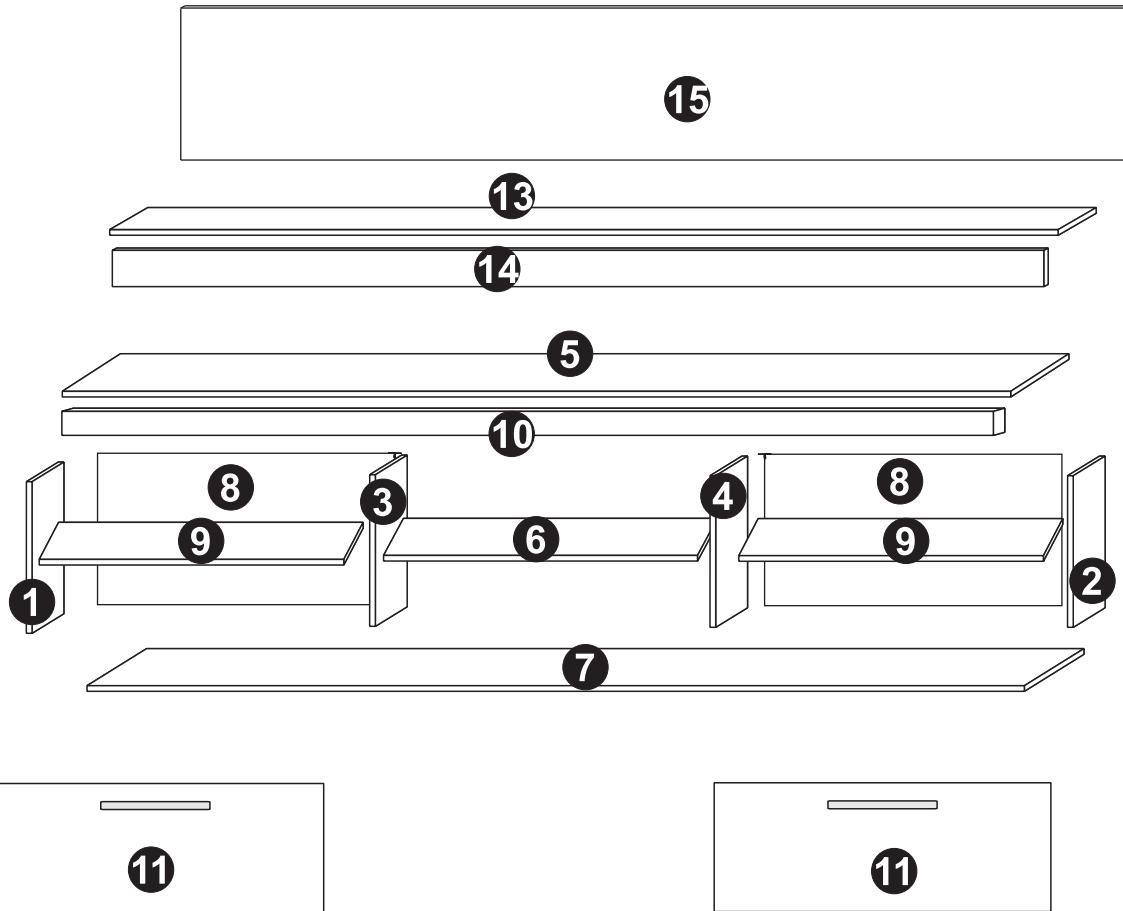

## NO. PARTS LIST

## QTY

## NO. PARTS LIST

## QTY

- (1) LEFT SIDE PANEL
- (2) RIGHT SIDE PANEL
- (3) LEFT DIVIDER
- (4) RIGHT DIVIDER
- (5) TOP PANEL
- (6) SHELF
- (7) BOTTOM PANEL
- (8) BACK PANEL
- (9) R/L SHELF
- (10) PLINTH
- (11) FLAP

- 1
- 1
- 1
- 1
- 1
- 1
- 1
- 2
- 2
- 1
- 2

- (13) HANGING SHELF
- (14) HANGING SHELF PLINTH
- (15) BACK PANEL

- 1
- 1
- 1
- 1



# HARDWARE LIST

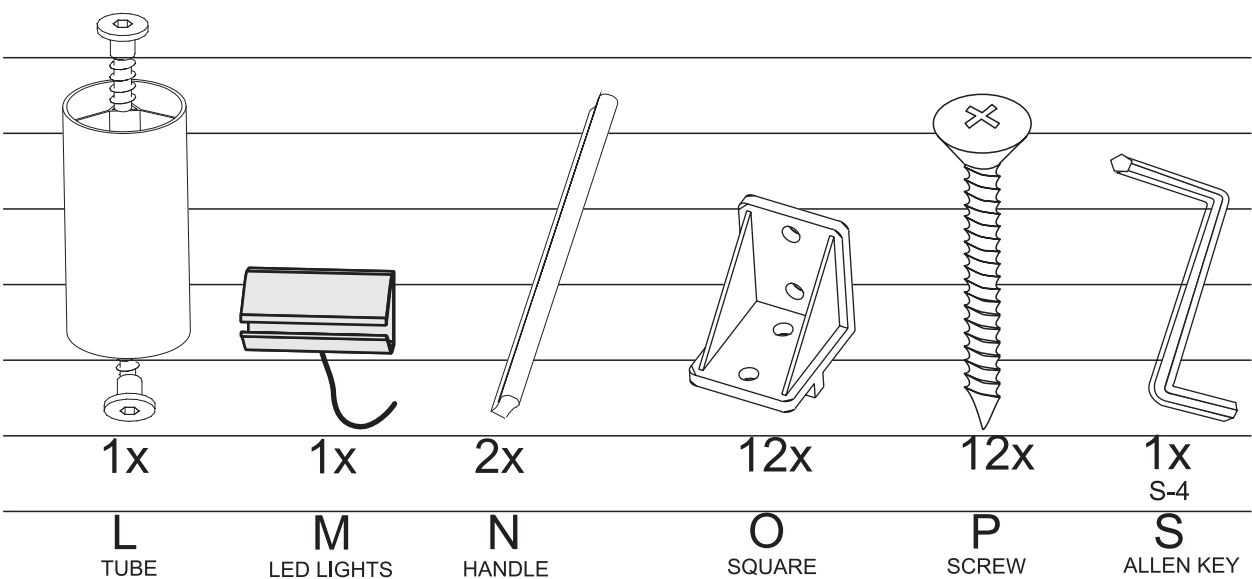
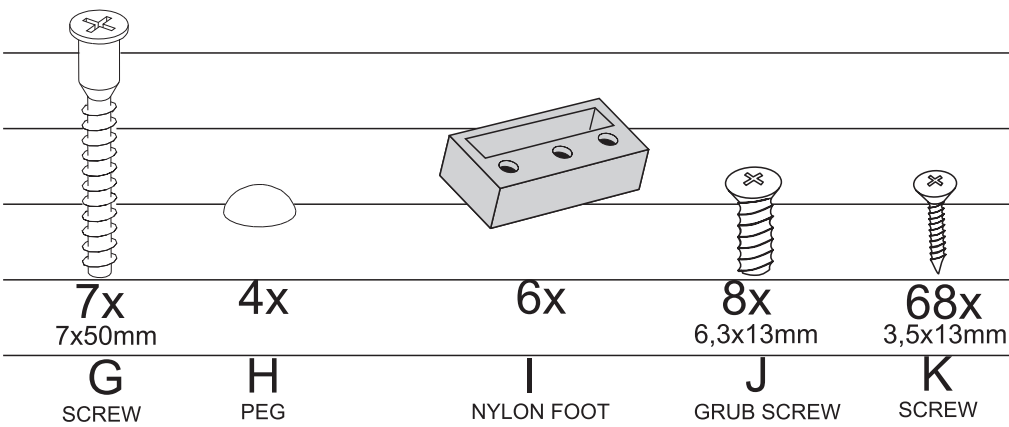
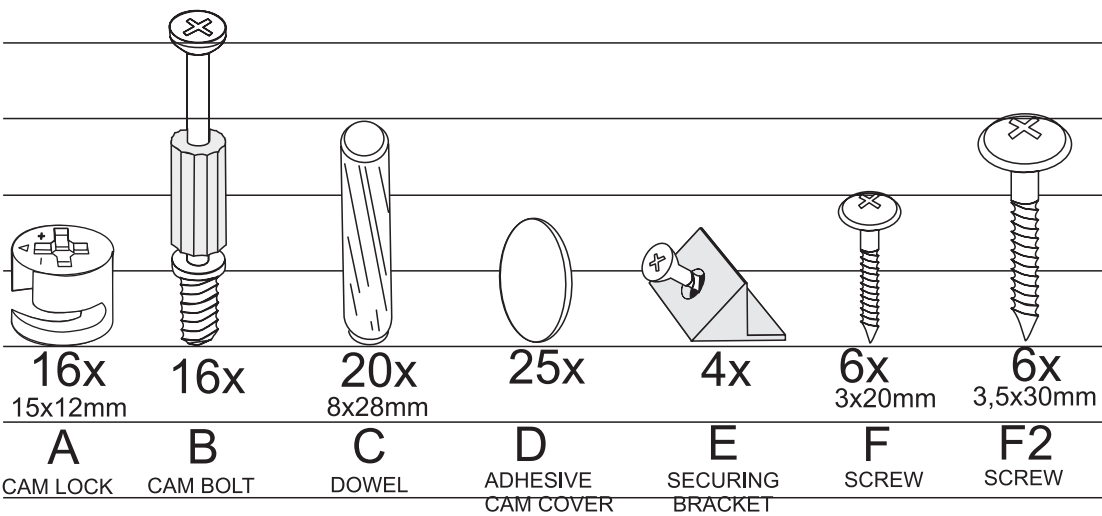

# HARDWARE LIST



2x  
R

CONCATENATION



2x  
S

FLAPS SETTING INDICATOR

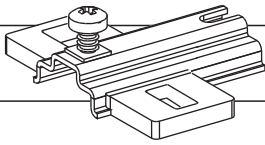

4x  
H-2  
V

HINGE PLATE

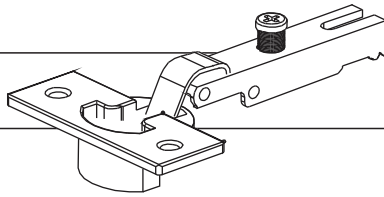

4x  
kr0  
W1

HINGE

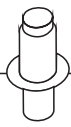

12x  
5x16mm

Z  
SHELF  
SUPPORT



2x

X  
LEVEL QUOIN

## **Top Tips before you start!**

1. Please check that all parts are present before you start the assembly of your furniture, as once assembled, the furniture is exempt from our home approval policy.
2. For ease and speed of assembly, we recommend that before you commence each step of the assembly, that you identify all the parts required for that step.
3. For larger items, please ensure that you have sufficient space and people ( as indicated on page 1) to assemble your product safely.
4. We recommend that, where possible, all items are assembled near to the area in which they will be placed in use, to avoid moving the product unnecessarily once assembled.
5. For the protection of your furniture, particularly items of high gloss finish, we recommend that the product is placed on a protected surface during assembly to prevent any damage.
6. During assembly please take care not to over-tighten any fittings, as this may damage the product .

## **Care and Maintenance of your Furniture**

Please periodically check all fittings and re-tighten as necessary.

Please do not sit or stand on this item.

Never allow any kind of liquid to remain on your furniture. Absorption can cause wood to warp or finishes to de-laminate.

Please do not drag and pull your furniture.

# SPECIAL TIPS FOR FITTING CAM-LOCKS AND CAM-PILLARS

## CAM-LOCK

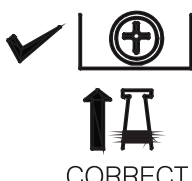
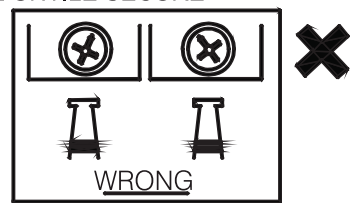

WHEN FITTING CAMS  
ENSURE STARTING POSITION IS CORRECT  
BEFORE YOU INSERT CONNECTING CAM-PILLAR  
TURN CLOCKWISE UNTIL SECURE

Align with long point of cross

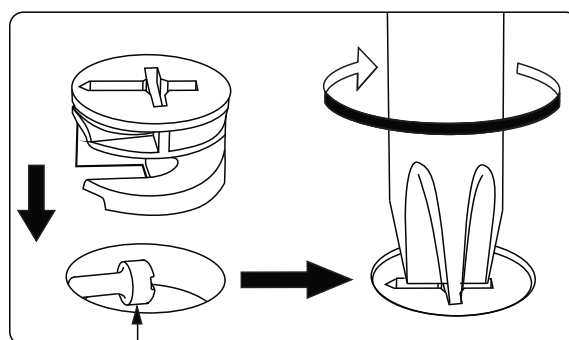

Pillar head needs to be in centre

## CAM-PILLAR

Tighten until shoulder is flush with panel. Do not overtighten or undertighten (see example below)

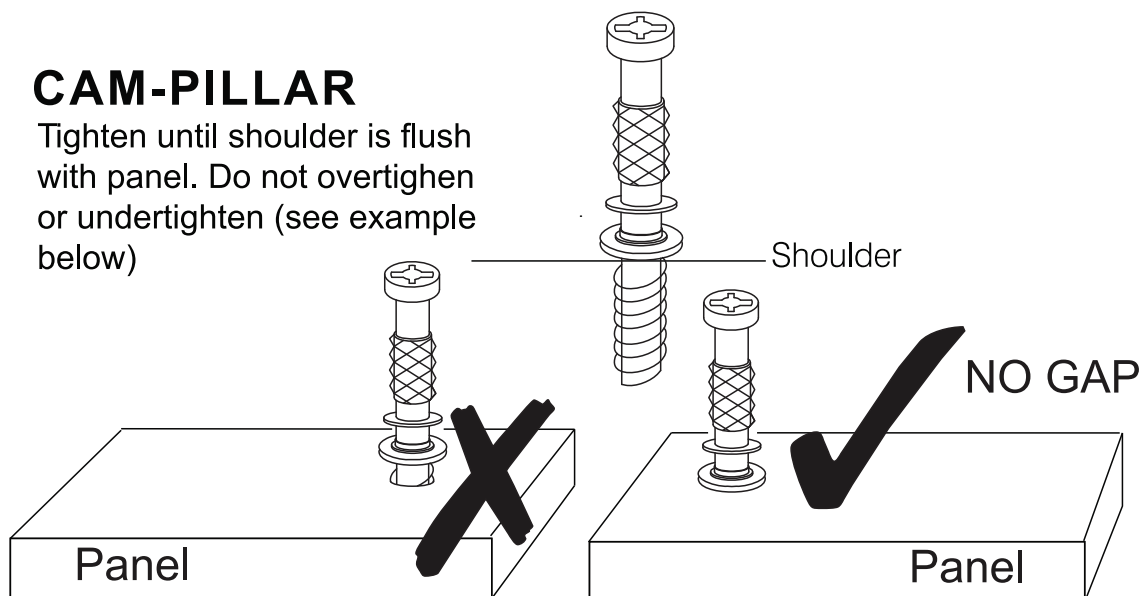

# STEP 1

12x 4x40mm P SCREW  
 6x I NYLON FOOT  
 16x B CAM BOLT  
 4x H-2 V HINGE PLATE  
 8x 6.3x13mm J GRUB SCREW

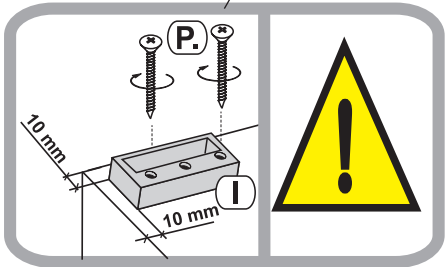
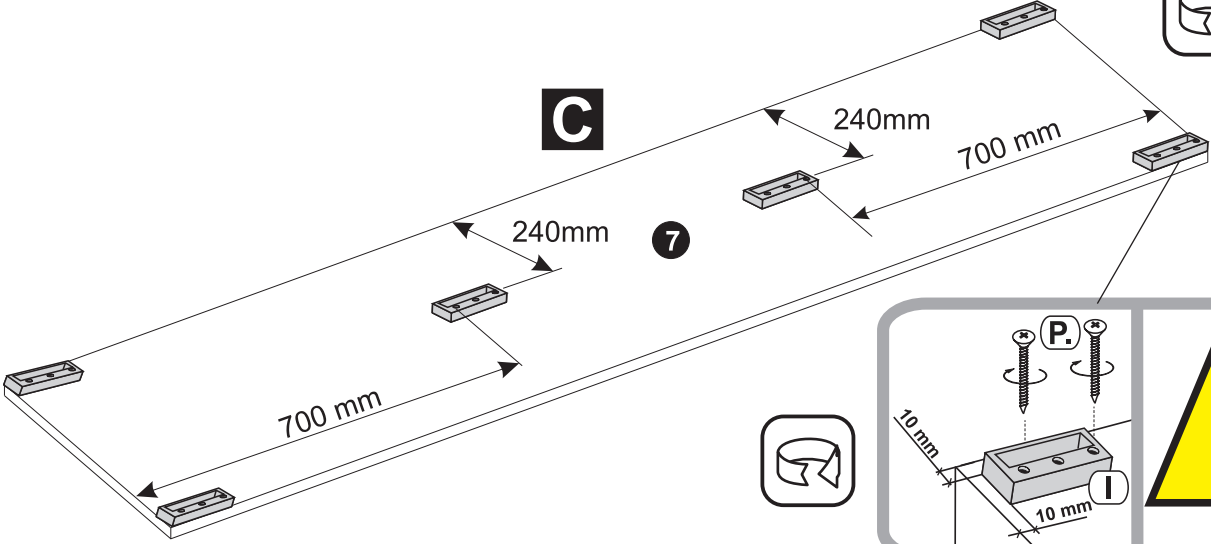
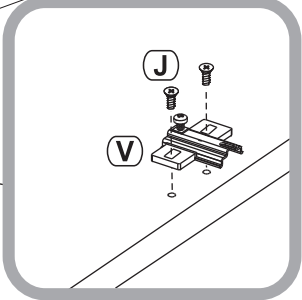
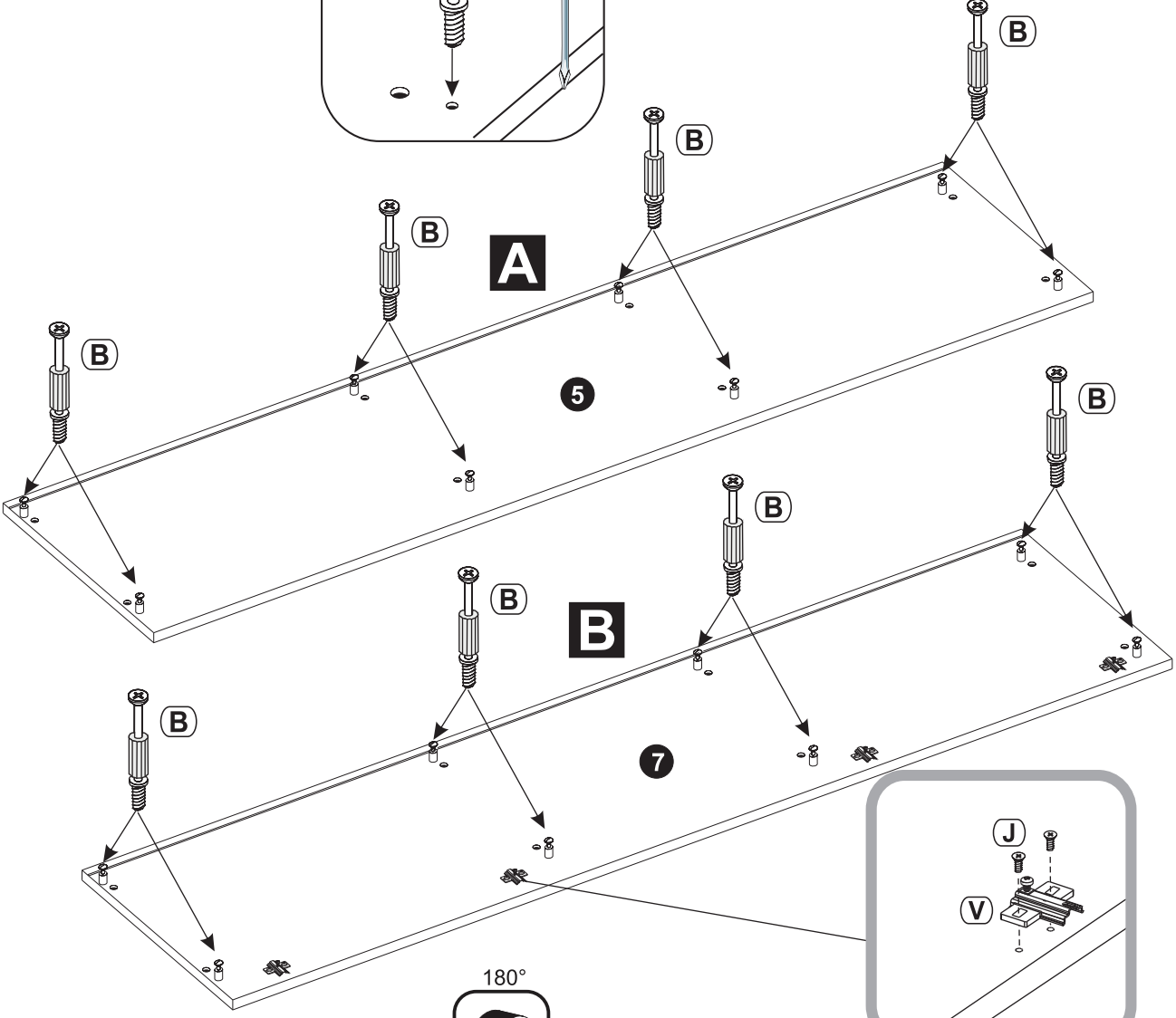
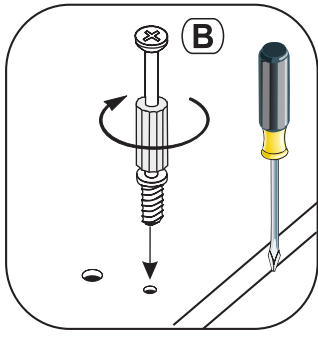

# STEP 2

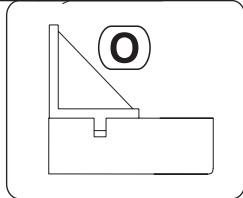
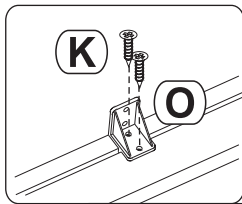

|        |          |
|--------|----------|
|        |          |
| 6x     | 12x      |
| SQUARE | 3,5x13mm |
|        | K        |
|        | SCREW    |

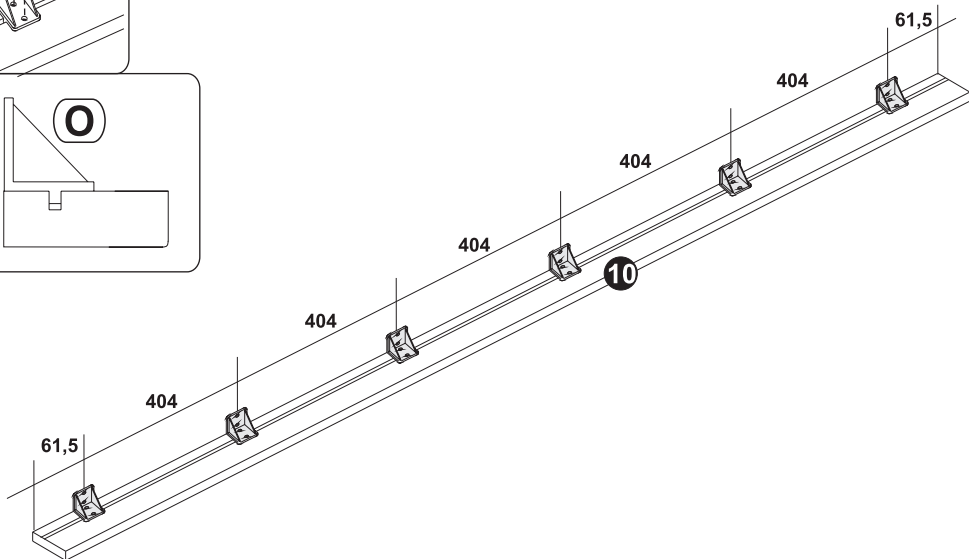

# STEP 3

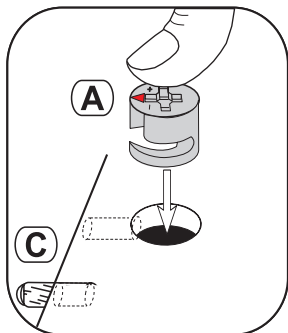

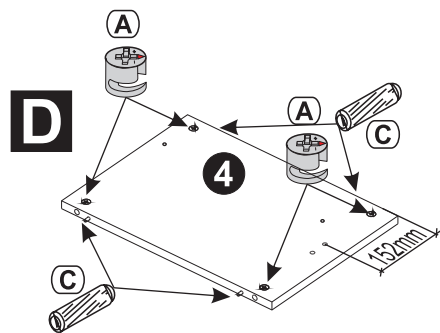
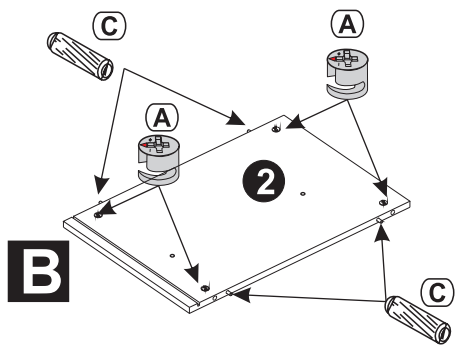
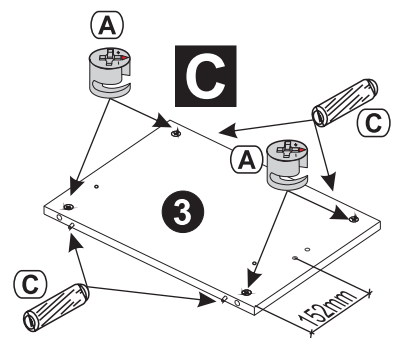
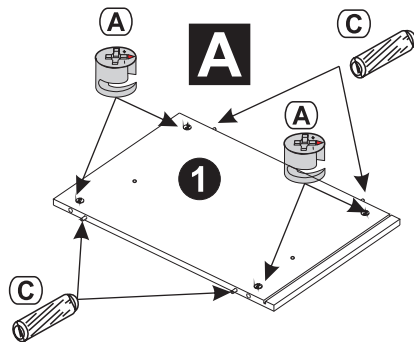

|          |        |
|----------|--------|
|          |        |
| 16x      | 16x    |
| 15x12mm  | 8x28mm |
| A        | C      |
| CAM LOCK | DOWEL  |



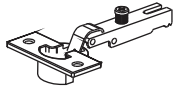

# STEP 4

|   |   |   |
|---|---|---|
|  |  |  |
| 2x  | 14x   | 1:2   |
| S   | 3,5x13mm  | 4x  |
| FLAPS SETTING INDICATOR   | K   | kr0   |
|   | SCREW   | W1  |
|   |   | HINGE   |

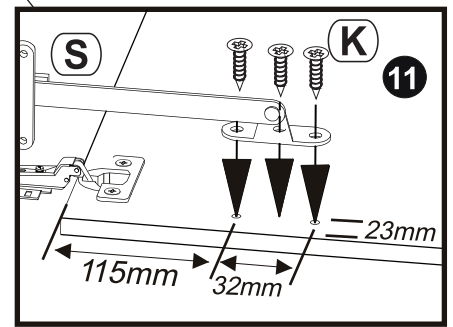
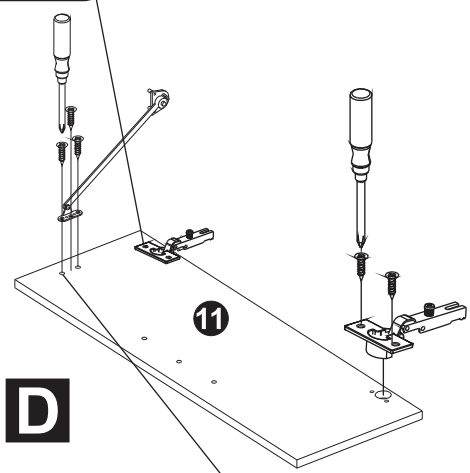
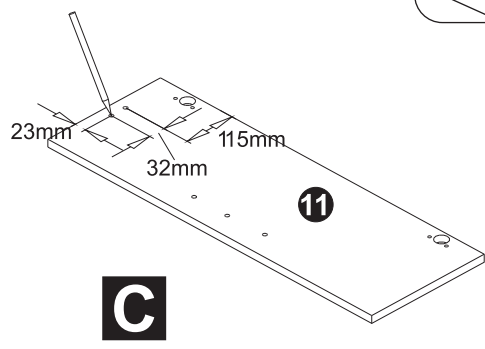
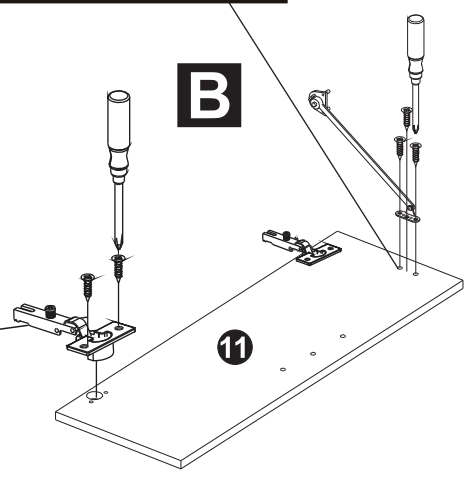
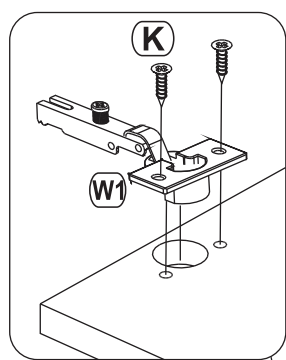
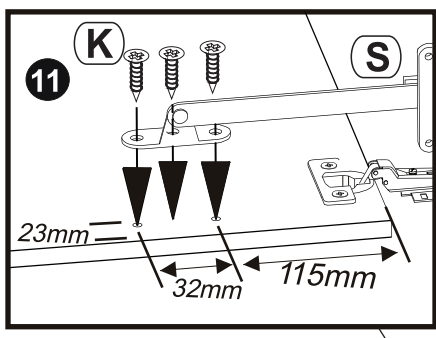
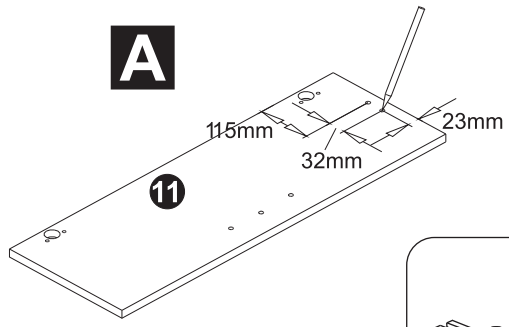

# STEP 5

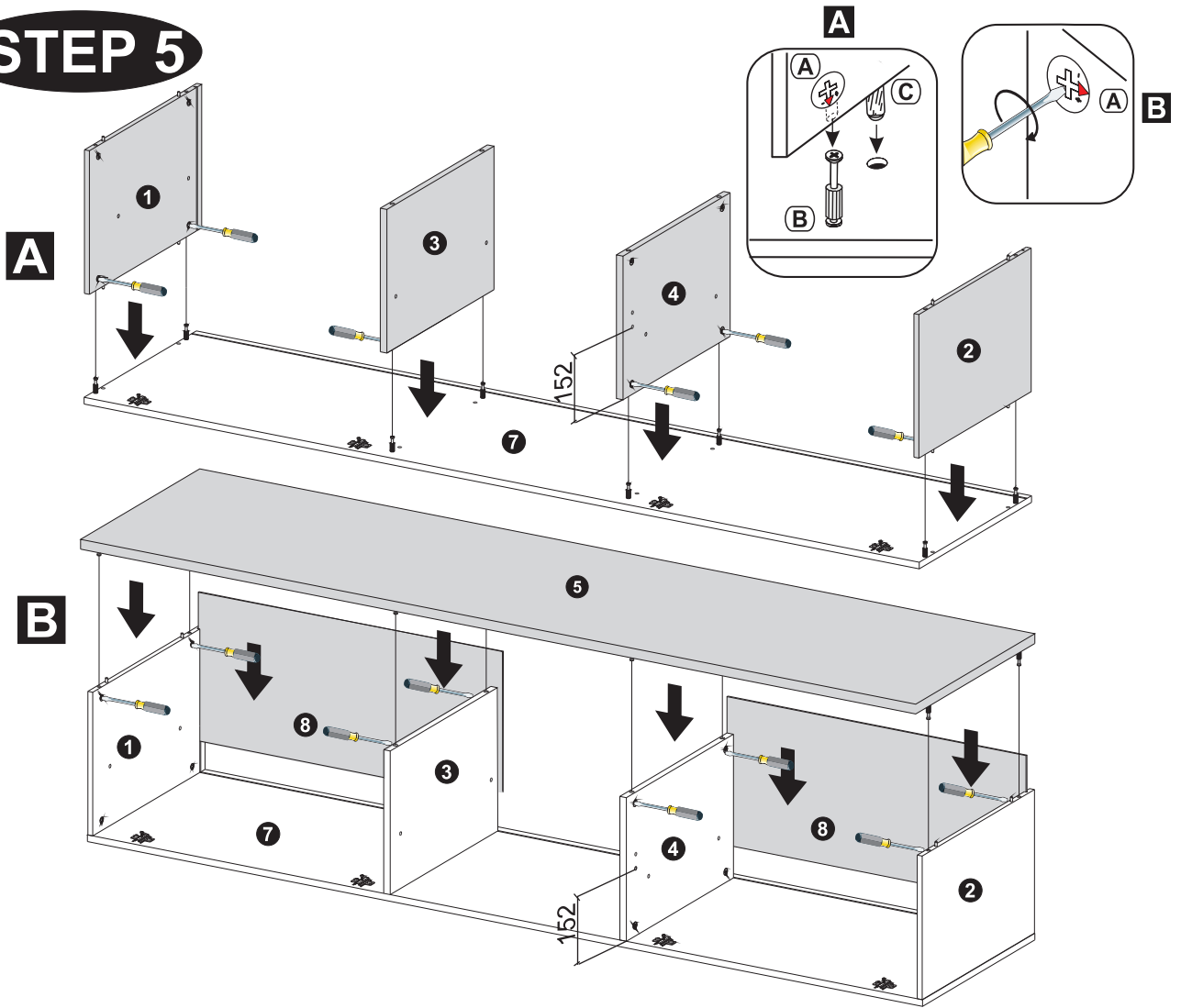

# STEP 6

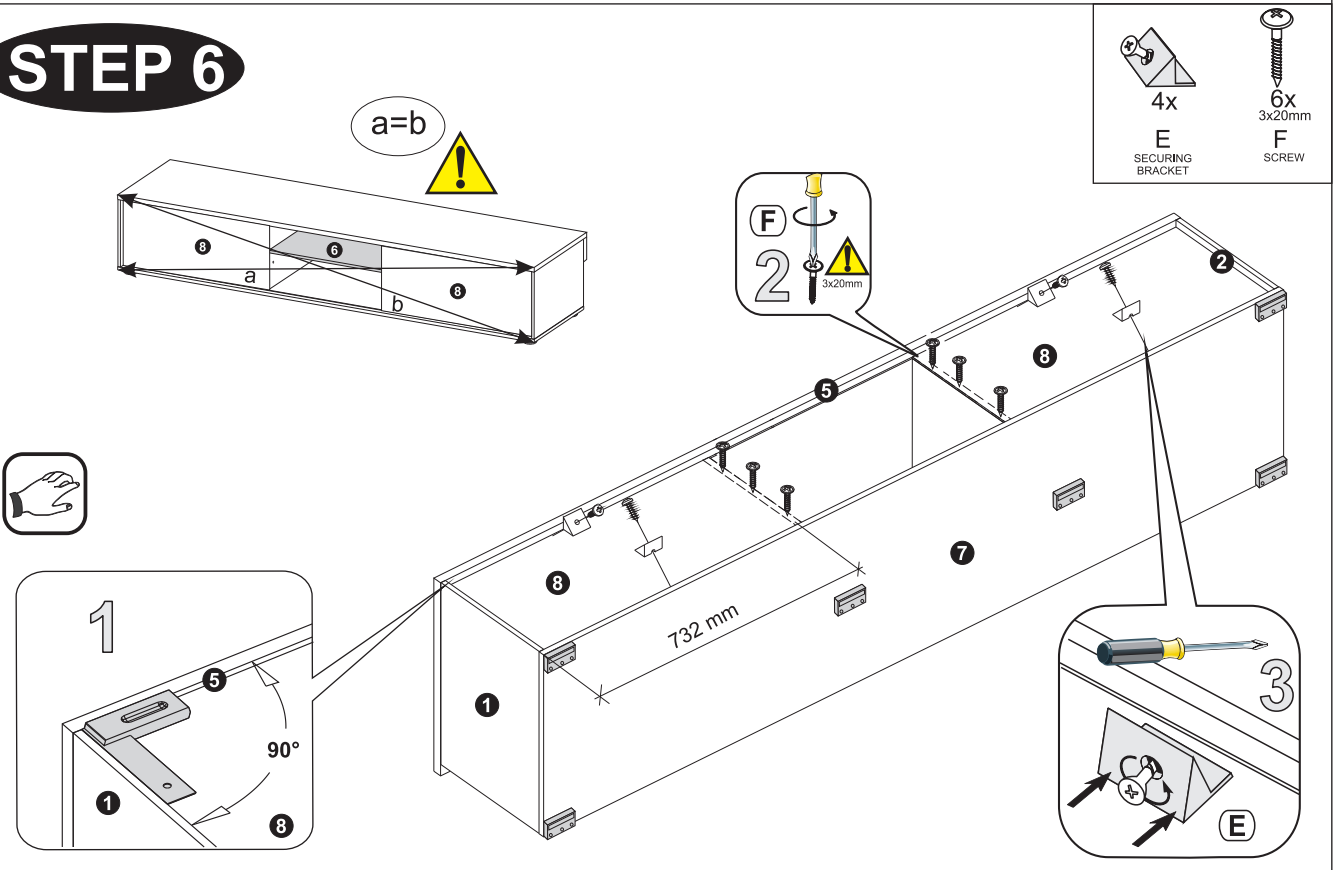

# STEP 7

12x  
3,5x13mm  
K  
SCREW

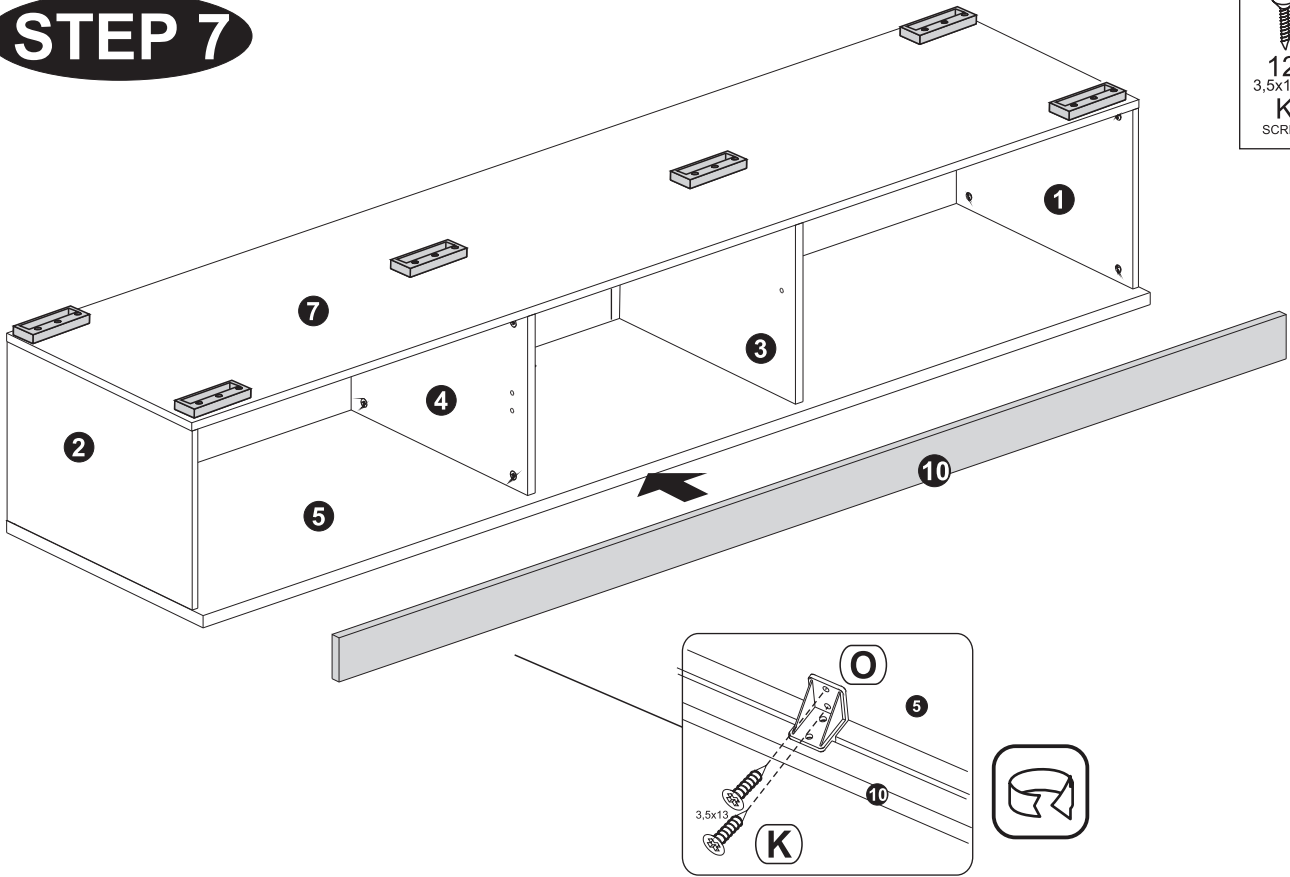

# STEP 8

4x  
5x16mm  
Z  
SHELF  
SUPPORT

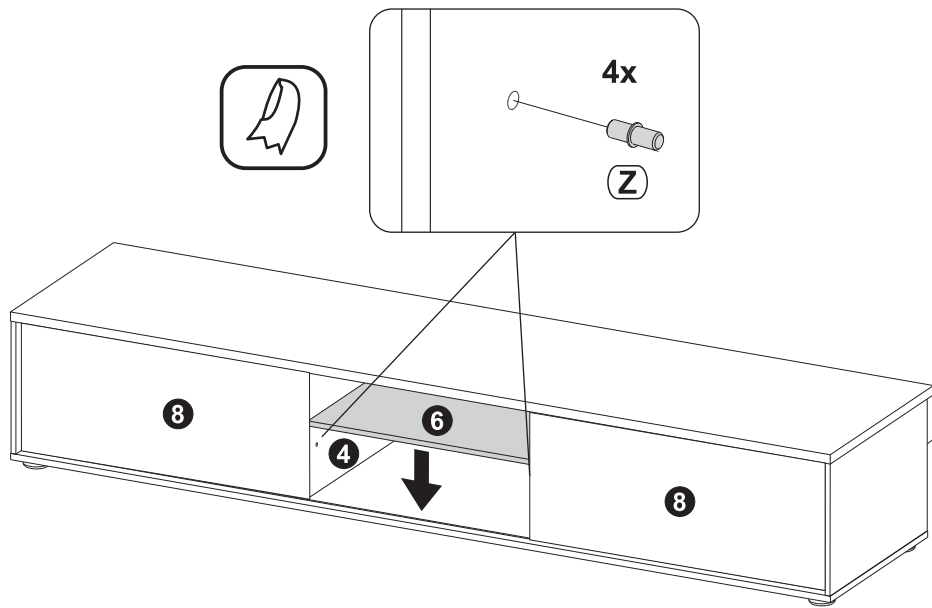

# STEP 9

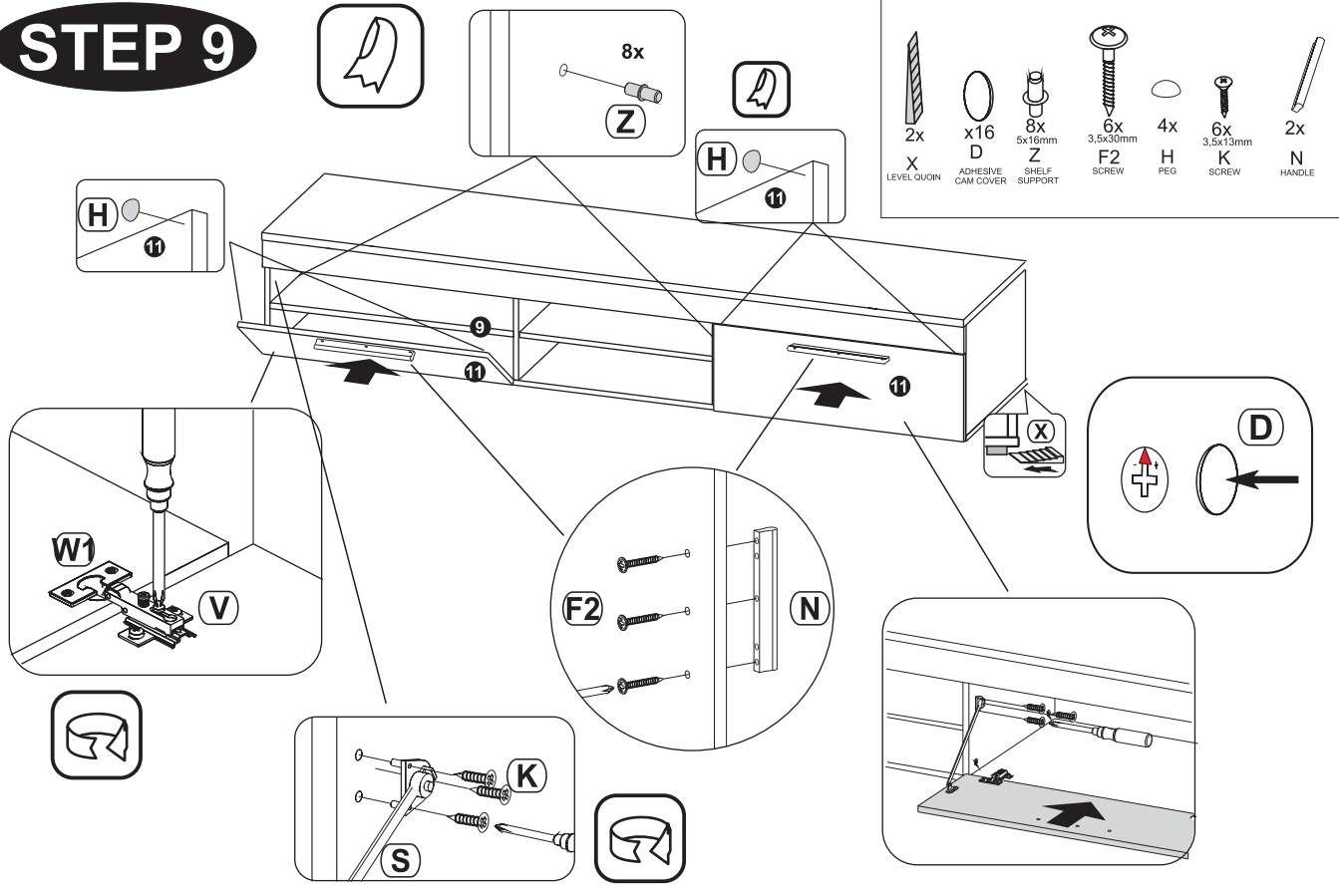

# STEP 10

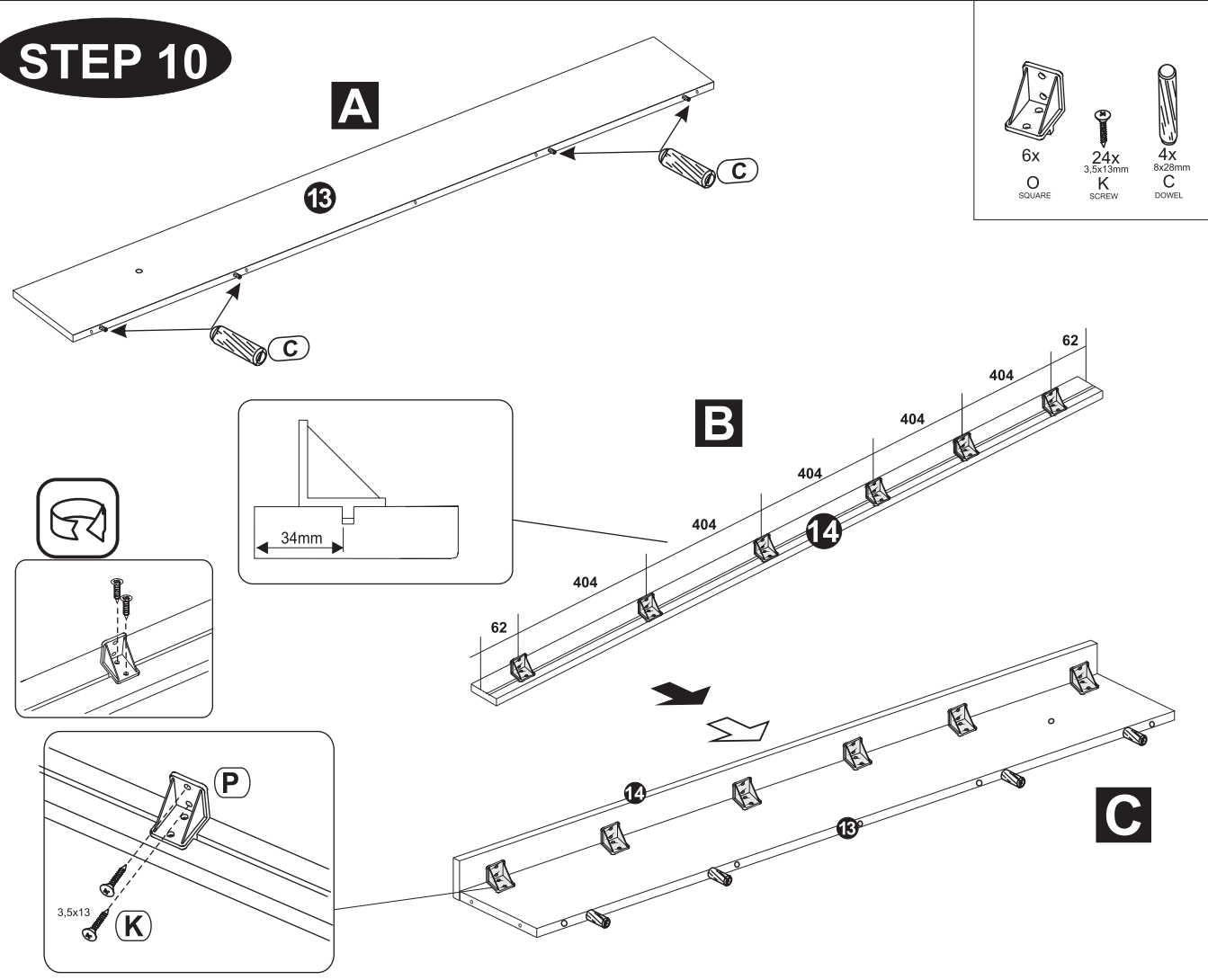

# STEP 11

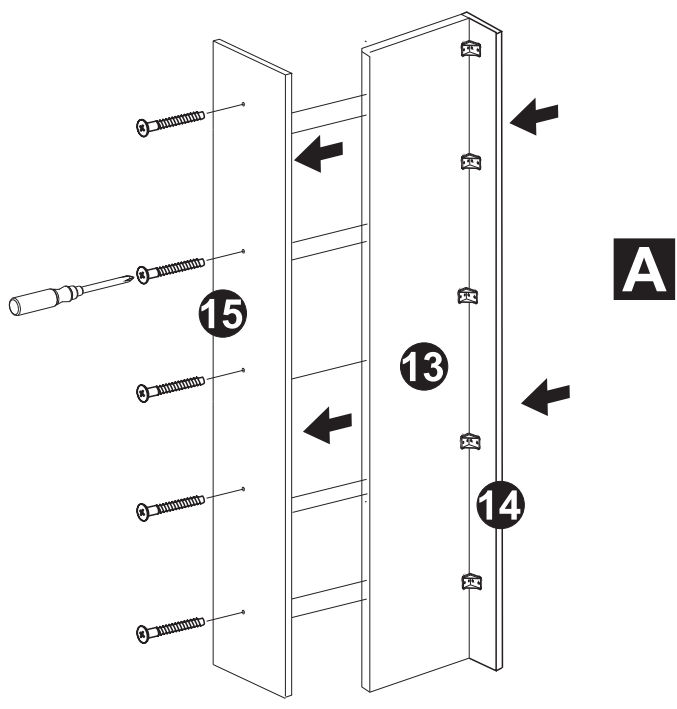
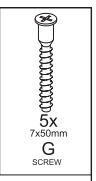

**B**

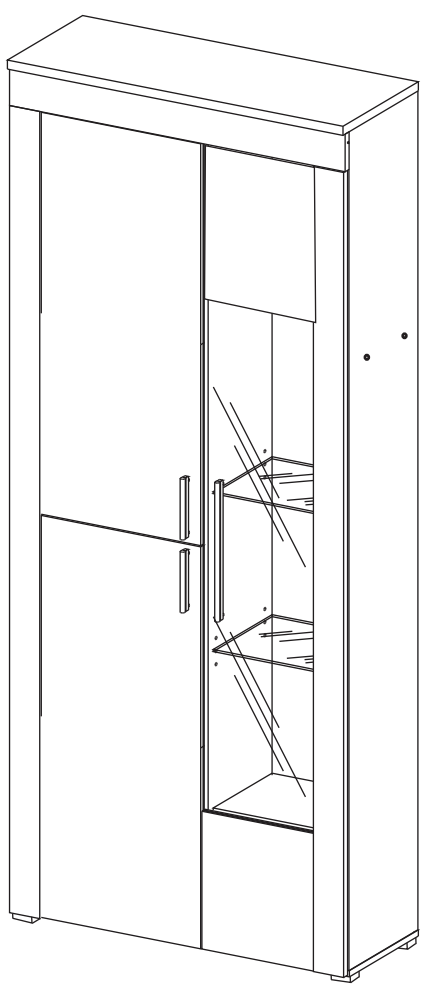

**C**

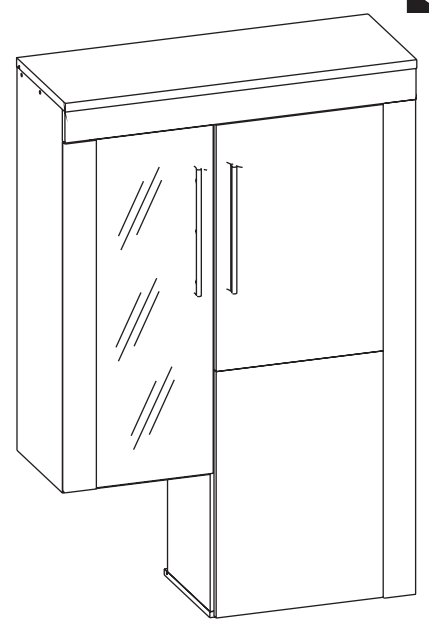

# STEP 12

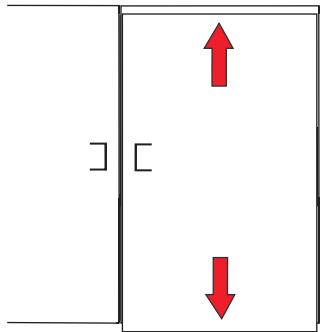
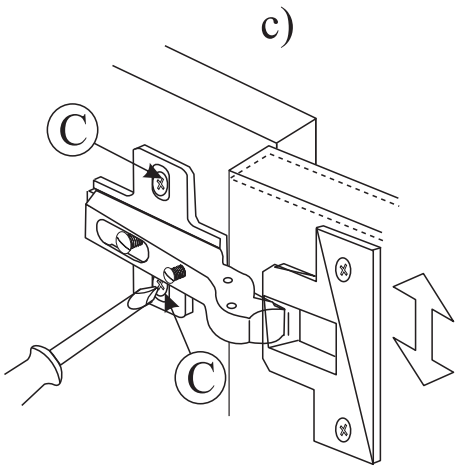
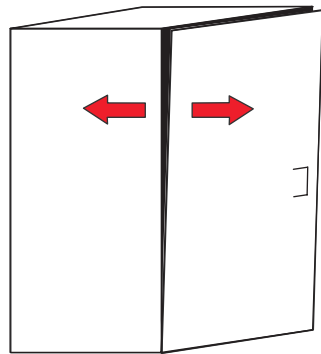
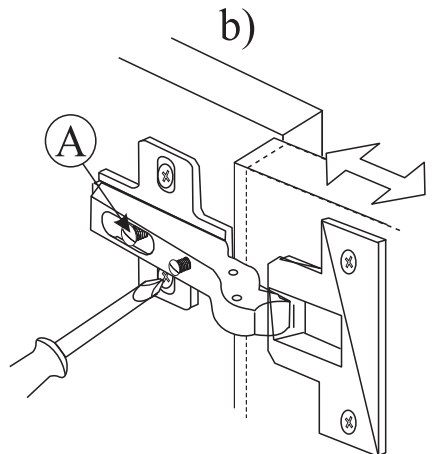
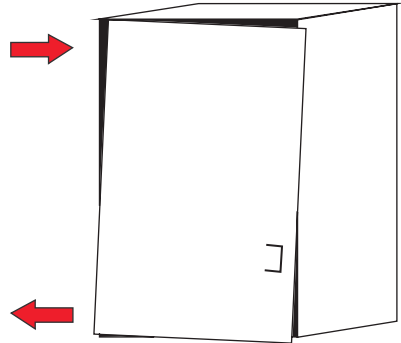
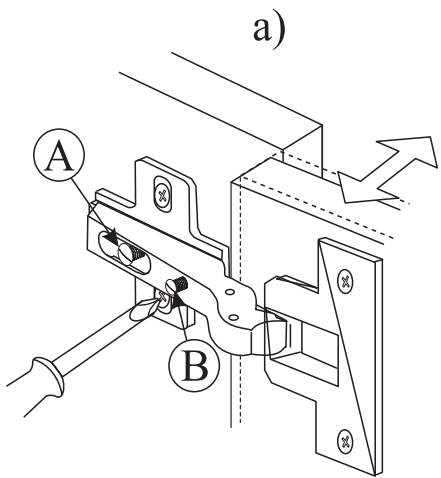



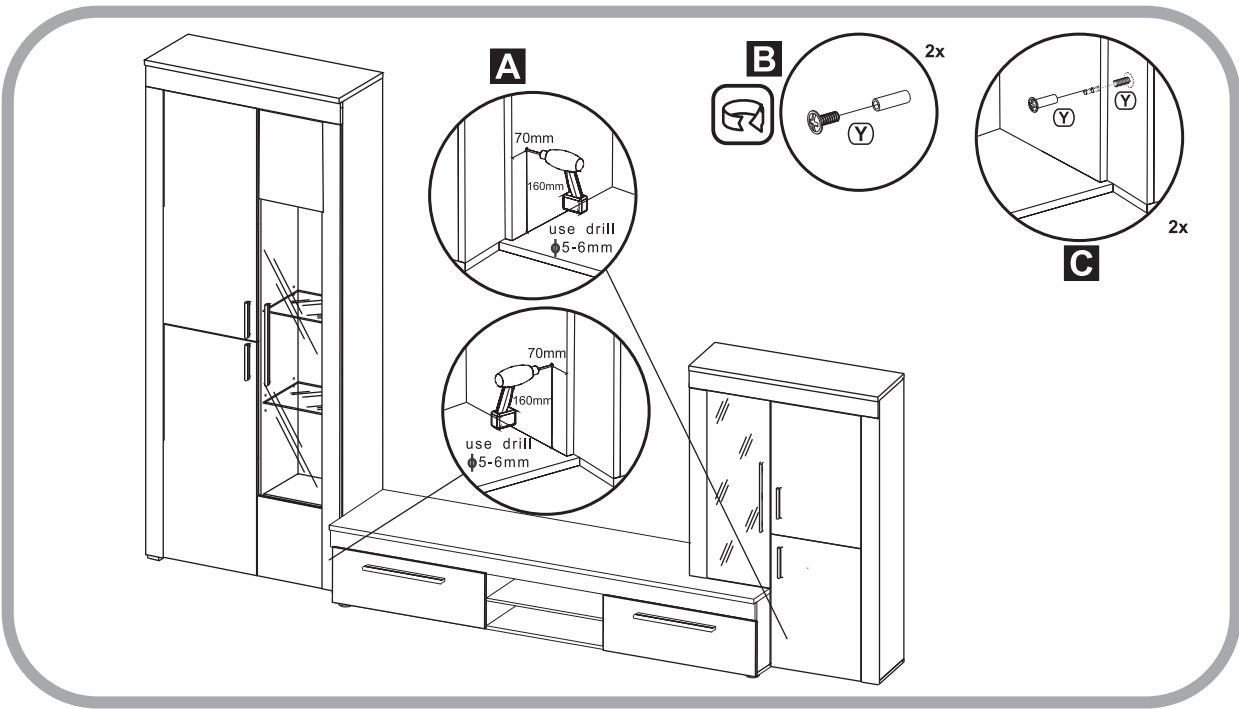
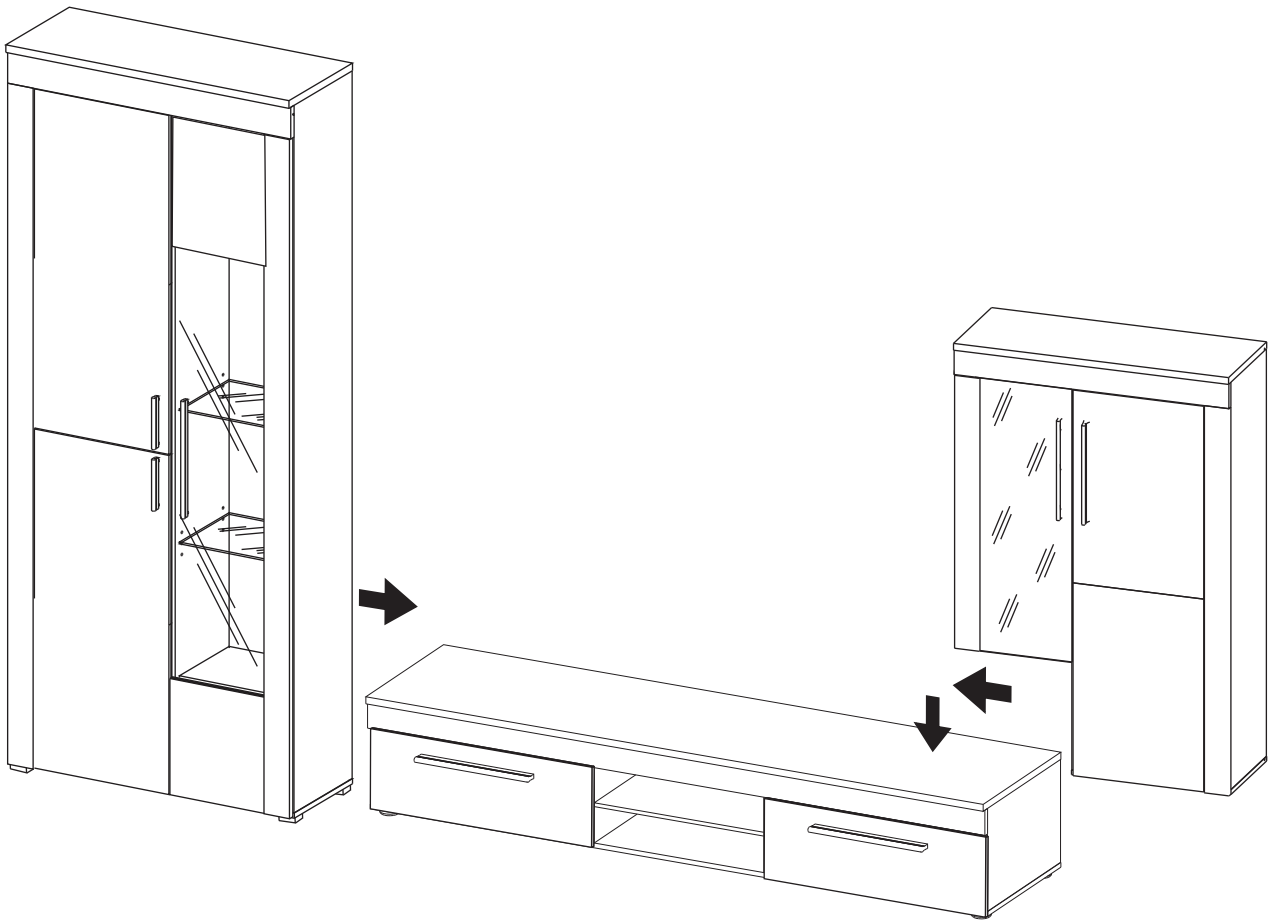

# STEP 13

2x  
Y  
CONCATENATION

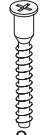

# STEP 14

-   
 1x  
**L**  
TUBE
-   
 1x  
**S**  
ALLEN KEY
-   
 1x  
**Q**  
LED LIGHTS
-   
 9x  
**D**  
ADHESIVE  
CAM COVER
-   
 2x  
**G**  
7x50mm  
SCREW



**1**  "use drill Ø8mm"

**2**   $\phi 8$

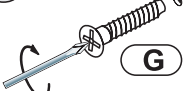
**3**  **G**

**4**  **D**

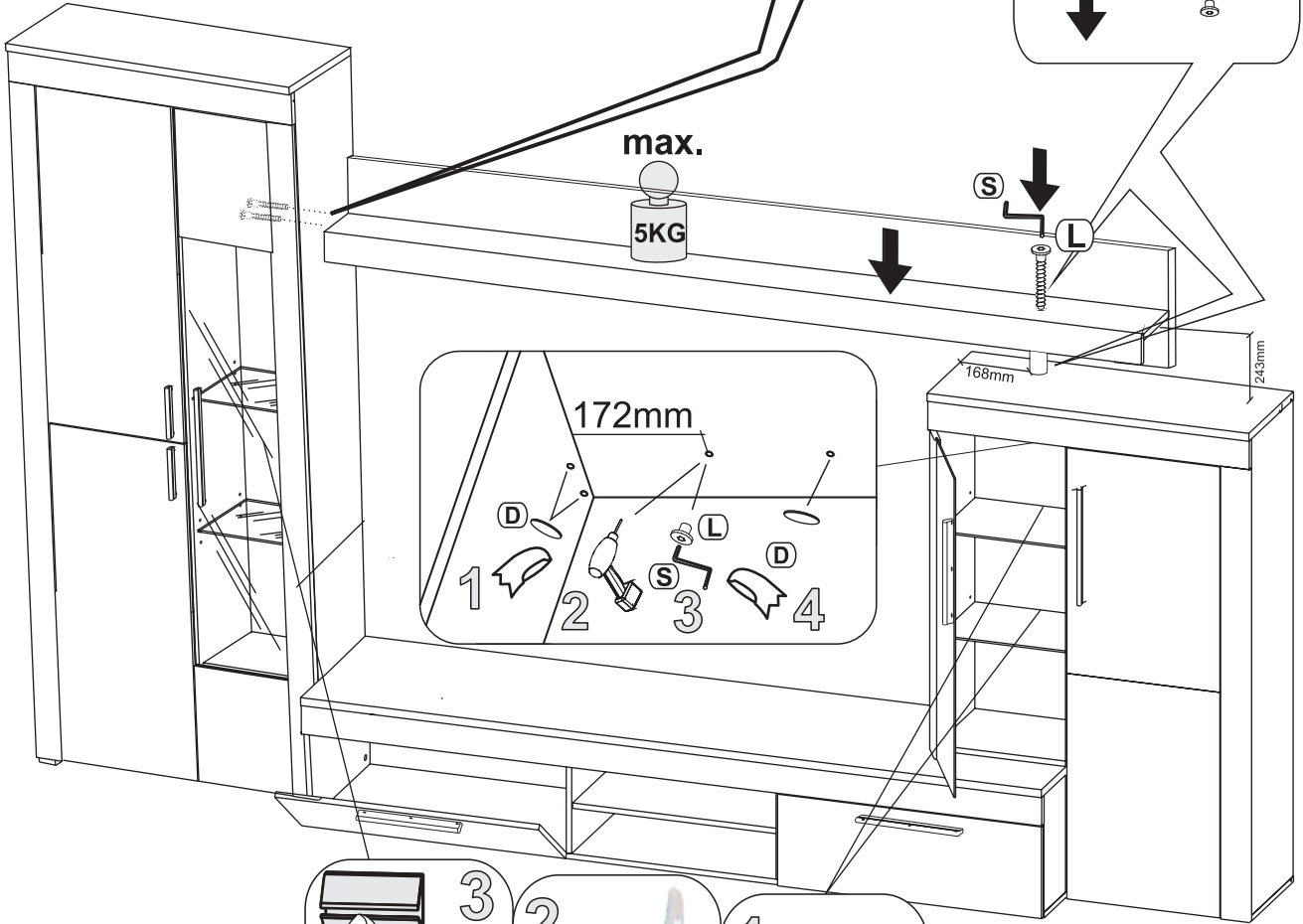
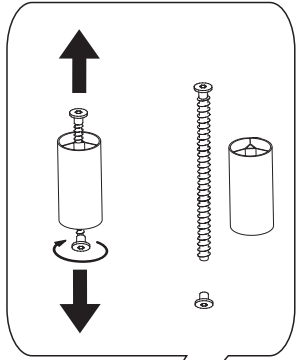

**Option LED**

**3**

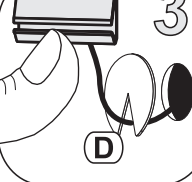

**D**

**2**



**1**

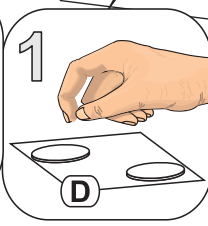

**D**