

# ASSEMBLY INSTRUCTION

## DESCRIPTION: Type 037 BOOM

### 2.5 hrs

APPROXIMATE ASSEMBLY TIME  
EXCLUDING GLUE SETTING TIME

2 PERSON ASSEMBLY



FLOOR AREA  
2,5M X 2,5M

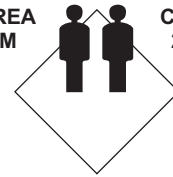

CEILING HEIGHT  
2,0M

REQUIRED ASSEMBLY SPACE

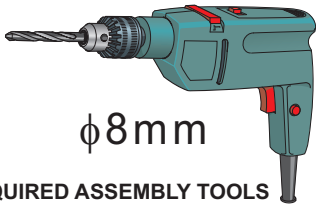

$\phi 8\text{mm}$

REQUIRED ASSEMBLY TOOLS

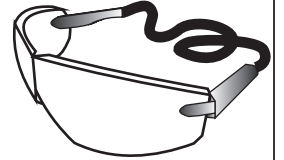
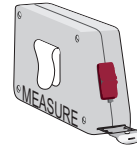
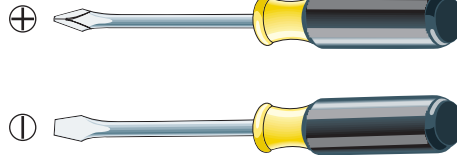

ASSEMBLED DIMENSIONS

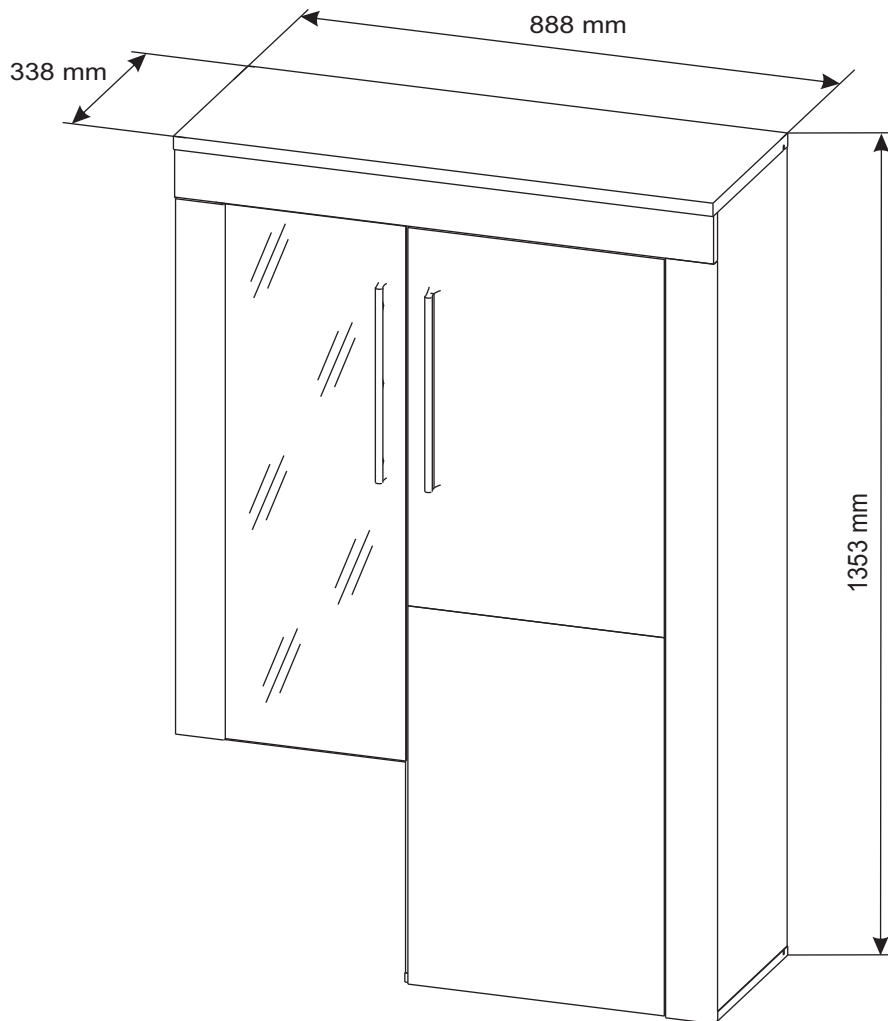

# PART LIST

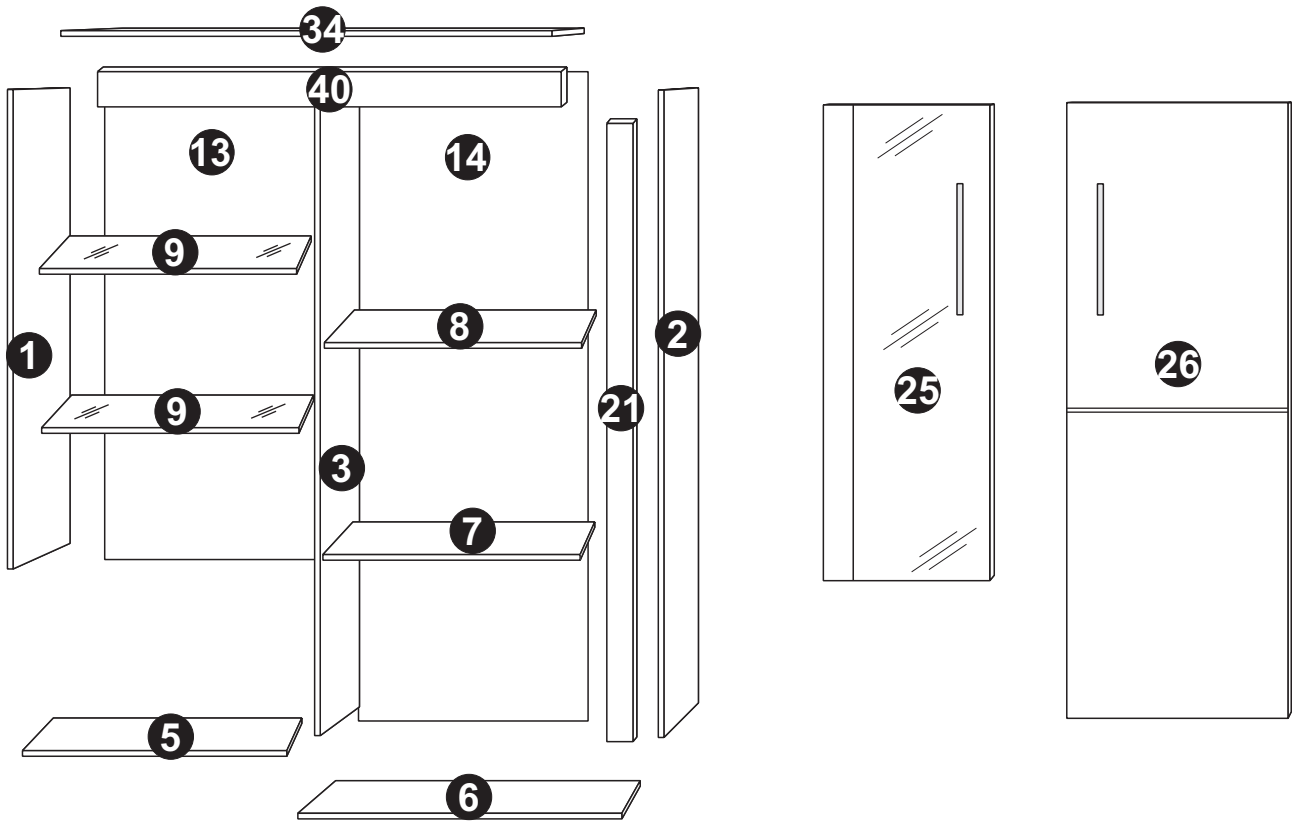

NO. PARTS LIST	QTY	NO. PARTS LIST	QTY
(1) LEFT SIDE PANEL	1	(25) LEFT DOOR W/GLASS	1
(2) RIGHT SIDE PANEL	1	(26) RIGHT DOOR	1
(3) CENTER DIVIDER	1	(40) PLINTH	1
(34) TOP PANEL	1		
(5) HORIZONTAL DIVIDER	1		
(6) BOTTOM PANEL	1		
(7) RIGHT HORIZONTAL DIVIDER	1		
(8) SHELF	1		
(9) SHELF GLASS	2		
(13) LEFT BACK PANEL	1		
(14) RIGHT BACK PANEL	1		
(21) RIGHT PLINTH			



# HARDWARE LIST

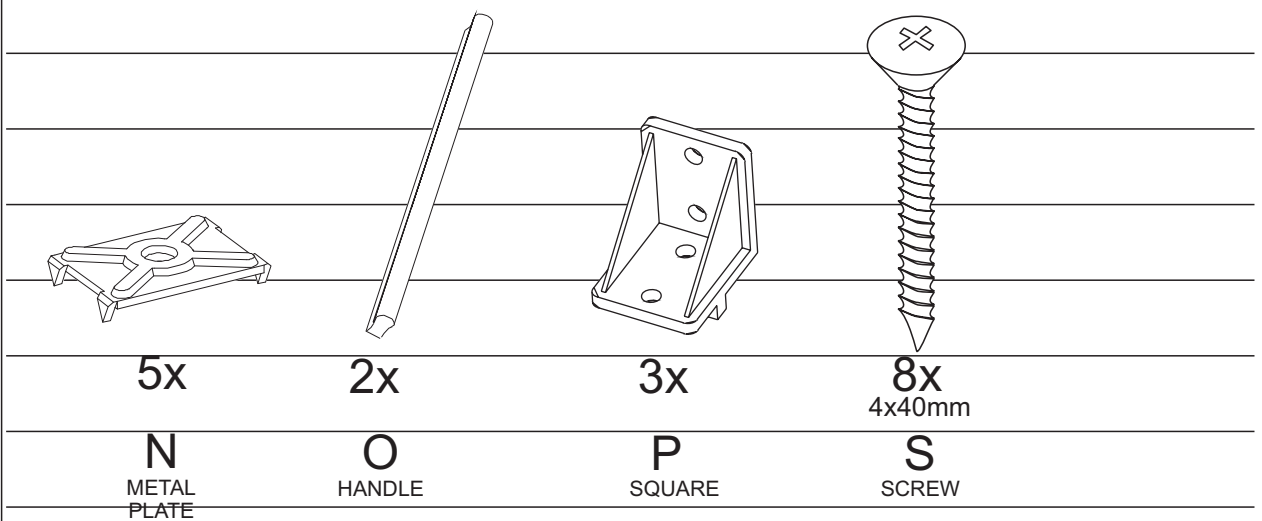
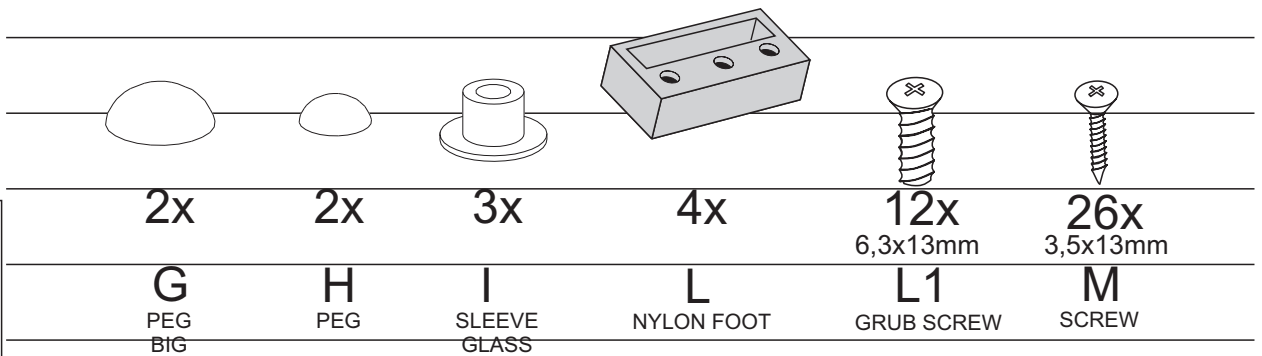
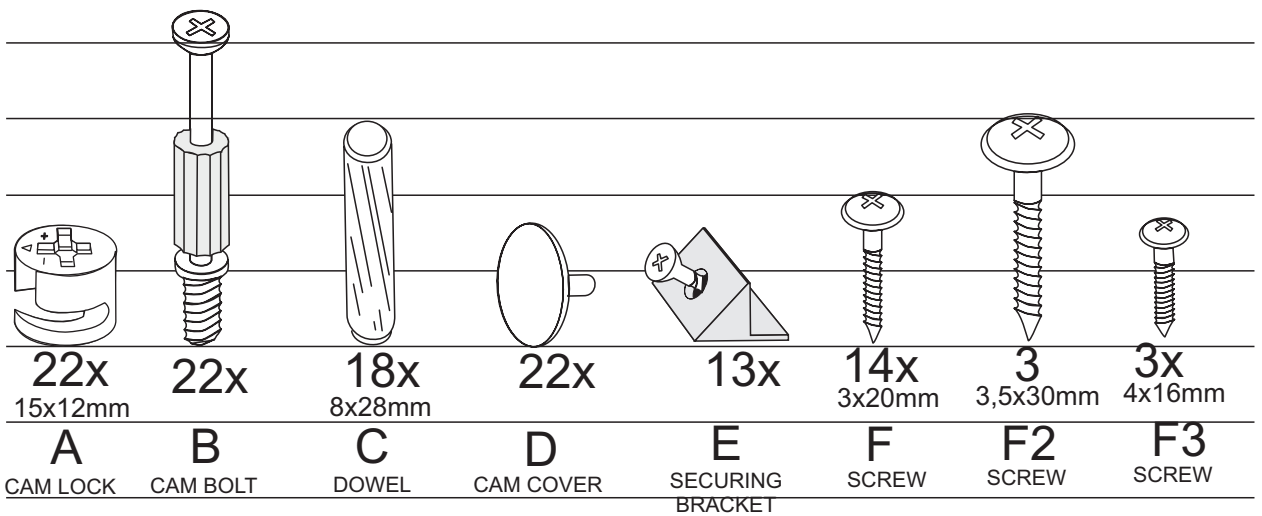

# HARDWARE LIST

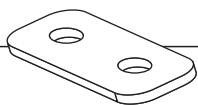

1x

**Q**  
METAL  
PLATE

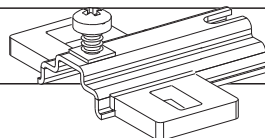
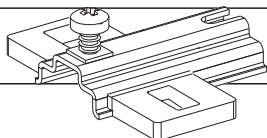

4x  
H-2

**V**

HINGE PLATE

2x  
H-2

**V**

HINGE PLATE

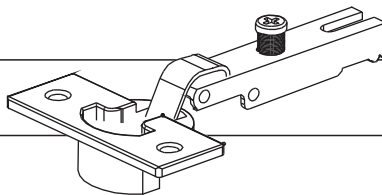
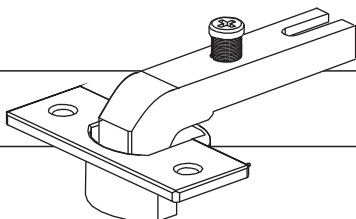

4x  
90°

**W**

HINGE

2x  
kr0

**W1**

HINGE

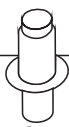

4x  
5x16mm

**Z**

SHELF  
SUPPORT



8x  
5x16mm

**Z1**

SHELF GLASS  
SUPPORT

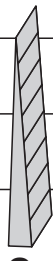

2x

**X**

LEVEL QUOIN

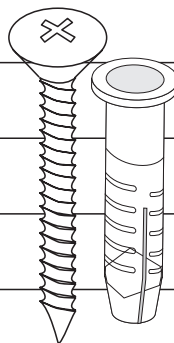

1x  
4x35mm

**R**

PLASTIC  
DOWEL

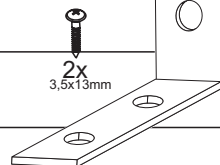

2x  
3.5x13mm

1x

**T**

ANGLE



## **Top Tips before you start!**

1. Please check that all parts are present before you start the assembly of your furniture, as once assembled, the furniture is exempt from our home approval policy.
2. For ease and speed of assembly, we recommend that before you commence each step of the assembly, that you identify all the parts required for that step.
3. For larger items, please ensure that you have sufficient space and people ( as indicated on page 1) to assemble your product safely.
4. We recommend that, where possible, all items are assembled near to the area in which they will be placed in use, to avoid moving the product unnecessarily once assembled.
5. For the protection of your furniture, particularly items of high gloss finish, we recommend that the product is placed on a protected surface during assembly to prevent any damage.
6. During assembly please take care not to over-tighten any fittings, as this may damage the product .

## **Care and Maintenance of your Furniture**

Please periodically check all fittings and re-tighten as necessary.

Please do not sit or stand on this item.

Never allow any kind of liquid to remain on your furniture. Absorption can cause wood to warp or finishes to de-laminate.



Please do not drag and pull your furniture.

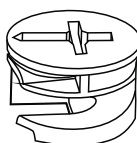

# SPECIAL TIPS FOR FITTING CAM-LOCKS AND CAM-PILLARS

## CAM-LOCK



WHEN FITTING CAMS  
ENSURE STARTING POSITION IS CORRECT  
BEFORE YOU INSERT CONNECTING CAM-PILLAR  
TURN CLOCKWISE UNTIL SECURE

✓   ✗

CORRECT WRONG

Align with long point of cross

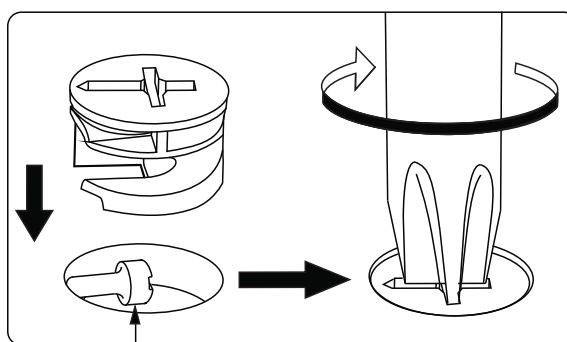

Pillar head needs to be in centre





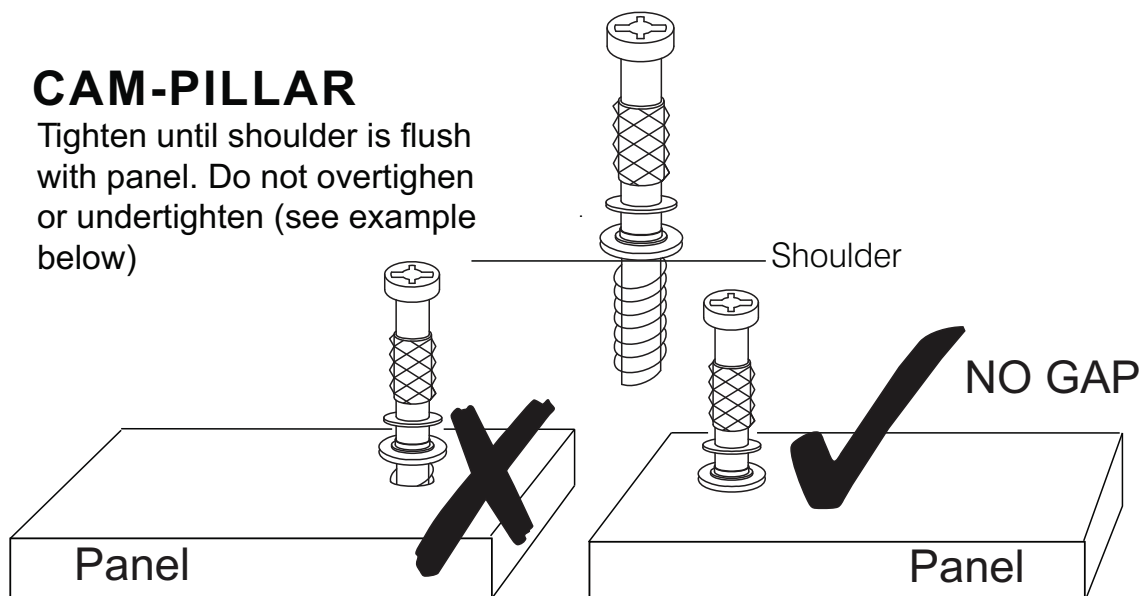

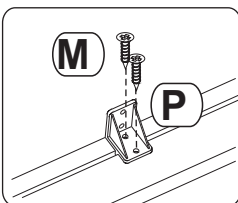

## CAM-PILLAR

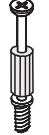
Tighten until shoulder is flush with panel. Do not overtighten or undertighten (see example below)









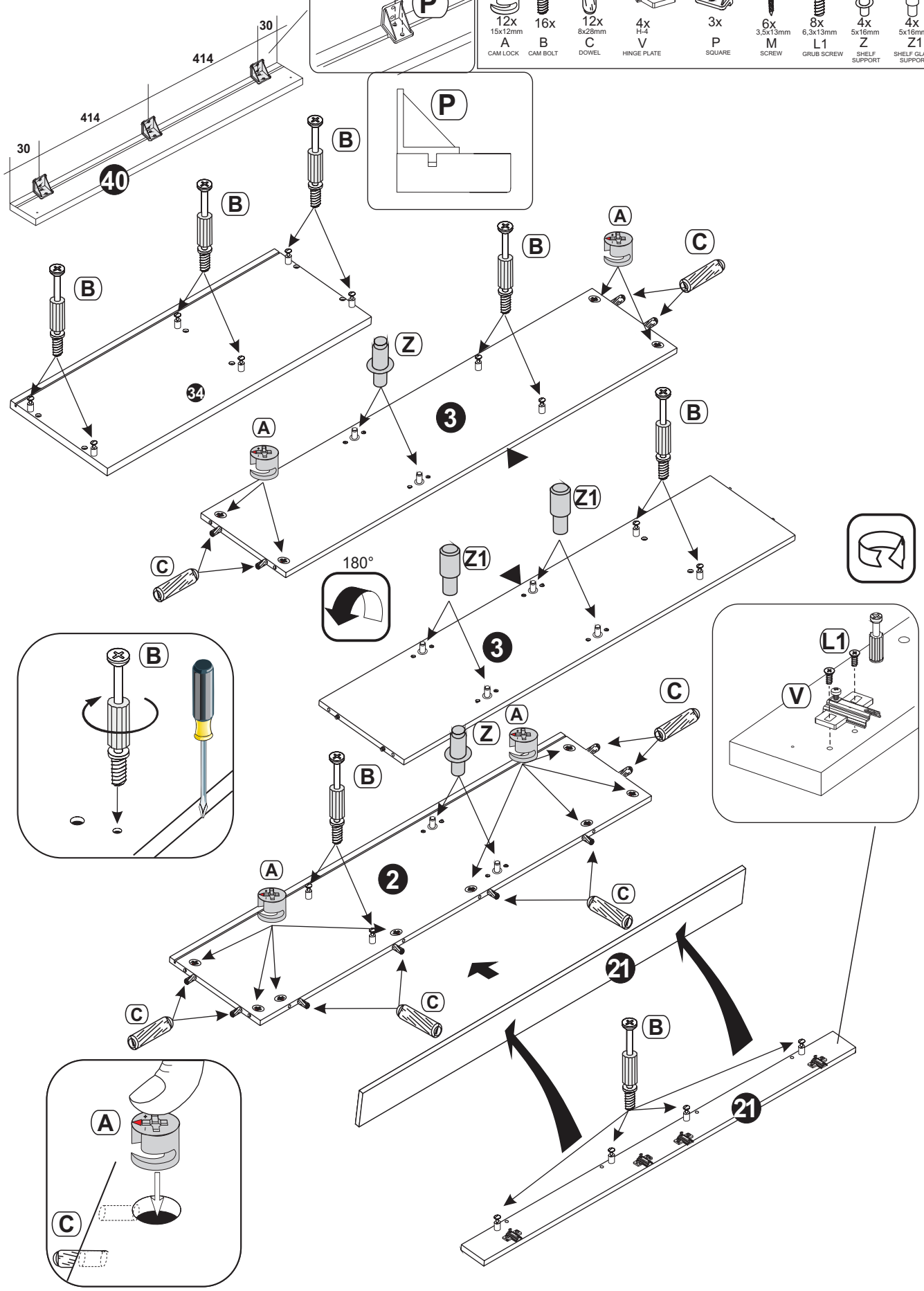

# STEP 1



-  12x 15x12mm  
A CAM LOCK
-  16x  
B CAM BOLT
-  12x 8x28mm  
C DOWEL
-  4x H-4  
V HINGE PLATE
-  3x  
P SQUARE
-  6x 3.5x13mm  
M SCREW
-  8x 6.3x13mm  
L1 GRUB SCREW
-  4x 5x16mm  
Z SHELF SUPPORT
-  4x 5x16mm  
Z1 SHELF GLASS SUPPORT

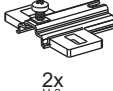

# STEP 2



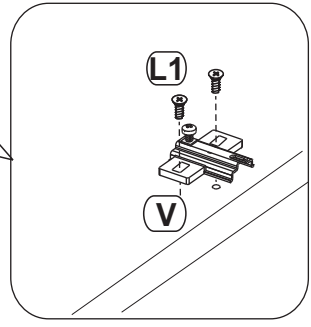
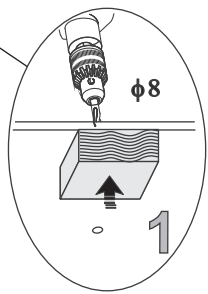
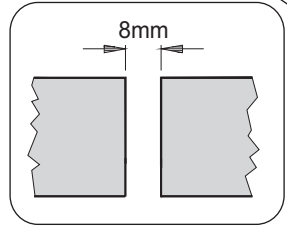
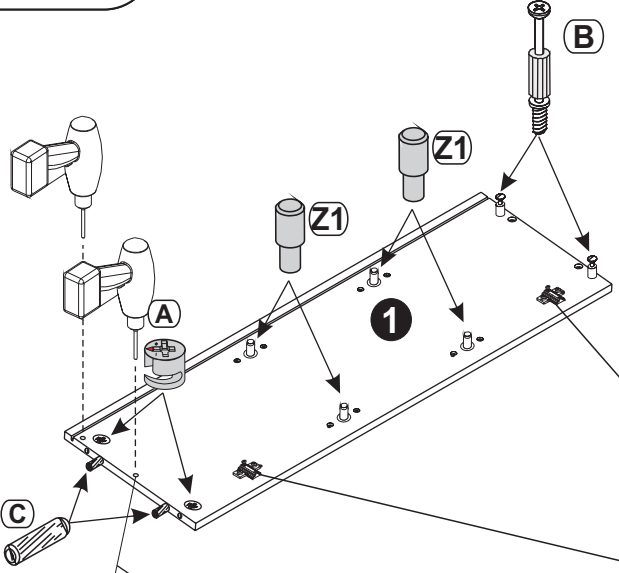
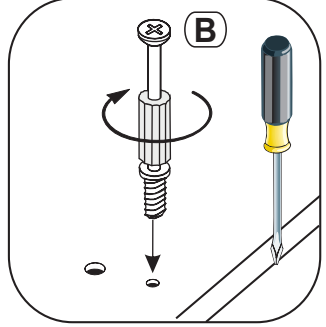
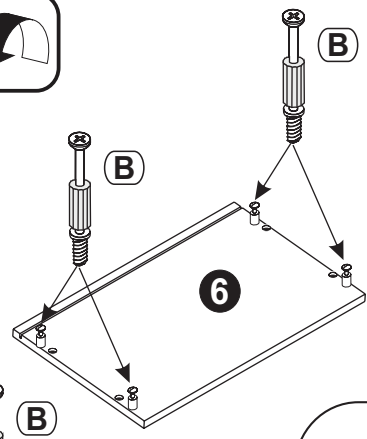
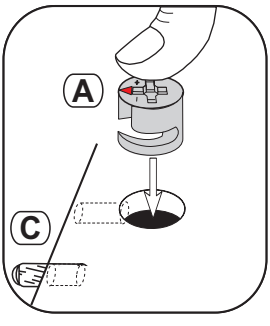
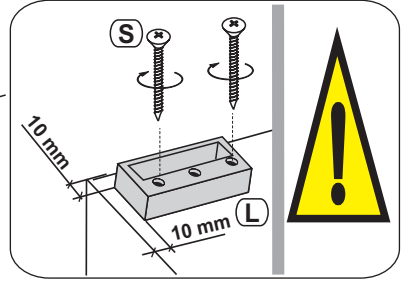
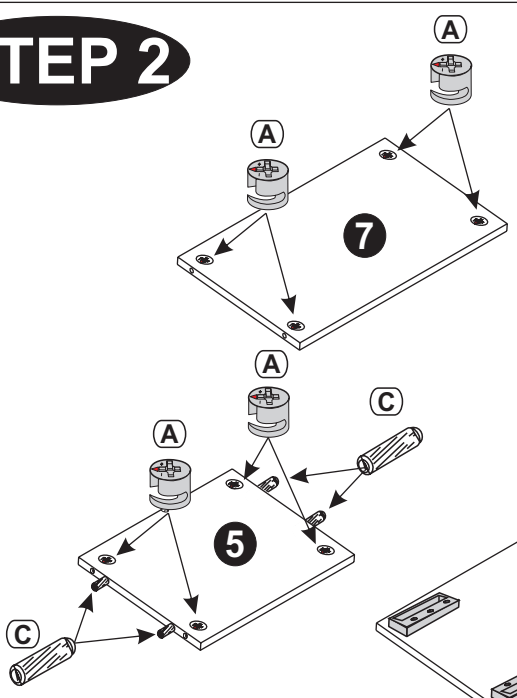

-  10x  
15x12mm  
**A**  
CAM LOCK
-  6x  
**B**  
CAM BOLT
-  6x  
8x28mm  
**C**  
DOWEL
-  4x  
**L**  
NYLON FOOT
-  4x  
6.3x13mm  
**L1**  
GRUB SCREW
-  8x  
4x40mm  
**S**  
SCREW
-  2x  
H-2  
**V**  
HINGE PLATE
-  4x  
5x16mm  
**Z1**  
SHELF GLASS  
SUPPORT





# STEP 3

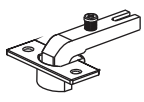
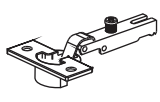

-   
 3x  
 3,5x30mm  
**F2**  
 SCREW
-   
 3x  
 4x16mm  
**F3**  
 SCREW
-   
 3x  
**I**  
 SLEEVE  
 GLASS
-   
 12x  
 3,5x13mm  
**M**  
 SCREW
-   
 2x  
**O**  
 HANDLE
-   
 4x  
**W**  
 HINGE
-   
 2x  
 K10  
**W1**  
 HINGE

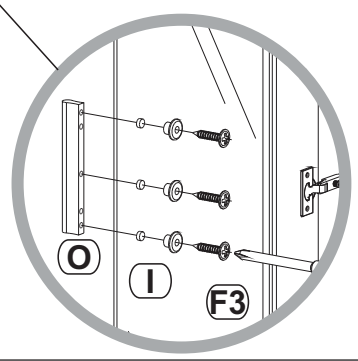
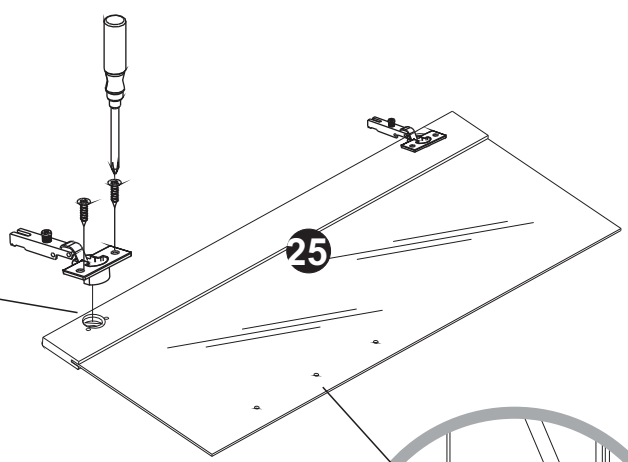
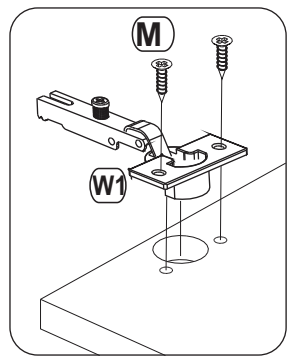
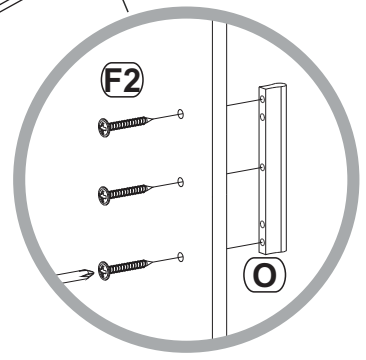
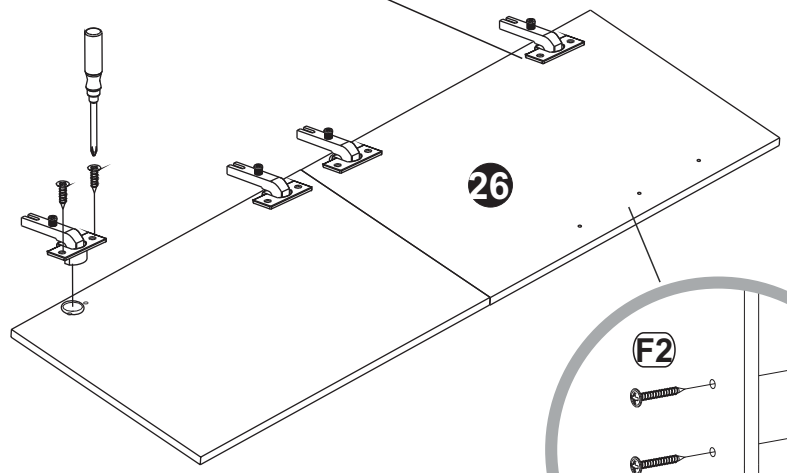
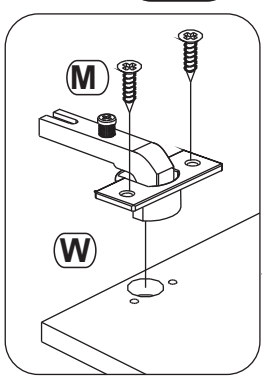

# STEP 4

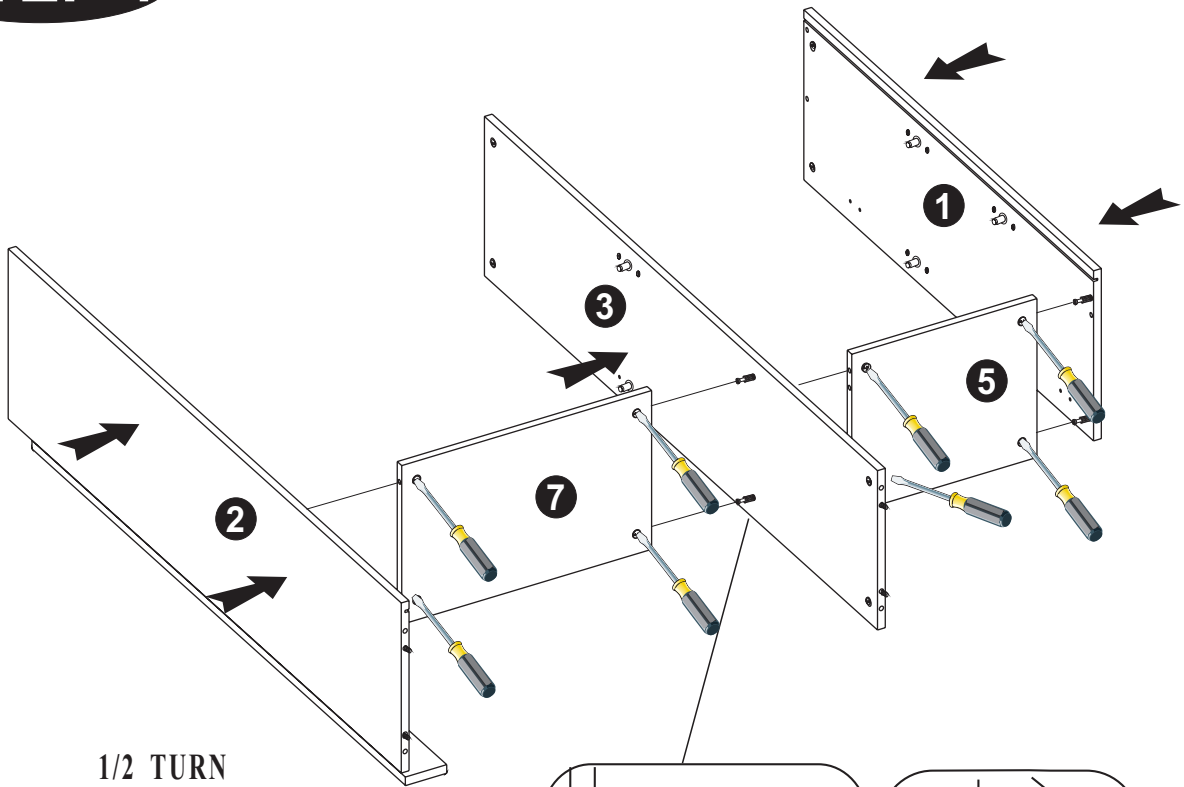

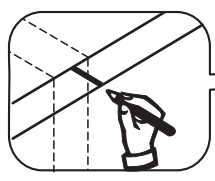
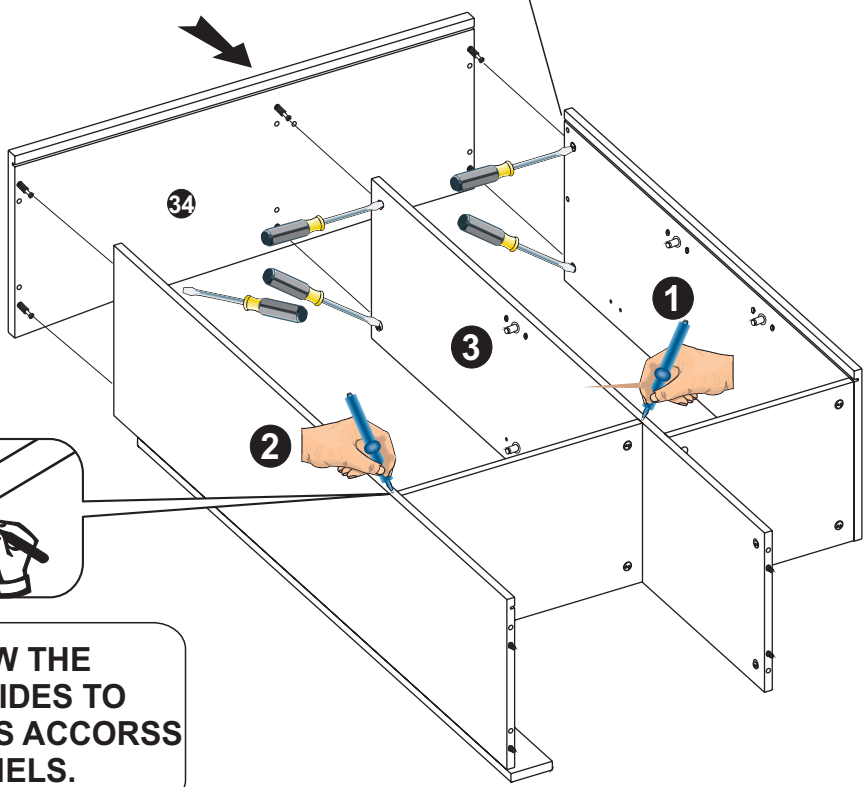
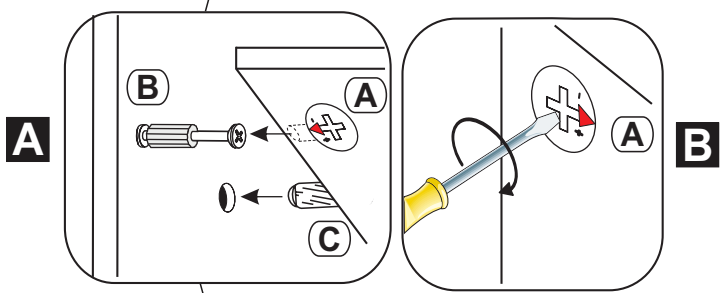
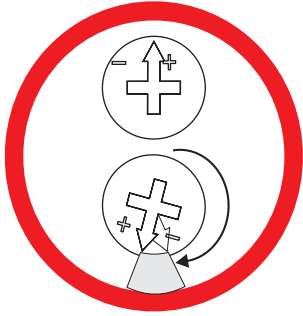

1/2 TURN  
CLOCKWISE.



PLEASE FOLLOW THE  
MARK ON THE SIDES TO  
FIX THE SCREWS ACCROSS  
THE BACK PANNELS.





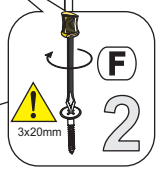
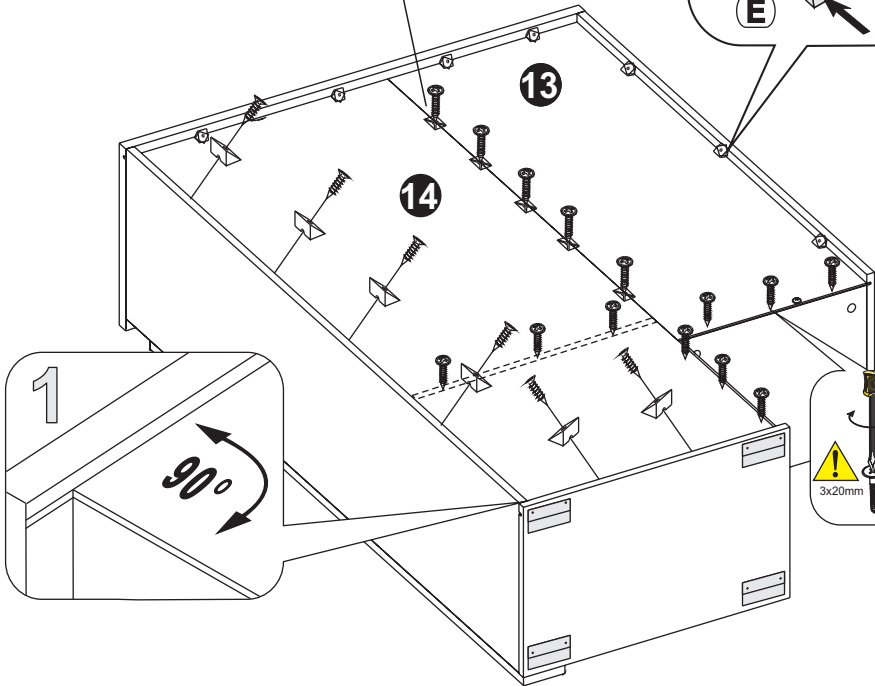
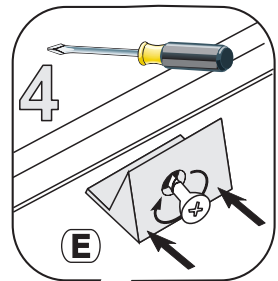
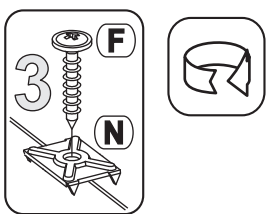
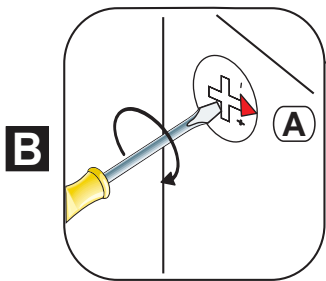
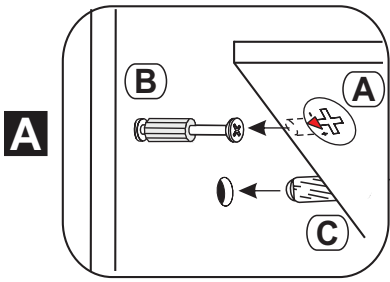
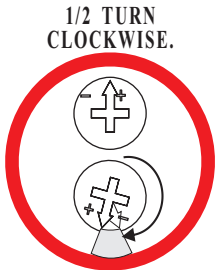
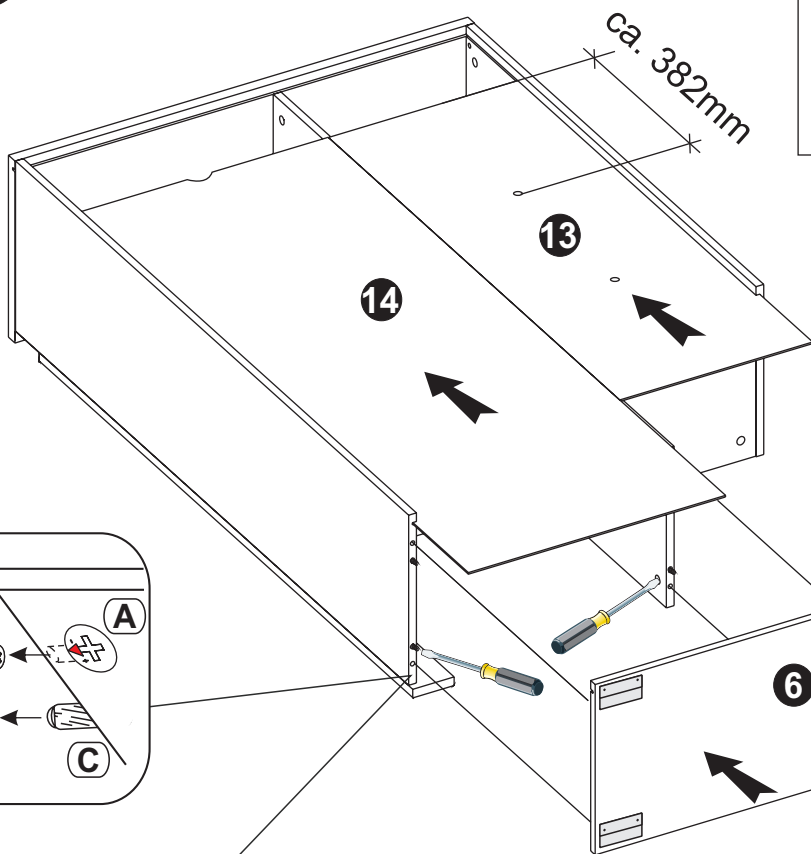

# STEP 5

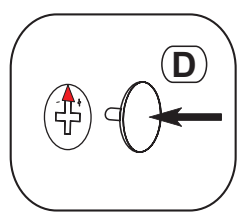
		
13x	14x 3x20mm	5x
E SECURING BRACKET	F SCREW	N METAL PLATE



# STEP 6



- |   |   |   |   |   |   |
|---|---|---|---|---|---|
|  |  |  |  |  |  |
| 22x   | 1x  | 2x  | 2x  | 8x<br>3,5x13mm  | 2x  |
| D<br>CAM COVER  | Q<br>METAL PLATE  | G<br>PEG BIG  | H<br>PEG  | M<br>SCREW  | X<br>LEVEL QUOIN  |

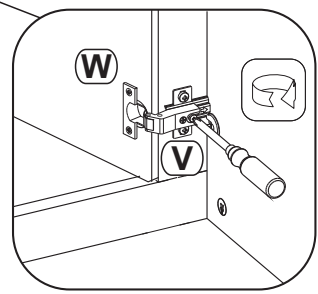
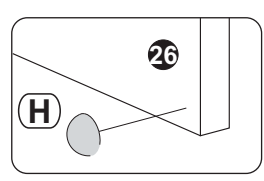
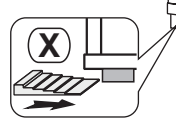
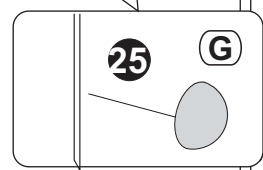
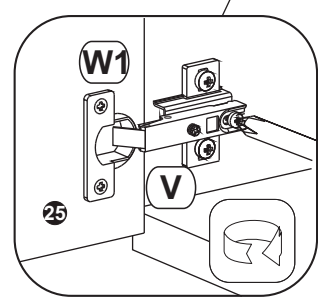
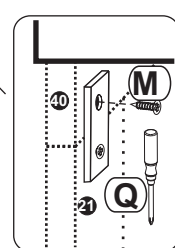
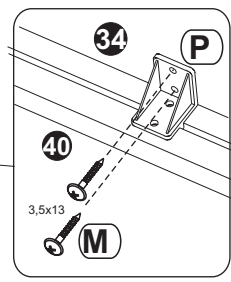
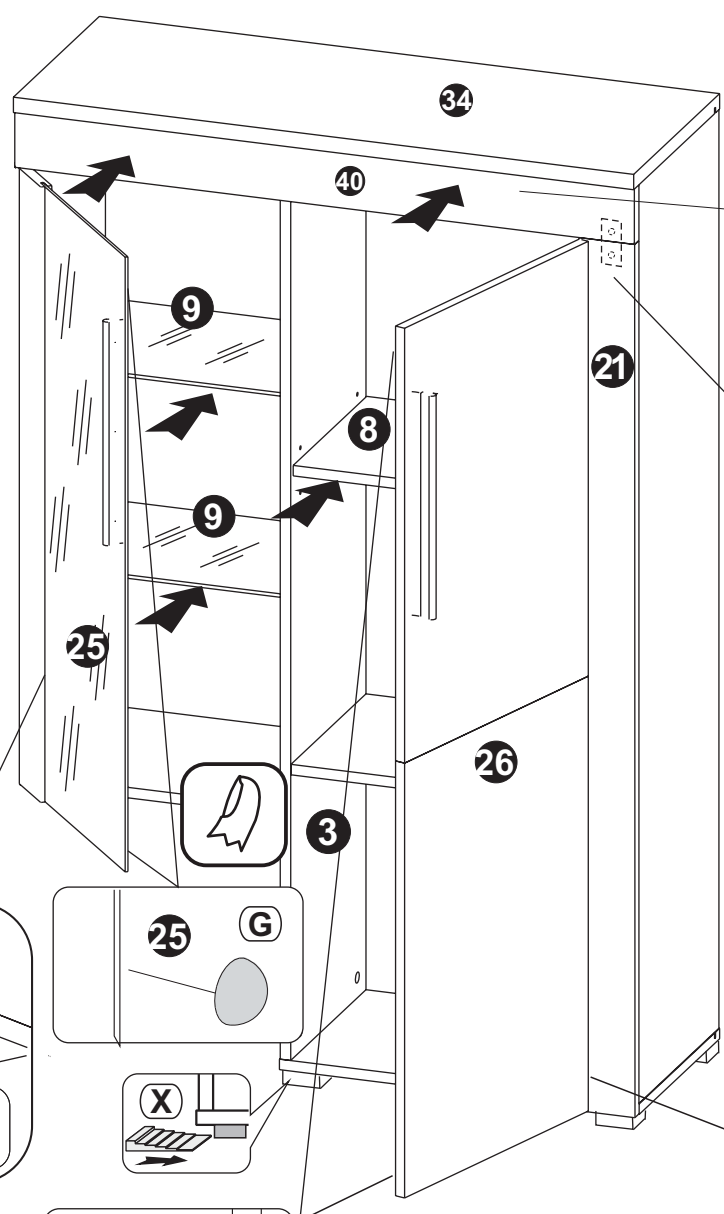

 LED Lights in type 317/319

# STEP 7

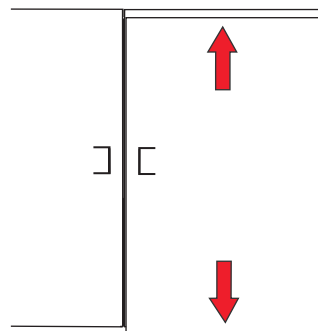
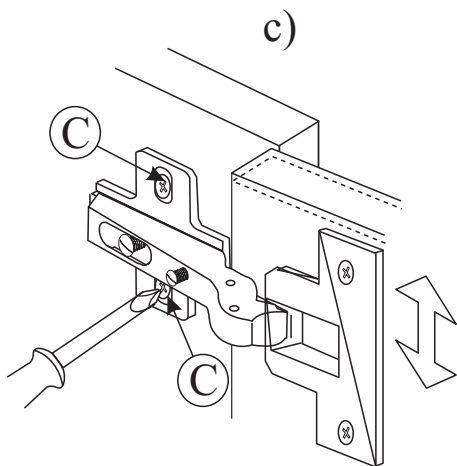
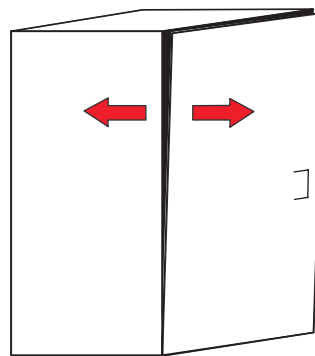
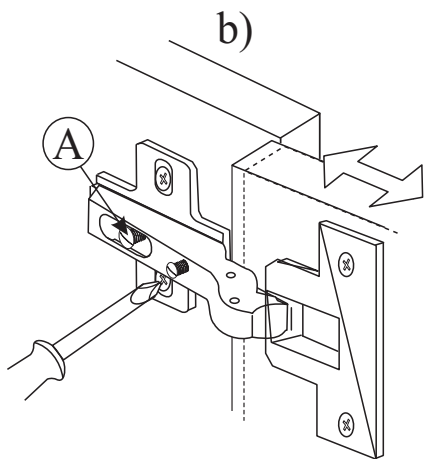
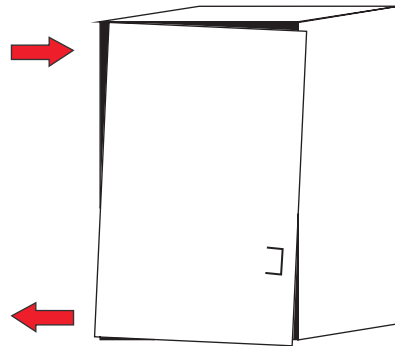
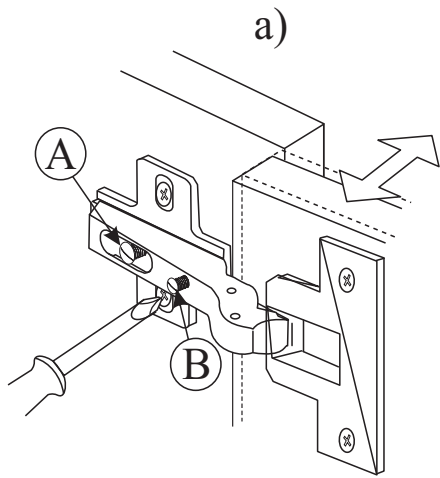

# STEP 8

