

Rhodes Coffee Table

Coffee Table Assembly



PLEASE READ this sheet prior to assembly to familiarise yourself with the various stages of construction. Carefully open the pack supplied and check the contents against the parts and fittings check list.

Do not destroy any of the packaging until you are certain that you have all the necessary parts for the assembly.

Please ensure that the packaging is disposed of in a safe environmentally friendly way .

CAUTION: There are small components used in the construction of this unit. These loose items should be kept away from young children whilst assembling your unit to avoid the danger of choking hazards.

MARBLE
HANDLE
WITH CARE

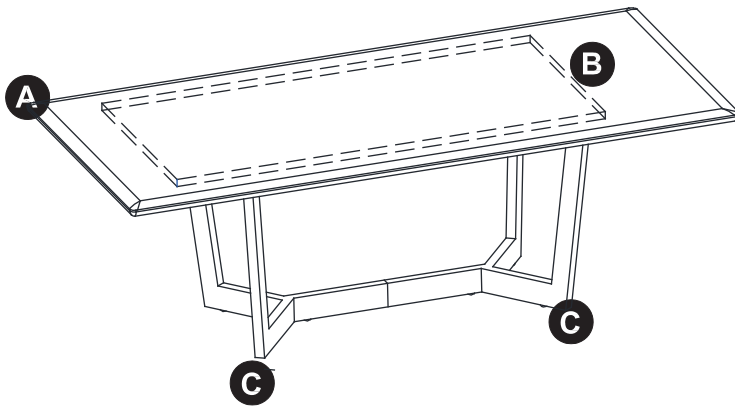

Please note that any marble product by its very nature requires it to be handled very carefully during the assembly process. Avoid any impact with other objects, twisting of the marble top or over tightening of the assembly bolts where they come in contact with the marble.

VISUAL IDENTIFICATION & FITTINGS

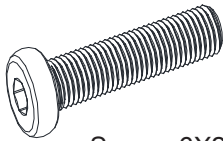

ITEM	DESCRIPTION	QTY
A	TABLE TOP	1
B	CONNECT PLATE	1
C	LEG	2

FITTINGS CHECKLIST

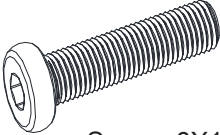
Code	Description	Qty	Code	Description	Qty	Code	Description	Qty
01	 Screw 6X25mm	x 4	02	 Plate Washer	x 4	03	 Allen key X3.9mm	x 1
04	 Screw 6X15mm	x 2						

CARE & MAINTENANCE

To maintain the appearance of your unit, regular dusting with a soft cloth will be adequate. For grime stains, wipe with a damp cloth.

HINTS & TIPS



Please retain your assembly instruction for future use.



This assembly requires two people

PRODUCT ASSEMBLY - Step by step guide

Step 1

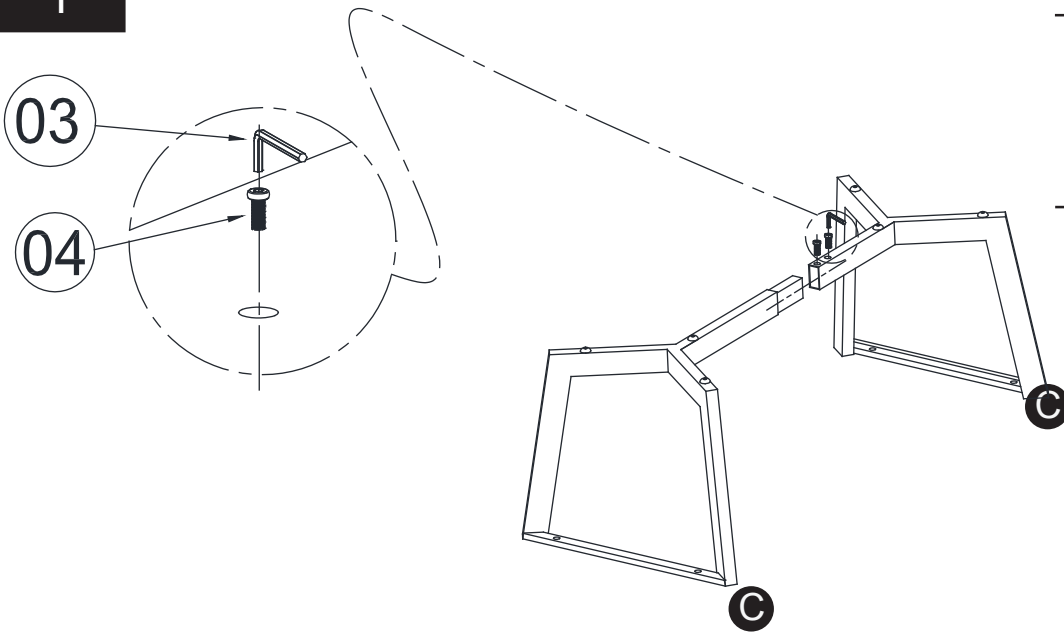

04 Screw 6X15mm x2

03 Allen key X3.9mm x1

Step 2

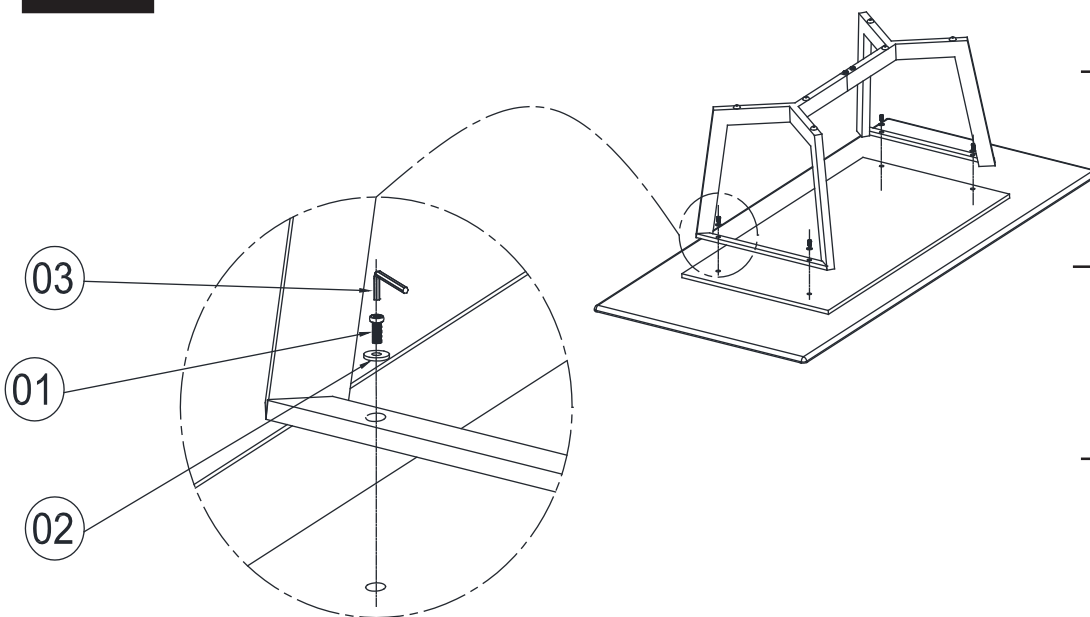

01 Screw 6X25mm x2

02 Plate Washer x4

03 Allen key X3.9mm x1

Step
3

Assembled

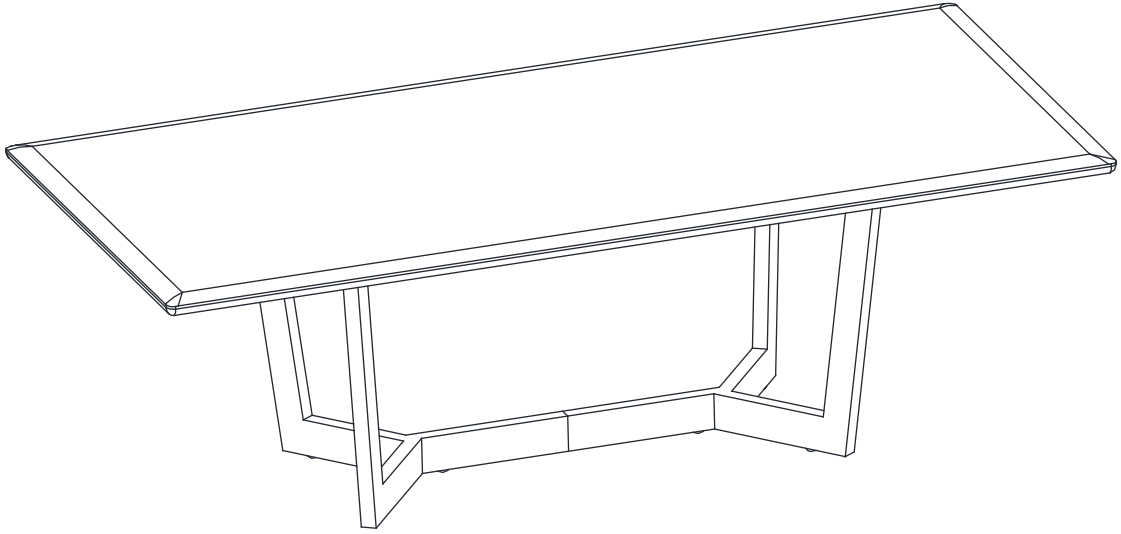

MARBLE

All marble ranges are treated with a durable lacquer that protects the surface of the stone. For daily cleaning, we recommend the use of a damp cloth. Spillages and moist substances should be removed immediately with a cloth to avoid marks on the surface. Aerosol silicon waxes and polishes should be avoided, as these may react with the lacquer.

Marble is susceptible to hard bumps and scratches on the surface and edges. We recommend that you use table mats under hot plates, mugs and glasses; and protective pads under ornaments will help prevent scratch.

Protection Instruction for Marble Table:

- 1. Do not strike the Marble using hard heavy objects.**
- 2. Do not put very hot things directly on the surface without using sufficient protection.**
- 3. Safety temperature is: -20 Degrees to +80 Degrees Centigrade.**
- 4. Ensure when moving the table, the top is removed first, and then the base put in position, then put the top back on top.**

DO NOT DRAG AND 2 PEOPLE TO LIFT TABLE AS IT IS VERY HEAVY.

Please be aware that all of our products are unique and hand finished. Because of this the final polishing process can in certain lights and angles show slight surface scratches which are polishing marks. These are not faults and are a normal characteristic of our product.

You may also notice an occasional small air bubble trapped in the lacquer. This is not detrimental to your product and is a normal byproduct of the finishing process.