







# ASSEMBLY INSTRUCTIONS

MODEL: B6582-Q-HB, B6582-Q-FBD, B6582-KQ-RAIL





Thank you for purchasing this quality product. Be sure to check all packing material carefully for small parts which may have come loose inside the carton during shipment. Identify and count all parts and compare with hardware list as below:

## STEP 1

(BOX 1) BOX OF HEAD BOARD			
ITEM	DRAWING	DESCRIPTION	QTY
A		HEAD BOARD	1

(BOX 2) BOX OF FOOT BOARD			
ITEM	DRAWING	DESCRIPTION	QTY
B		FOOT BOARD	1
C		FB LEG	2
D		LEG SUPPORT FOR FB	2
E		SLAT	11
F		CENTER SLAT	1
G		SLATS SUPPORT	6

(BOX 3) BOX OF SIDE RAILS			
ITEM	DRAWING	DESCRIPTION	QTY
H		SIDE RAIL (L&R)	2

(BOX 2) BOX OF FOOT BOARD (HARDWARE LIST)				
ITEM	DRAWING	DESCRIPTION	DIMENSION	QTY
I		C.S.K SCREW (M4)	4 X 32MM	6
J		JCBC (M6) WITH WASHER	6 x P1.0 x 35MM	3
K		JCBC (M6) WITH WASHER	6 x P1.0 x 100MM	2
L		ALLEN KEY M4	4 x 65MM	1
M		ALLEN KEY M5	5 x 65MM	1

Screw Driver is not included

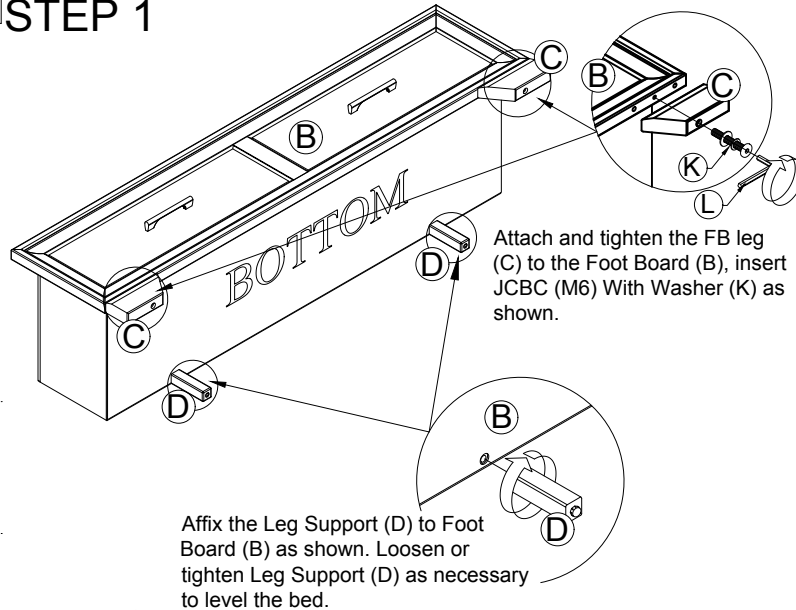
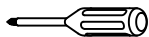

## STEP 2

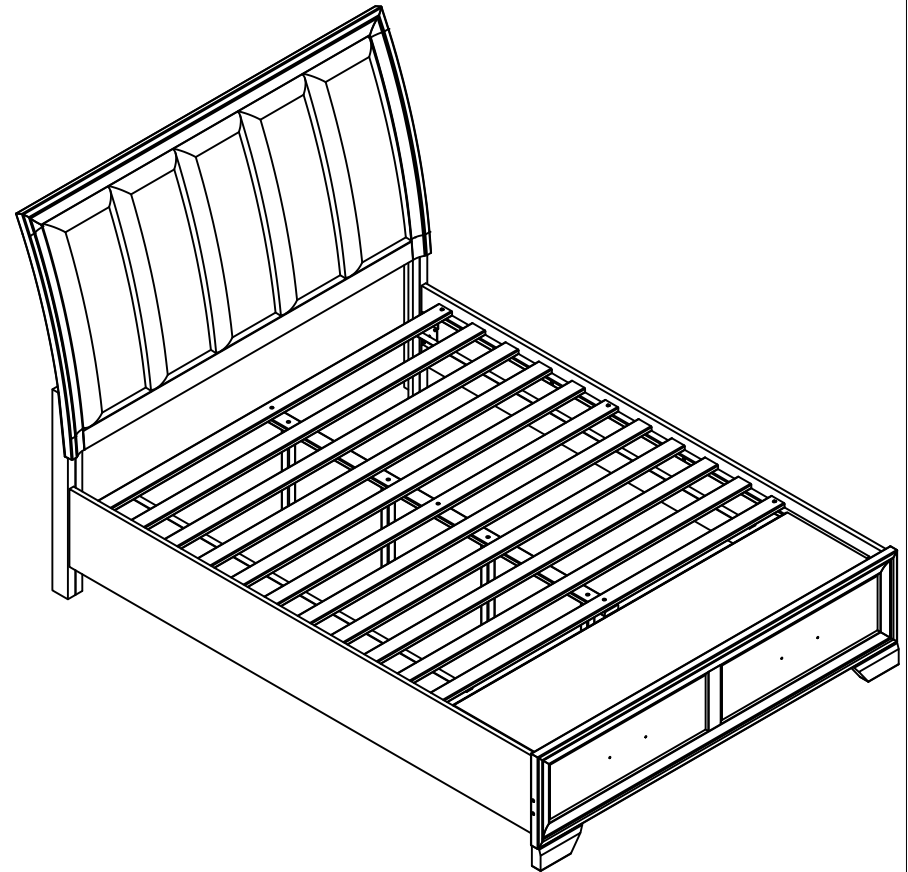
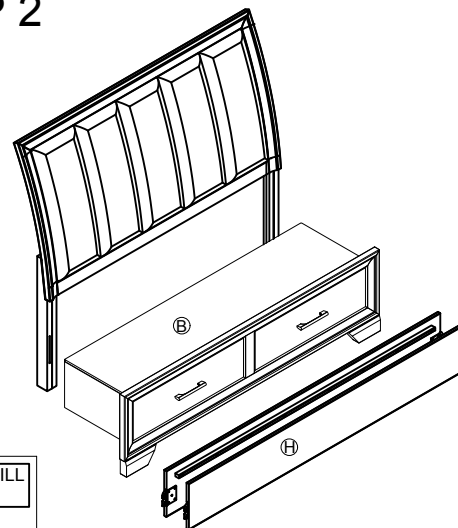

COMPLETED ASSEMBLY

NOTE: MUST TIGHTEN SCREW PERIODICALLY. WITH USE SCREWS WILL BECOME LOOSE CHECK THIGHT OF ALL SREWS EVERY 6-8 WEEKS.

### CLEANING INSTRUCTION

After assembled, clean & polish the complete parts if necessary with soft cloth and industrial recognized furniture polish.

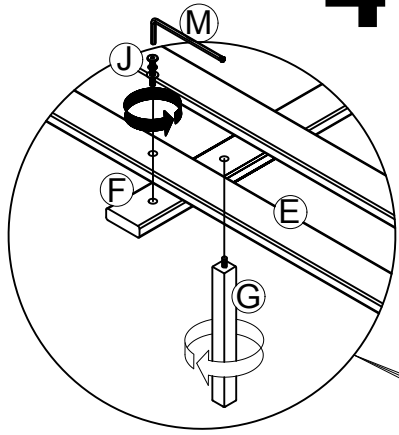

**4** STEP 4 :Spread out all the Slat (E) on the Center Slat (F). Further secure JCBC screw with washer (J) to middle pre-drilled slat to the Center Slat (F). Fix the Support Leg (G) into the Slat Support (F) as show and adjust it to the height required.

**5** STEP 5 :Finally, secure the Wooden Slat in place with the 32mm screws (I) with screw driver (\*not include)

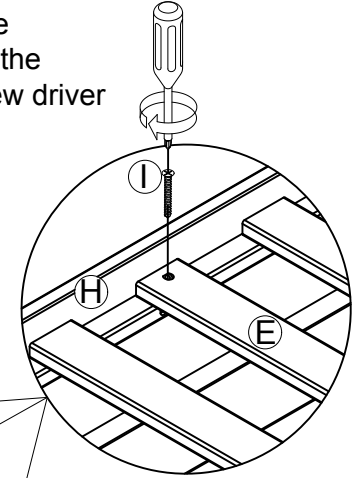

**3** STEP 3  
Fix both side rails to the Headboard and Footboard as below

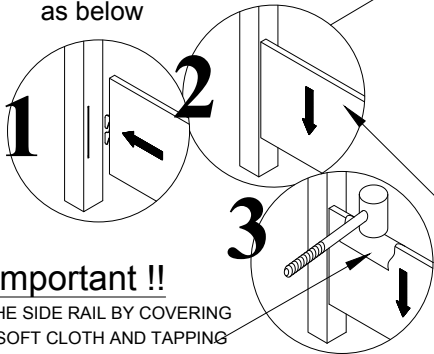

Press laterally into the groove and drop down.

**Important !!**

LEVEL THE SIDE RAIL BY COVERING WITH A SOFT CLOTH AND TAPPING WITH A HAMMER.

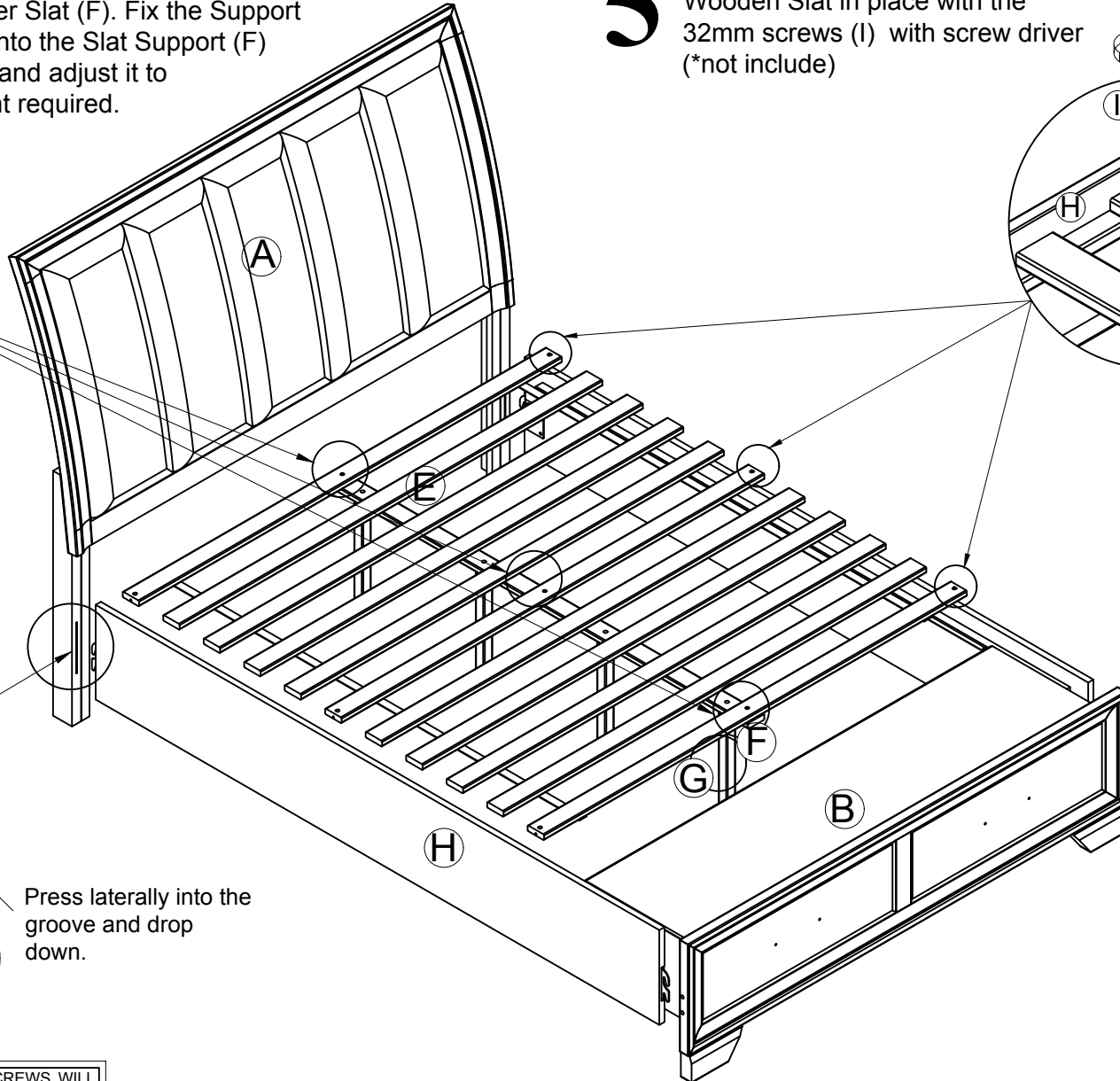

NOTE:MUST TIGHTEN SCREW PERIODICALLY.WITH USE SCREWS WILL BECOME LOOSE CHECK THIGHT OF ALL SREWS EVERY 6-8 WEEKS.

CLEANING INSTRUCTION

After assembled,clean & polish the complete parts if necessary with soft cloth ang industrial recognized furniture polish.